

## Datasheet

Subject to technical alteration  
Issue date: 08/11/2020



### » APPLICATION

Outdoor sensor measuring light, typically used in lighting applications to optimise energy efficiency through lighting control. The device is designed for outdoor areas, greenhouses, warehouses or industrial halls. The device has an integrated ambient light sensor with precise optical filtering adapted to the human eye. Tool-free opening, closing and wiring as well as removable cable entries ensure quick and easy installation.

### » TYPES AVAILABLE

Outdoor sensor light – active 0..10 V

LI65+

EXT-TN-1071511

### » SECURITY ADVICE – CAUTION



The installation and assembly of the device should only be performed by authorized personnel.

The product should only be used for the intended application. Unauthorized modifications are prohibited! The product must not be used in relation with any equipment that in case of a failure may threaten, directly or indirectly, human health or life or result in danger to human beings, animals or assets. Ensure all power is disconnected before installing. Do not connect to live/operating equipment.

Please comply with

- Local laws, health & safety regulations, technical standards and regulations
- Condition of the device at the time of installation, to ensure safe installation
- This data sheet and installation manual

### » NOTES ON DISPOSAL



As a component of a large-scale fixed installation, BELIMO Aircontrols Inc. products are intended to be used permanently as part of a building or a structure at a pre-defined and dedicated location, hence the Waste Electrical and Electronic Act (WEEE) is not applicable. However, most of the products may contain valuable materials that should be recycled and not disposed of as domestic waste. Please note the relevant regulations for local disposal.

**BELIMO Aircontrols Inc.**

## » TECHNICAL DATA

Measuring values	Brightness
Output voltage	1x 0..10 V or 0..5 V (adjustable via jumper), min. load 10 kΩ
Power supply	15..35 V DC or 19..29 V AC SELV
Power consumption	typ. 0,6 W (24 V DC)   1,5 VA (24 V AC)
Measuring range light	[0..20 fc / 0..200 Lux], [0..100 fc / 0..1000 Lux (factory default)], [0..200 fc / 0..2 kLux], [0..1000 fc / 0..10 kLux], [0..2000 fc / 0..20 kLux], [0..5000 fc / 0..50 kLux], selectable at the device
Accuracy light	±5% of measuring range
Sensor	Ambient light sensor with precise optical filtering appropriate to the human eye
Enclosure	enclosure USE-M, PC, pure white, cover PC, translucent
Protection	NEMA 4 (IP65 according to EN 60529)
Cable entry	M20 flexible, for wire max. Ø=0.18..0.35 in., removable
Connection electrical	removable plug-in terminal, max. 16 AWG
Ambient condition	-22..+158 °F (-30..+70 °C), max. 85% rH short term condensation

## » PRODUCT TESTING AND CERTIFICATION



### Declaration of conformity

The declaration of conformity of the products can be found on our website [https://www.belimo.us/en\\_US/](https://www.belimo.us/en_US/).

## » CONNECTION PLAN

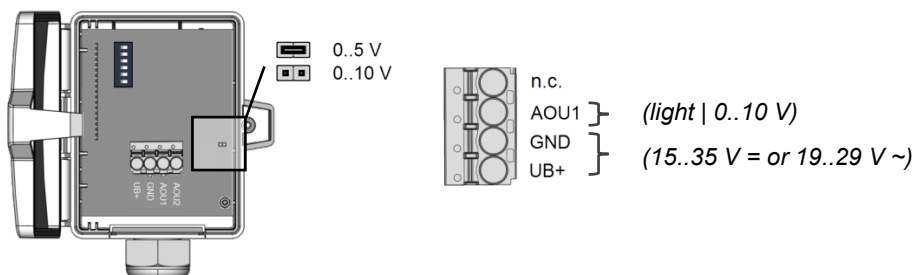

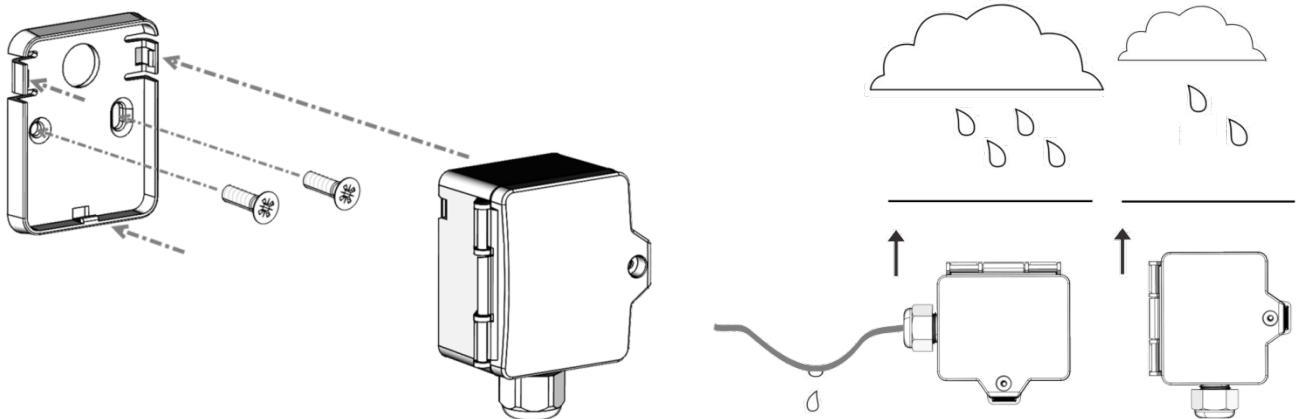

## » MOUNTING ADVICES

In case of outdoor installation avoid direct rain and sun contact. Probably use sun respectively rain protection. Cable entry from bottom or side. For side cable routing set loop so that precipitation can drain defined. Observe permissible ambient condition.

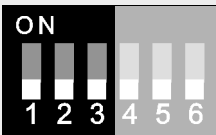
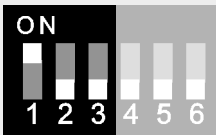
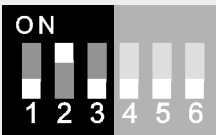
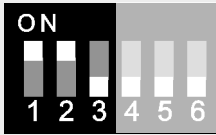
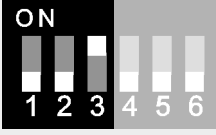

**BELIMO Aircontrols Inc.**

» **DIP SWITCH CONFIGURATION**

Measuring range light - DIP 1..3	
 <p><b>#0 (factory default)</b> SI = 0..1 kLux IMP = 0..100 fc</p>	 <p><b>#1</b> SI = 0..,2 kLux IMP = 0..20 fc</p>
 <p><b>#2</b> SI = 0..2 kLux IMP = 0..200 fc</p>	 <p><b>#3</b> SI = 0..10 kLux IMP = 0..1000 fc</p>
 <p><b>#4</b> SI = 0..20 kLux IMP = 0..2000 fc</p>	 <p><b>#5</b> SI = 0..50 kLux IMP = 0..5000 fc</p>

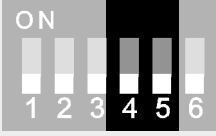
Measuring range temperature - DIP 4,5	
 <p><b>#0 (factory default)</b> reserved</p>	

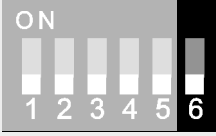
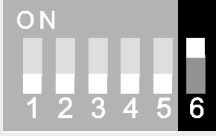
System of units - DIP 6	
 <p><b>#0 (factory default)</b> SI</p>	 <p><b>#32</b> IMP</p>

## » DIMENSIONS (IN.)

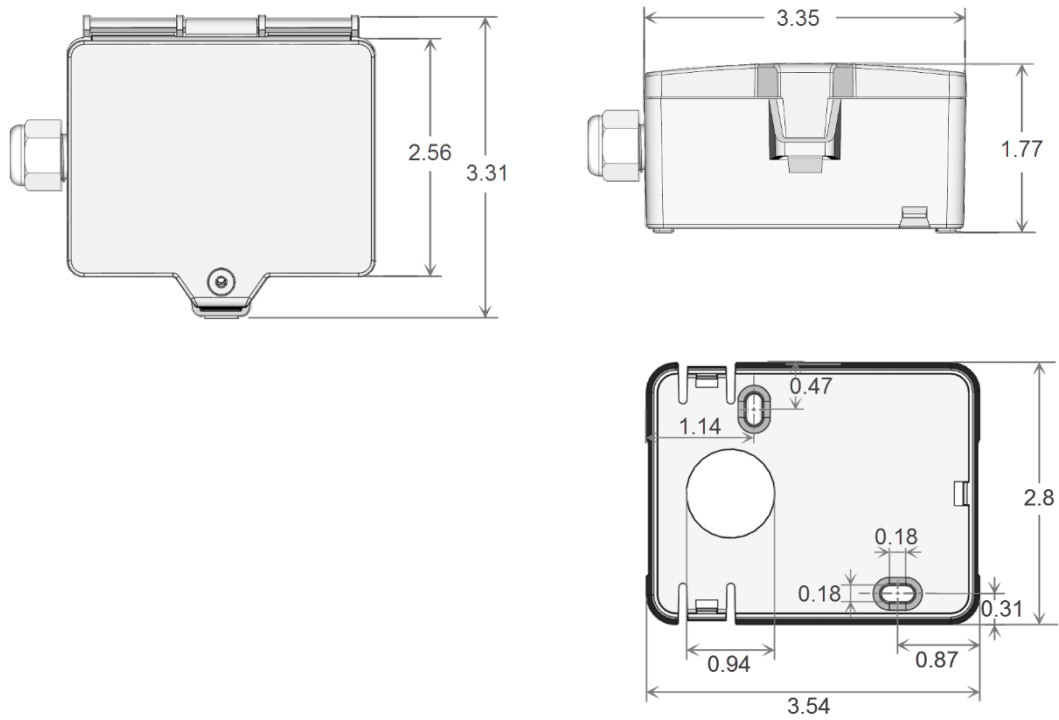

## » ACCESSORIES (INCLUDED IN DELIVERY)

Mounting base

Adapter M16 to 1/2" NPT (conduit adaptor)

Mounting kit universal

• Cover screw + screw cover • 2 Rawlplugs • 2 Screws (countersunk head) • 2 Screws (rounded head)

**BELIMO Aircontrols Inc.**