

APPLICATION CONDITIONS	MIN.	NOM.	MAX.
TEMPERATURE (°F)			
PRESSURE (PSI)			
SPEED (SFPS)			
STROKE LENGTH (IN)			
CYCLE RATE (CYL/SEC)			
MEDIA			

BILL OF MATERIALS				
ITEM	QTY	PART#	MATERIAL	DESCRIPTION

REVISIONS				
ZONE	REV.	DESCRIPTION	DATE	ECN #

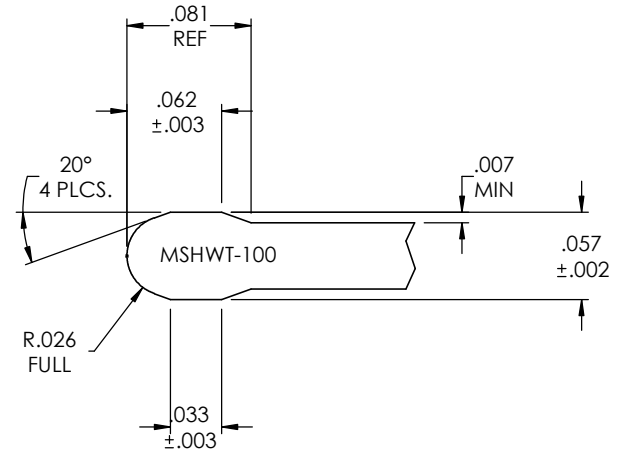
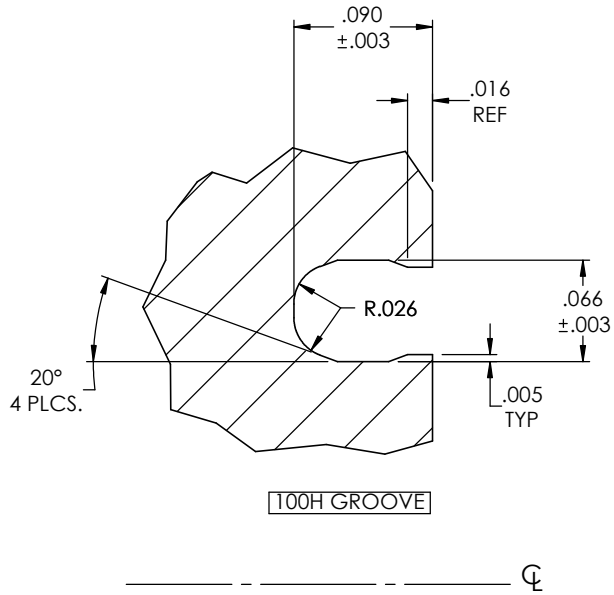

UNLESS OTHERWISE SPECIFIED:  DIMENSIONS ARE IN INCHES TOLERANCES: FRACTIONAL ± 1/16" ANGULAR: ± .5° TWO PLACE DECIMAL ±.01 THREE PLACE DECIMAL ±.005	NAME	DATE	 <b>MAUDLIN PRODUCTS</b> MW Industries, Inc.	
	DRAWN	L. DOUGLAS		12/6/17
	MFG REVIEW			
	ENG APPR.			12/6/17
JACKET MATERIAL:	COMMENTS:		TITLE:	
SPRING TYPE: 100 HELICAL			GENERAL ARRANGEMENT 100 HELICAL SPRING GROOVE AND TOOL	
O-RING:			SIZE: <b>A</b>	
DO NOT SCALE DRAWING			DWG. NO. MSHWT-100	
			REV	
	SCALE: NTS		SHEET 1 OF 1	

**PROPRIETARY AND CONFIDENTIAL**  
 THE INFORMATION CONTAINED IN THIS DRAWING IS THE SOLE PROPERTY OF MW INDUSTRIES, INC. ANY REPRODUCTION IN PART OR AS A WHOLE WITHOUT THE WRITTEN PERMISSION OF MW INDUSTRIES, INC IS PROHIBITED.