



.....
SAFETY
.....

Your safety and the safety of others is very important.

- In order to help you make informed decisions about safety, we have provided installation instructions and other information.
- These instructions alert you to potential hazards that could hurt you or others.
- Please do a job safety analysis before each task to identify potential hazards for your situation and remove/protect against them.
- You must use your own good judgment, and take your time.

Read and understand all safety precautions and instructions before installing this product.

**THIS PRODUCT IS FOR OFFROAD USE ONLY. ALL LIABILITY FOR
INSTALLATION AND USE RESTS WITH THE OWNER.**

**CARELESS INSTALLATION AND OPERATION CAN RESULT IN SERIOUS INJURY
OR EQUIPMENT DAMAGE.**

.....
Injury hazard
.....

Failure to observe these instructions could lead to severe injury or death.

- Always remove jewelry and wear eye protection.
- Always use extreme caution when jacking up a vehicle for work. Set emergency brake and use tire blocks. Locate and use the vehicle manufacturers designated lifting points. Use jack stands.
- Always use appropriate and adequate care in lifting components into place.
- Always ensure components will remain secure during installation and operation.
- Always wear safety glasses when installing this kit. A drilling operation will cause flying metal chips. Flying chips can cause serious eye injury.
- Always use extreme caution when drilling on a vehicle. Thoroughly inspect the area to be drilled (on both sides of material) prior to drilling, and relocate any objects that may be damaged.
- Always use extreme caution when cutting and trimming during fitting.
- Always tighten all nuts and bolts securely per installation instructions.
- Always route electrical cables carefully. Avoid moving parts, components that become hot and rough or sharp edges.
- Always insulate and protect all exposed wiring and electrical terminals.
- Always perform regular inspections and maintenance on mounts and related hardware.





Installation Instructions

Plate Front Bumper

Product Number: H3350, H3351, H3352

Application: 2015-2019 Chevrolet Colorado

Overview

Congratulations on your new purchase of the industries' best and most stylish front bumper available for the 2015 Chevrolet Colorado. This bumper has been designed to be lightweight and easily customized with the industry's highest quality accessories.

Your front bumper designed in 3-D from digitized data, CNC laser cut, fabricated, and powder coated... all in the U.S.A.

Enjoy the fit and finish of a quality 2015 Chevrolet Colorado Bumper from Fab Fours Inc.

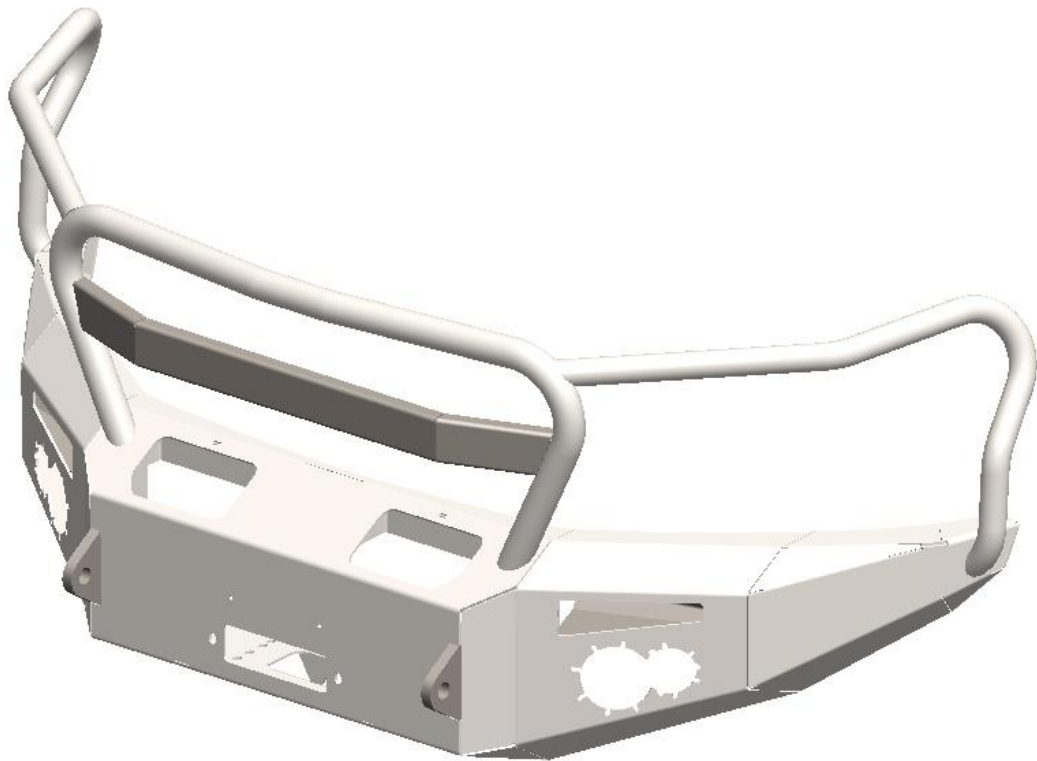



Installation Instructions

Plate Front Bumper

Product Number: H3350, H3351, H3352
Application: 2015-2019 Chevrolet Colorado

Parts List

- H335X replacement bumper
- 50046-HW fastener kit
- Instruction manual
- Plastic inserts QT (2) - 20090
- Turn signals QT (2) - 61738
- Fog lights QT (2) - 61737
- Resistors QT (2) - 61675
- Light hardware - HDLA-HW
- 20296 stud plates QT (2)
- Valence inserts – 20962/20963 – 20962-05/20963-05
- Fog light brackets – 20995/20996

Tools Required

- Socket wrench with extension (ratcheting wrenches may also be convenient)
- 7mm, 8mm, 9mm, 10mm, 15mm , and 5/8” sockets and box end wrenches
- 7/16”, 3/4” wrench and 7/16”, 3/4” ratchet wrench
- Electric Drill with 5/16” drill bit
- T15 torx
- Hex key sets
- Flat head screw drivers
- Floor jack and wood block.





Installation Instructions

Plate Front Bumper

Product Number: H3350, H3351, H3352
Application: 2015-2019 Chevrolet Colorado

I. Removal of OEM Bumper

Note: Save all OEM parts until installation is complete!

- A. Remove 6 torque screws from under the hood attaching the grille using a T15 torx.



Figure 1

- B. Remove 8 torque screws and 11 pop-pins from each fender well. Pry back the black plastic fender well.





Installation Instructions

Plate Front Bumper

Product Number: H3350, H3351, H3352
Application: 2015-2019 Chevrolet Colorado



Figure 2





Installation Instructions

Plate Front Bumper

Product Number: H3350, H3351, H3352

Application: 2015-2019 Chevrolet Colorado

- C. Using a 15mm socket or wrench remove 4 bolts attaching the skid plate to the bumper.

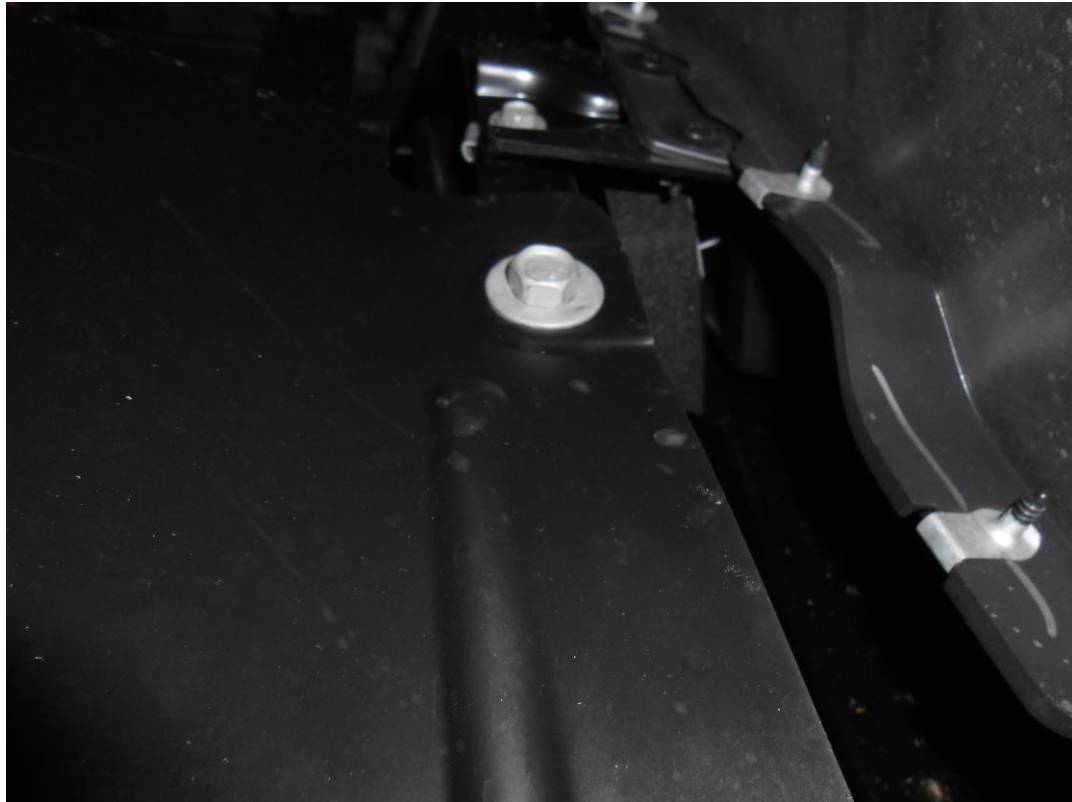

Figure 3

- D. Using a 10mm socket remove 2 bolts on the bottom of bumper.
E. Use a pin popper to remove 4 clips and 10 clips to detach the grille.
F. Using a 15mm socket remove 4 bolts holding the impact bar.
G. Remove the tow hooks with an 18mm socket or wrench.





Installation Instructions

Plate Front Bumper

Product Number: H3350, H3351, H3352

Application: 2015-2019 Chevrolet Colorado



Figure 4

II. Pre-Installation: Valence Installation

NOTE: The following installation steps apply to the installation of the front bumper. **PLEASE READ THE ENTIRE MANUAL BEFORE ATTEMPTING INSTALLATION.** Ignoring these steps will increase your probability of scratching the vehicle during product installation.

- A. Remove the bumper and valence pieces from the shipping carton. Lay all items out on a blanket to prevent damage to the powder coating.
- B. If you are installing aftermarket lights, do the wiring for those now. (But don't install or plug them in until after bumper is installed.)
- C. Using a marker and the provided hardware loosely bolt the valence mounting brackets to the valence (ref 5a). Position the valence on the truck and have another person hold it in place (ref 5b-c). At this point, reaching underneath the valence, adjust the valence mount so that it is flush against the plastic surface and mark the drill location on the plastic grill mount, indicated in figure 4c.





Installation Instructions

Plate Front Bumper

Product Number: H3350, H3351, H3352

Application: 2015-2019 Chevrolet Colorado

TAKE CARE TO MAKE SURE VALENCE AND VALENCE MOUNT ARE PROPERLY POSITIONED AS THIS WILL EFFECT FINAL FITMENT.

- D. Remove valence and drill hole with 5/16" drill in marked spot (ref 5c)**



Figure 5a (valence loosely bolted to valence mount)





Installation Instructions

Plate Front Bumper

Product Number: H3350, H3351, H3352
Application: 2015-2019 Chevrolet Colorado



Figure 5b (valence position relative to fender)



Figure 5c (valence position relative to grill)





Installation Instructions

Plate Front Bumper

Product Number: H3350, H3351, H3352
Application: 2015-2019 Chevrolet Colorado



Figure 5d (mount point on plastic grill mount)



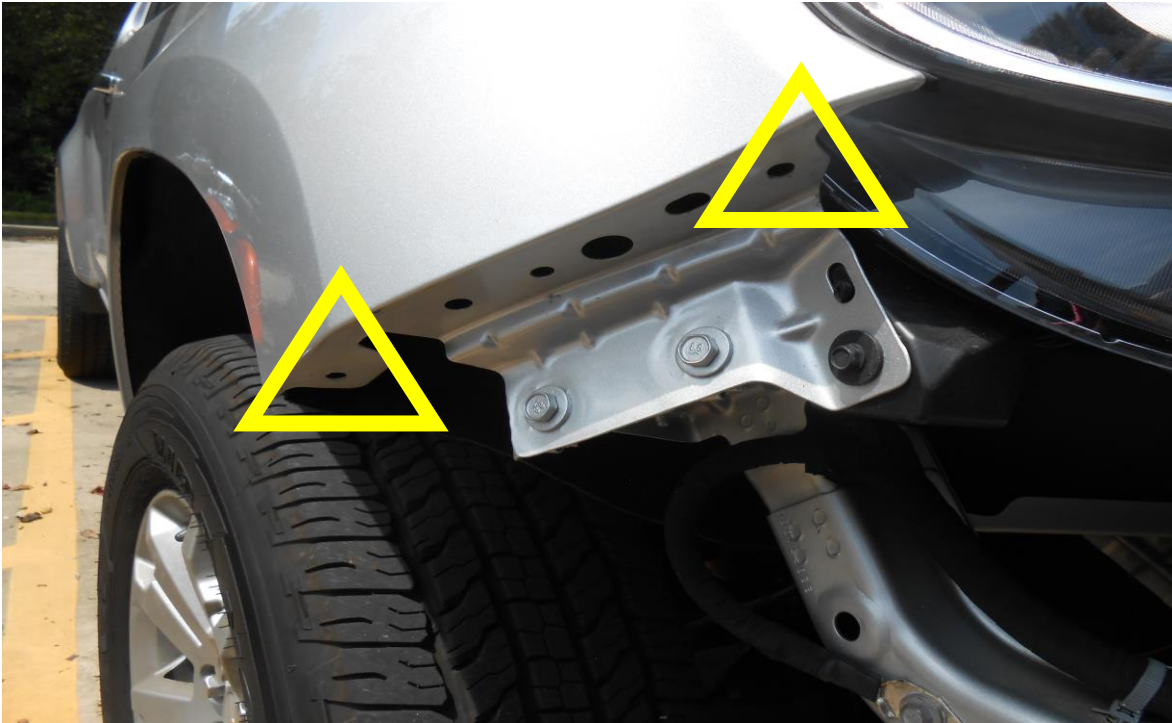

Figure 5e (mount points on fender)

- E. Pulling wheel well liner back, place valence in position (ref 5b), with another person holding valence in place, run bolts up through holes indicated by the triangles in Figure 5d. Hand tighten bolts.**
- F. Line up valence mount with previously drilled hole, insert bolt, and hand tighten (ref 6a-b).**
- G. Using a 7/16 wrench and ratchet wrench, tighten bolts running through the fender. Once valence is positioned properly at grill, tighten bolts running through valence mount (ref 6c).**



Installation Instructions

Plate Front Bumper

Product Number: H3350, H3351, H3352
Application: 2015-2019 Chevrolet Colorado



Figure 6a (wheel well liner pull back)





Figure 6b (bolts through mount points on fender)



Figure 6c (bolts through mount points on valence mount and plastic of grill)



Installation Instructions

Plate Front Bumper

Product Number: H3350, H3351, H3352
Application: 2015-2019 Chevrolet Colorado

III. Bumper Pre-Installation

- A. Remove the bumper from the shipping carton. Lay all items out on a non-scratch surface to prevent damage to the powder coating.
- B. Trace the wiring harness behind the headlight assembly and remove the turn signal light. On the back you should find four wires running from it to the harness. At this point follow the wiring diagram below. It is strongly recommended a multimeter or its equivalent is used to confirm wiring before splicing (Ref fig. 11a).
- C. Connect supplied wiring to tap connectors and run turn signal wiring out of the bottom. (Ref. Figure 10a) **DO NOT CONNECT WIRING TO BUMPER UNTIL FULLY INSTALLED.**

FAB FOURS TURN INDICATOR WIRING

WHITE WIRE = GROUND
BROWN WIRE = RUNNING
RED WIRE = TURN

FAB FOURS FOG LIGHT WIRING

WHITE WIRE = GROUND
BLACK WIRE = POWER

Note: For customers that are going from LED to our LED lights you should not need to use the provided resistors

For customers that are going from Halogen to our LED lights then you may need to use the provided resistors on our turn indicators; please wire the resistors between your power and ground wire

*Use a multi-meter or test light to determine the correct location for each wire





Installation Instructions

Plate Front Bumper

Product Number: H3350, H3351, H3352
Application: 2015-2019 Chevrolet Colorado

- D. Install turn indicators into the plastic light insert using three self-tapping screws as shown below.

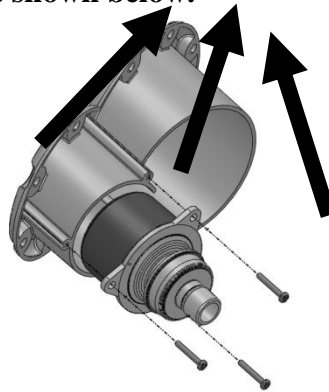

Figure 9a

- F. Install the light inserts with turn indicators into the cutout in the bumper. Use the $\frac{3}{4}$ " length $\frac{1}{4}$ " stainless steel button head, $\frac{1}{4}$ " washers and hex nuts to fasten the insert through the holes shown below.

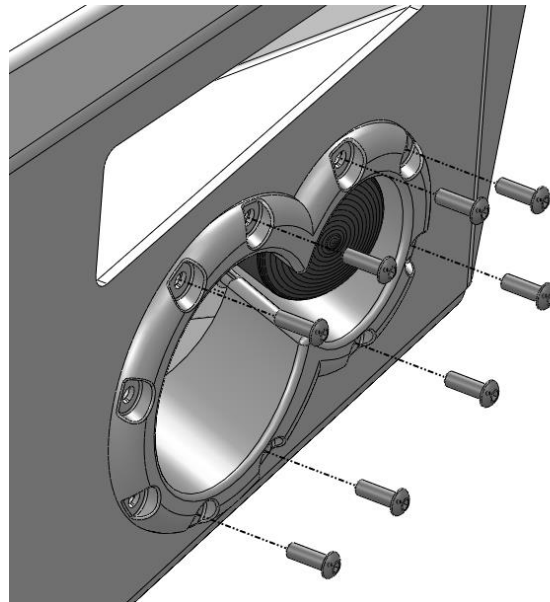

Figure 10a





Installation Instructions

Plate Front Bumper

Product Number: H3350, H3351, H3352
Application: 2015-2019 Chevrolet Colorado

G. Install the Fab Fours fog lights into the mounting brackets as shown below using the #8 button head screws, washers, and hex nuts.

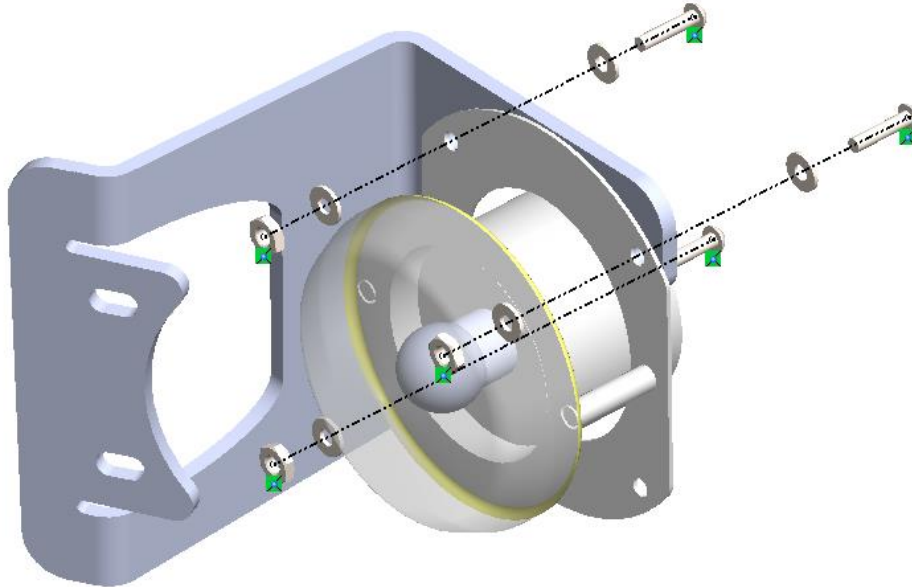

Figure 11a

H. Install the fog light and bracket into the bumper using the remaining two holes available in the light insert. Use the 1-1/2" length 1/4" stainless steel button heads with 1/4" washers and nuts.





Installation Instructions

Plate Front Bumper

Product Number: H3350, H3351, H3352

Application: 2015-2019 Chevrolet Colorado

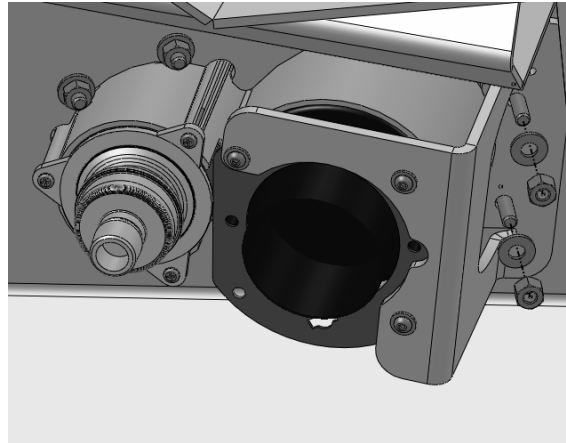

Figure 12a

I. Secure OEM electrical harness to the Fab Fours bumper.

J. Repeat steps A through I for other side.

Optional: If installing winch and roller fairlead into bumper, do so at this point.

Mount winch to bumper using two bolts to hold in it in place. Following steps A through C in front bumper installation, then remove bolts and slide winch left to right as necessary to install stud plates.

Follow the winch manufacturer's instructions for installation. If you are installing a winch with a pulling capacity of 12,000 lbs., the front face mounting holes must be used.

If not installing a winch, a license plate may be installed onto the front face of the bumper.

IV. Front Bumper Installation

- A. Use painter's tape to tape off the bottom of the grill on your truck to help prevent scratching the paint.**
- B. Using the OEM hardware and 15mm and 19mm ratchet wrenches, mount the brackets to your truck. There will be 12 OEM bolts, 4 on each side going to the front face, and 2 through bolts entering through**



the side of the frame (ref figure below)

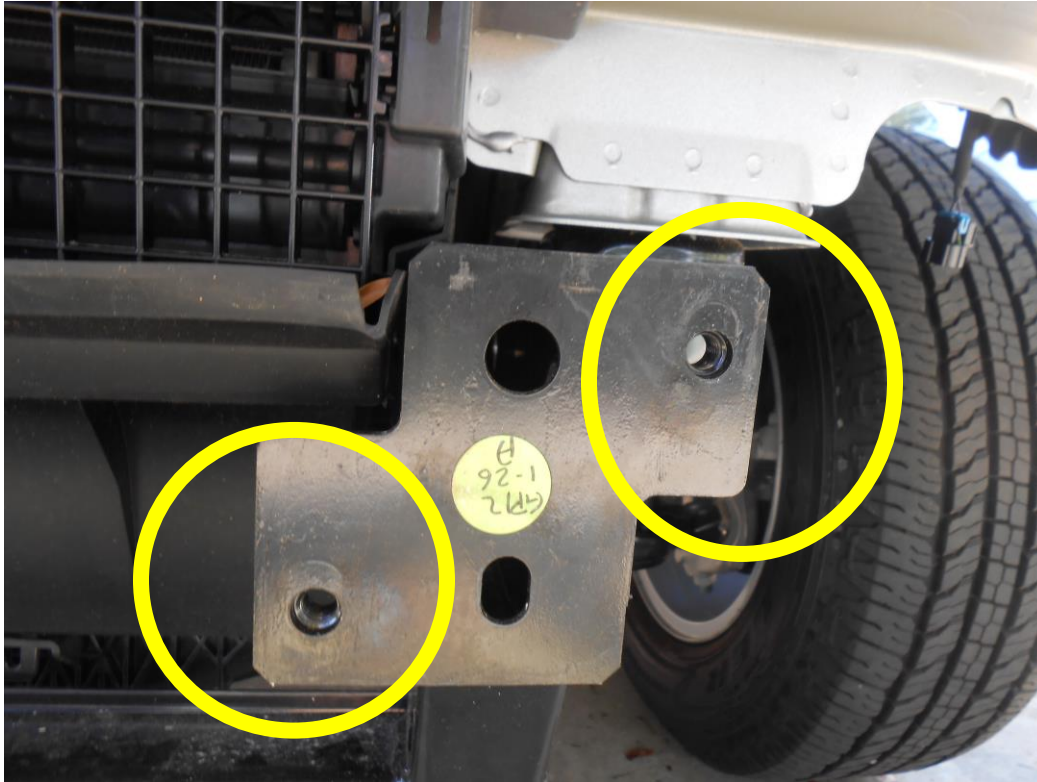

Figure 13a (frame mount plate)

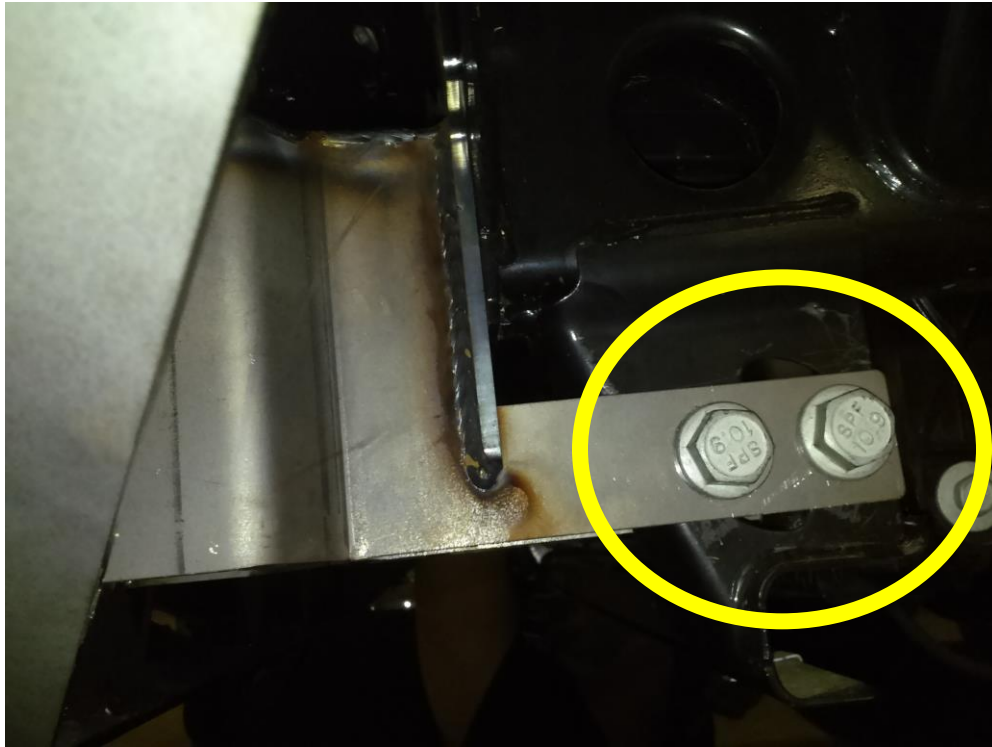

Figure 13b (bracket mounted to frame)

- C. Taking care to not hit the bottom of the grill. Mount bumper to bracket with the help of at least 2 others and a jack. Reaching in through the winch access holes insert the stud plates, indicated in the images below, through the front and hand tighten. Adjust the height of the bumper to the truck and tighten the bolts. (Fab Fours recommends $\frac{1}{4}$ " profile gap as a standard.)



Installation Instructions

Plate Front Bumper

Product Number: H3350, H3351, H3352
Application: 2015-2019 Chevrolet Colorado



Figure 13b (bracket mounted to frame)

D. Enjoy your new Plate Front Bumper from Fab Fours!





Installation Instructions

Plate Front Bumper

Product Number: H3350, H3351, H3352
Application: 2015-2019 Chevrolet Colorado

VII. Maintenance/Care

- Periodically check and tighten all fasteners.
- Stripped, fractured, or bent bolts or nuts need to be replaced.
- After washing of the vehicle make sure to fully dry all surfaces

VIII. Contact Information

Fab Fours Inc.
1312 Camp Creek Rd
Lancaster, SC 29720

Phone (866)-385-1905
Fax (866)-574-1424
Email Support@fabfours.com



More than expected... Better than expected

