

BUG BLOCKER™ BEHIND 2" TRACK HIGH LIFT

1)

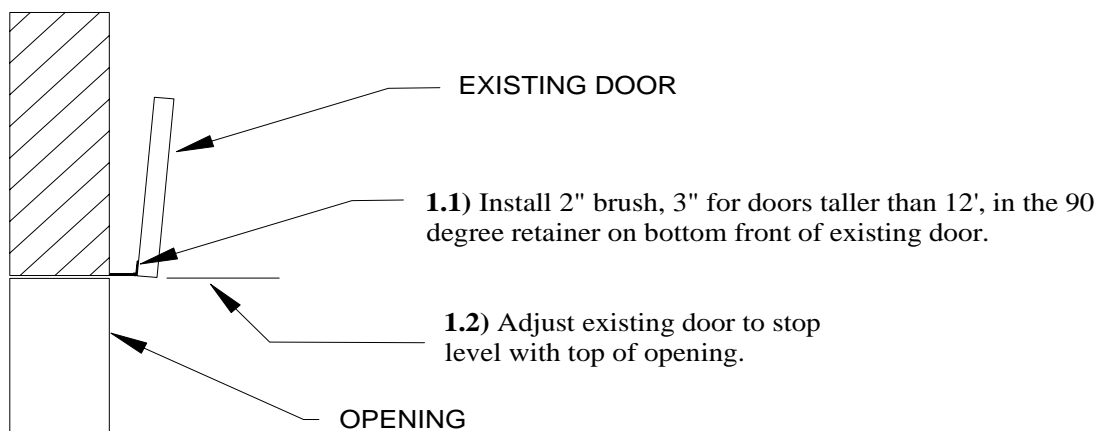

2)

CAUTION: IF EXISTING TRACK IS NOT WELL MOUNTED, EXTRA BRACING TO SIDE PLATE WILL BE NECESSARY

2.1) Bolt side angle with 1- $\frac{1}{2}$ " brush seal to the existing track using the existing track bolts and nuts.

45 DEGREE RETAINER WITH 1- $\frac{1}{2}$ " BRUSH SEAL

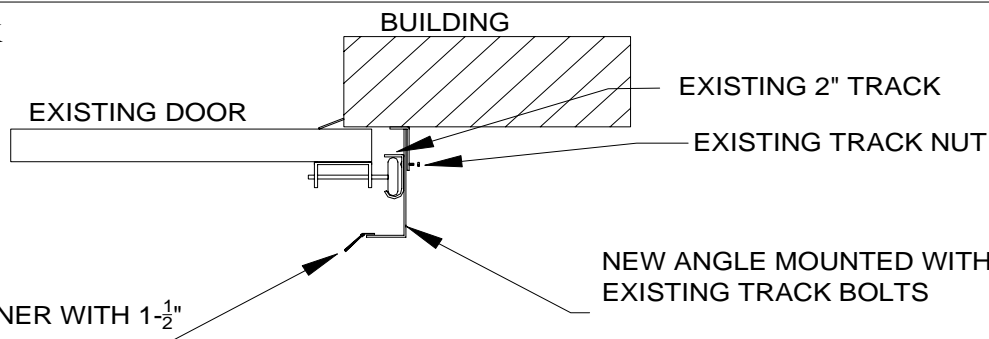

3)

3.1) Cut the bottom off new lower vertical track so that it is 2" shorter than existing track.

3.2) Install jamb brackets with bolts or weld to the new reverse angle. Start with the shorter brackets on the bottom and go longer as you work your way up. Space the jamb brackets evenly. The top jamb bracket will have 2 slots and must be mounted so that it will be $\frac{1}{2}$ way above the top end of the new vertical.

3.3) Install new 2" lower vertical to jamb brackets. Space 2 inches from angle at bottom end. Slope as indicated in table.

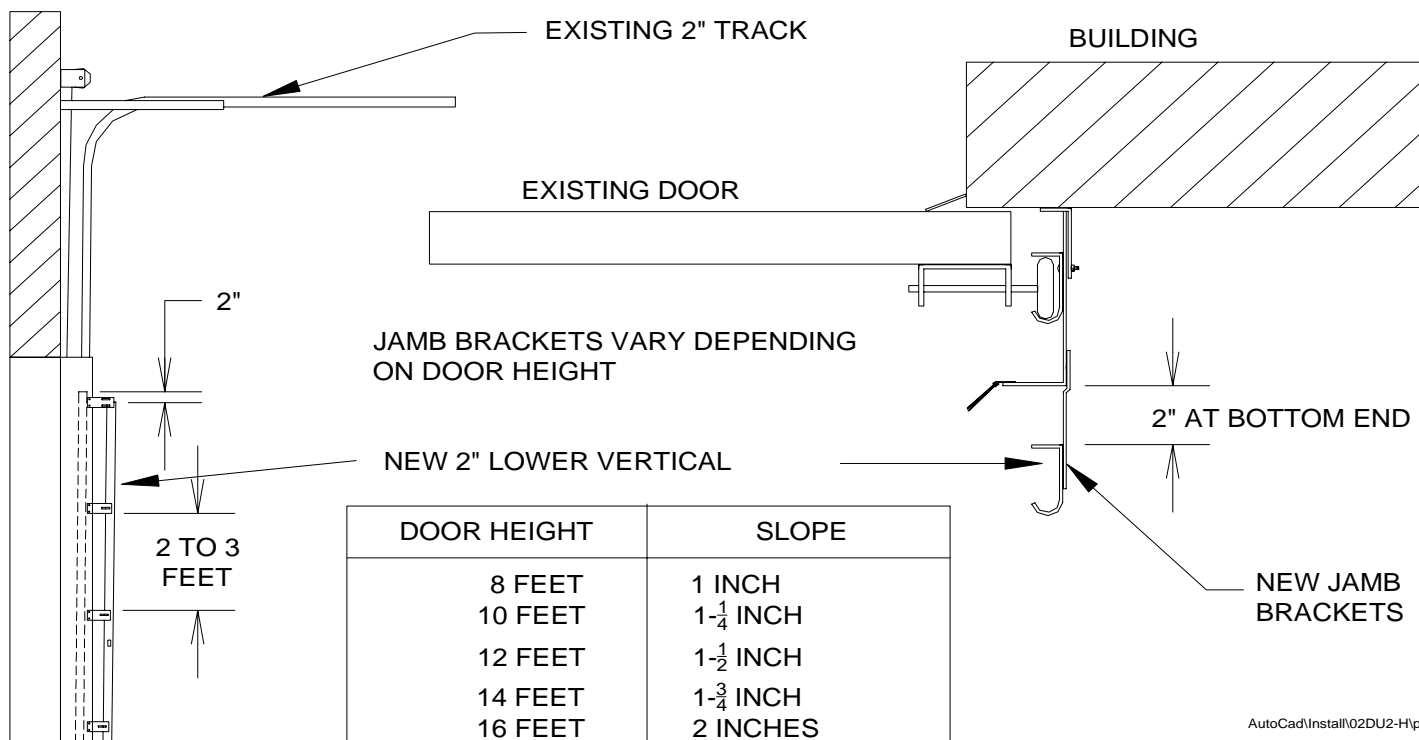

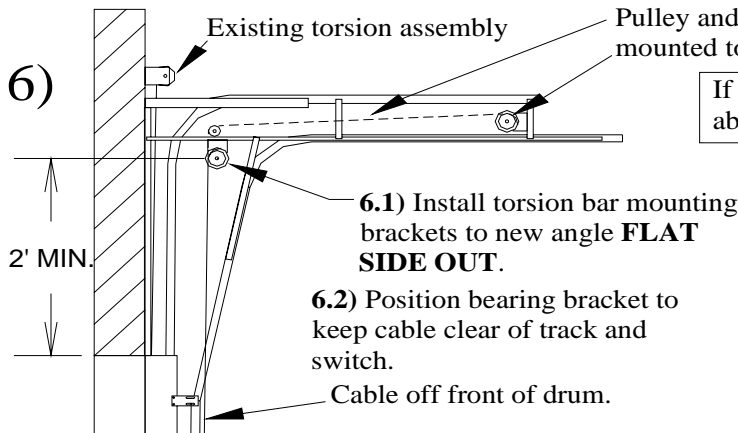
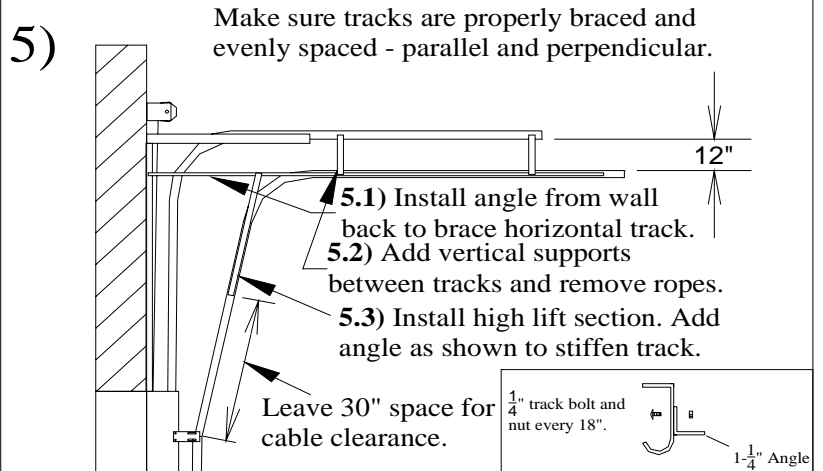
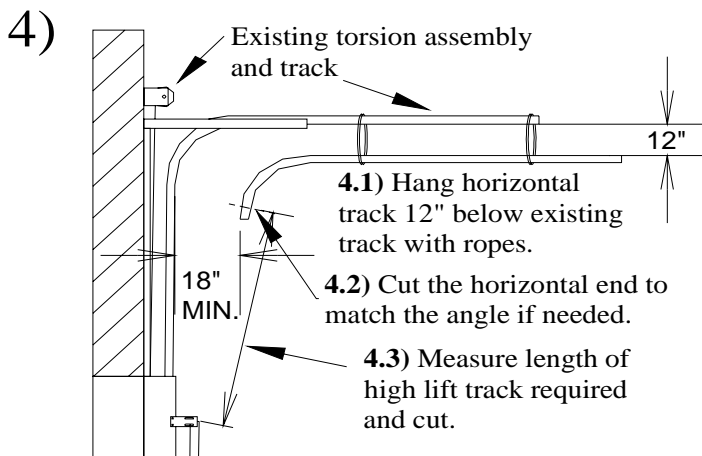

If the torsion bar can not be mounted 2 FT minimum above the opening, use a pulley and rear mount.

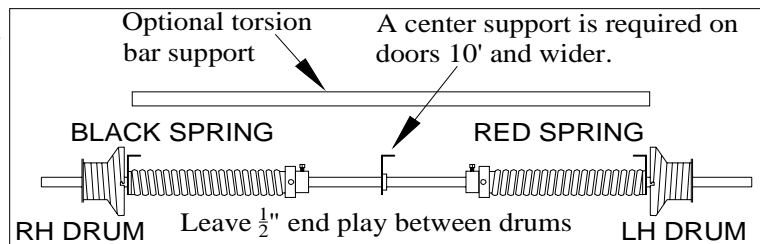

7.1) Install on the bottom section the right bottom bracket with 4ea Pk's and 2 track bolts. Install #1 center hinges and a #1 hinge on the right end **FINGER TIGHT**. (**INSTALL THE HINGES WITH THE NUMBERS DOWN**)

7.2) Install bottom section in the track and add the other bottom bracket and #1 hinge on the left end. (Use long stem rollers on bottom corners.)

7.3) Identify the top of an intermediate section. The top has only one finger and the bottom has 2 fingers.

7.4) Install intermediate section using #2 hinges on top ends and #1 hinges in center positions.

7.5) Install all hinges finger tight until all sections are in place and checked for proper engagement.

7.6) Install the rest of the sections using the next higher number hinge on each section.

7.7) Attach the top roller carriers so that rollers are at **TRACK SPLICE**. (At least 8" from top of door)

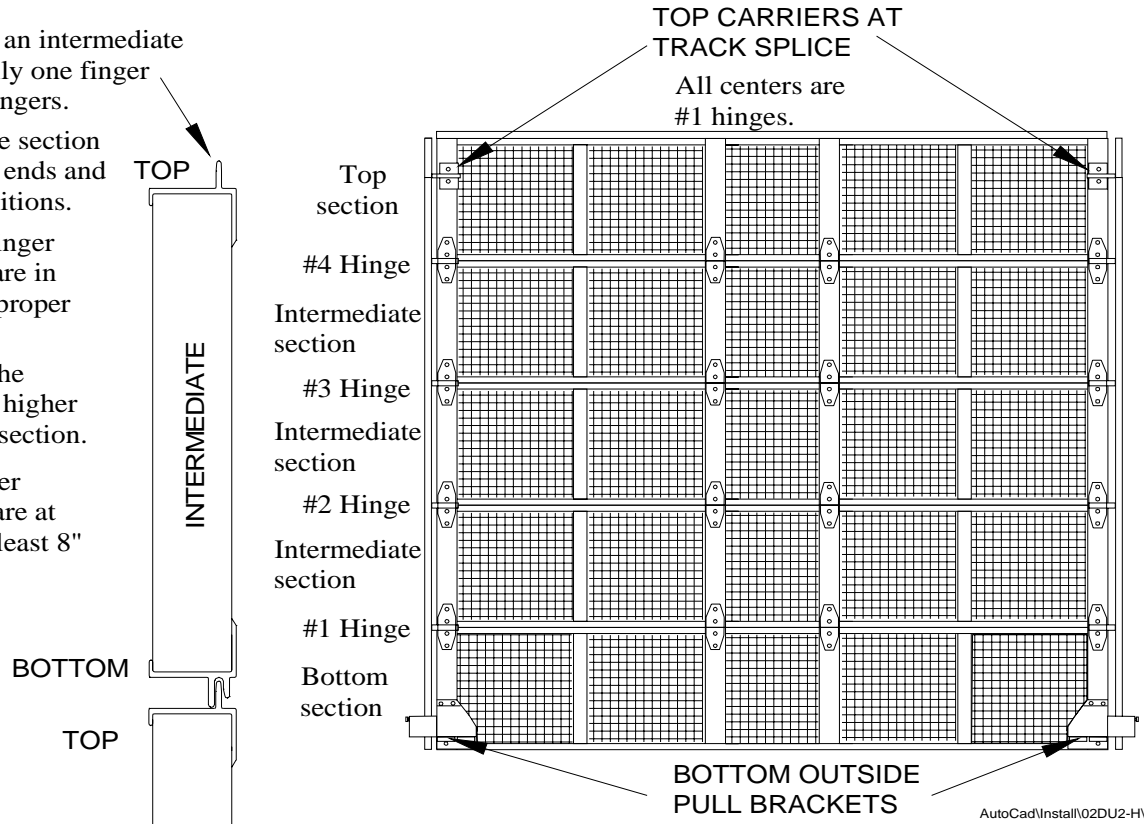

- 8) **8.1)** Measure the distance from the torsion shaft to the floor and calculate the cable length as follows:
(For a rear mounted torsion the distance is measured from the floor around the pulley to the torsion bar.)

DRUMS:

- OMI 54 HL-LD (5- $\frac{7}{8}$ " Dia.) Floor to shaft + 63" - cable lift.
 OMI 54 HL (7- $\frac{3}{16}$ " Dia.) Floor to shaft + 66" - cable lift.
 OMI 120 HL (9- $\frac{3}{16}$ " Dia.) Floor to shaft + 134" - cable lift.
 OMI 164 HL (11" Dia.) Floor to shaft + 181" - cable lift.

8.2) Carefully measure the cables and flatten stops into position.

8.3) Cut off excess cable.

8.4) Install cables and wind springs as specified on the front cover.

8.5) Install down lock and handle with PK's (self-drillers).

8.6) Install pull rope on bottom under right hand roller.

8.7) Tighten down all fasteners.

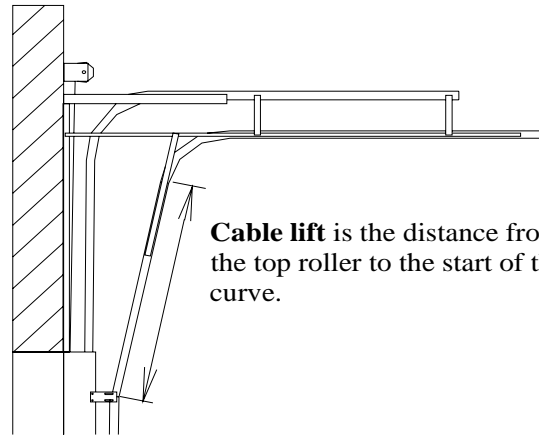

Cable lift is the distance from the top roller to the start of the curve.

9)

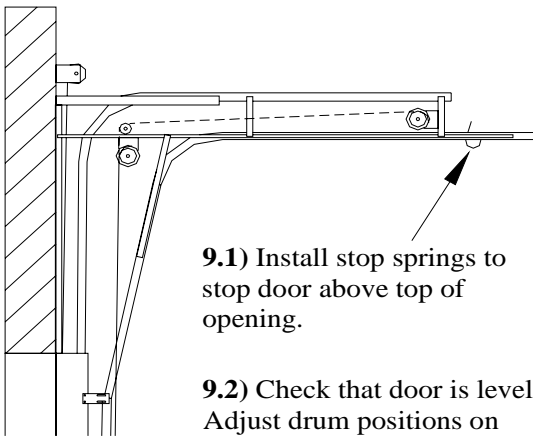

9.1) Install stop springs to stop door above top of opening.

9.2) Check that door is level. Adjust drum positions on shaft if necessary.

10)

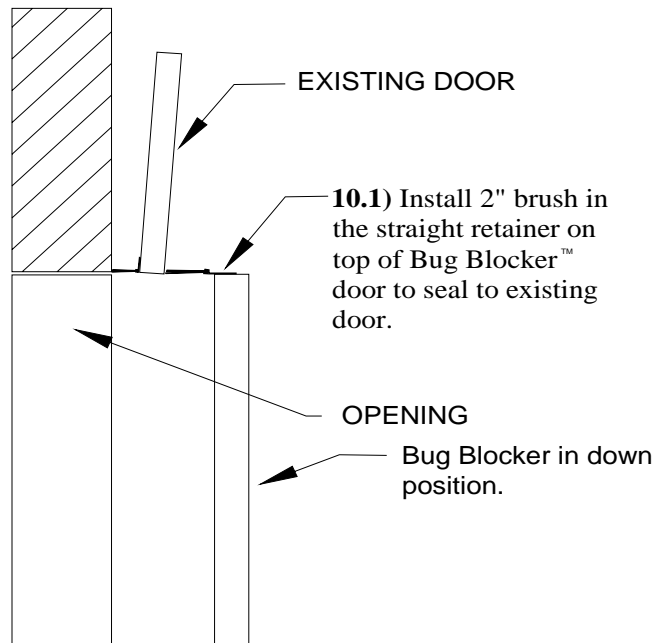

10.1) Install 2" brush in the straight retainer on top of Bug Blocker™ door to seal to existing door.

OPENING

Bug Blocker in down position.