



green  
GLUING

## ROBAPUR 20 MOD

Adhesive Melters  
Efficient | Melt-on-Demand | Safe

## DEMAND-ORIENTED MELTING FOR INCREASED EFFICIENCY

The RobaPUR 20 MOD melter is suitable for melting and delivering of reactive PUR adhesives in 20 kg containers. The gentle and consumption-dependent melting protects the adhesive properties even after extended interruptions. A premelter variant is also available for filling adhesive pots.

### Gentle and Demand-oriented

The press cylinder is a closed, airtight area. As PUR reacts to moisture, the press cylinder is additionally equipped with dry gas application. The melting grill is heated separately from the adhesive reservoir. Once there is enough melted adhesive in the reservoir for the production, the melting grill is automatically switched off and actively cooled. This protects the remaining PUR adhesive and guarantees excellent adhesive strength.

### Increased Operator Safety and Efficiency

The PUR block can be refilled without system interruption before the block has been melted completely. Since the melting grill is still covered by some adhesive, no harmful adhesive vapors can escape when the cylinder is opened.

### Reduced Costs and East of Maintenance

The melter is energy-efficient and modular, with a wide range of options such as an integrated pattern control. This optimizes the costs and allows system retrofitting at any time. For efficient maintenance, the press cylinder can be easily opened and folded back without tools.

### Your Advantages

- Demand-oriented and efficient melting thanks to innovative Melt-on-Demand technology
- Excellent adhesive strength through gentle melting with active cooling and dry gas application, as well as minimized risk of coking in the tank
- Increased line efficiency through refilling without system interruption
- Reduced costs due to modular design
- Increased operator safety – no harmful vapors, no risk of burns

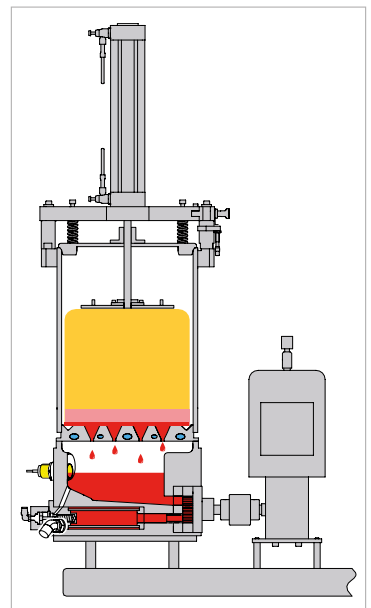

### TECHNICAL DATA

	RobaPUR 20 MOD	RobaPUR Premelt 20 MOD
Tank volume	20 liters, without inliner for PUR blocks	20 liters
Melting capacity*	25 kg/h	25 kg/h
Container size (PUR block)	Diameter 120 to 280 mm, height 120 to 320 mm	
Operating temperature	20 to 150 °C (68 to 302 °F)	
Adhesive viscosity	100 to 70,000 mPas	
Heated hose connections	8, can be extended to 12 or 16	4
Delivery pump	Max. 100 bar, continuously adjustable	Max. 30 bar
Supply voltage	400 V, 3LNPE, 50/60 Hz	
Electrical power	8.25 kW	
Compressed air supply	At least 6 bar, oil-free air acc. to Class 4	
Control panel	Membrane keyboard (TRM)	
Weight	Approx. 190 kg	
Dimensions (LxWxH)	557 x 338 x 566 mm	
Safety standard	CE	

\* Depending on adhesive, viscosity, and temperature