

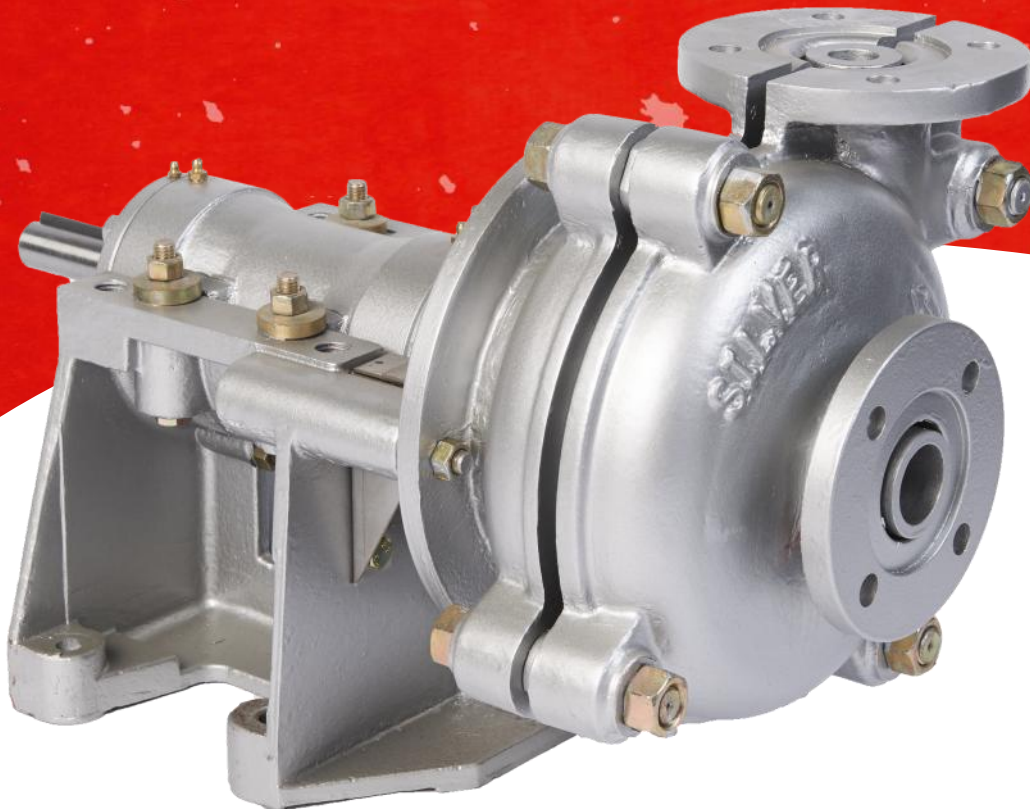

SSI.5xI-200005

SLURRYPRO[®]

A BETTER SLURRY PUMP EXPERIENCE



slurrypro.com

SSI.5x1-200005

SlurryPro Silver Series SSI.5x1-200005 centrifugal slurry pump. Featuring a standard expeller, heavy duty SKF bearing, high chrome impeller, high chrome liner and a maximum motor power of 15kW.

Performance

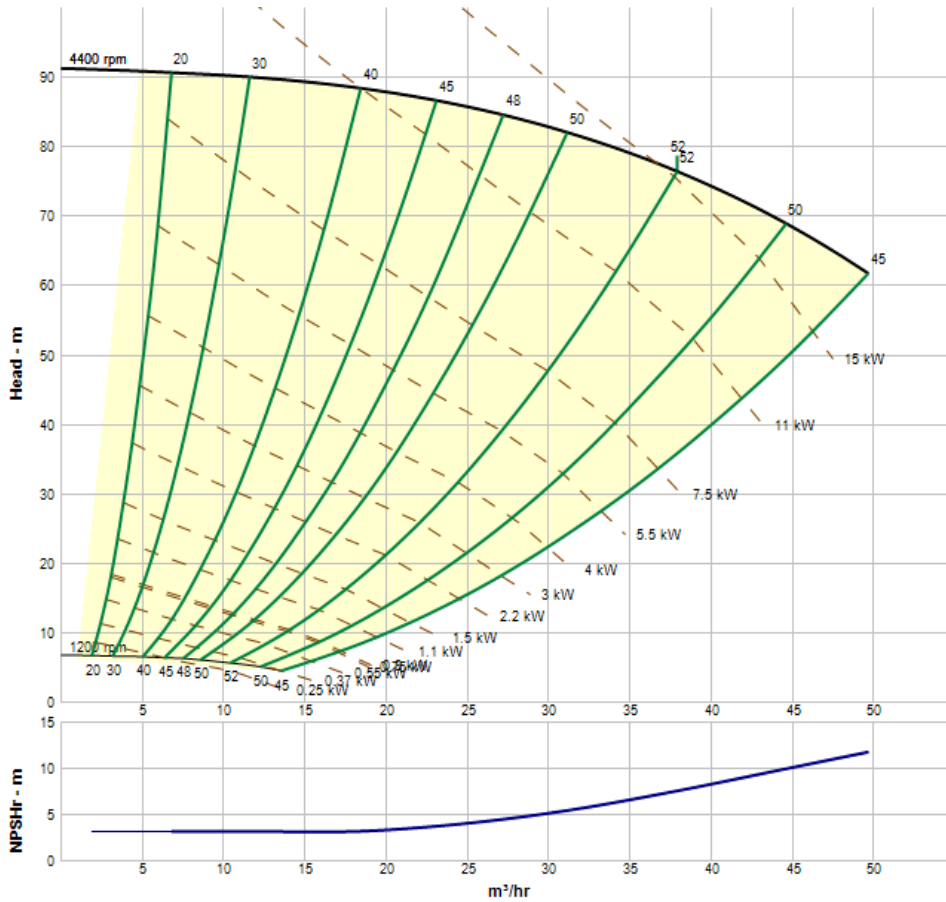

Specification

Suction	38mm (1.5")
Discharge	25mm (1")
Maximum RPM	4400
Sealing System	Expeller Seal
Impeller Material	High Chrome
Liner Material	High Chrome
Throat Bush	n/a
Max Motor Power	15kW
Weight Bare Shaft Pump	88kg

Mounting Options

Pumps can have motors mounted in the following options:

- Overhead mounted
- Side mounted
- Long coupled

About SlurryPro

SlurryPro originated from a firm belief that your slurry pump experience could and should be better. In response to industry feedback and frustration with service and response times, SlurryPro Pumps has introduced a customer-centric focus and revolutionized the end-user experience.

The core management team bring years of experience from the Australian and South American mining industry. This tough and unforgiving environment was the perfect birth place for a range of horizontal and vertical centrifugal slurry pumps focusing on superior wear life and reduced lifetime costs. We focus on the vital need to reduce downtime in our key markets of mining, chemicals and mineral processing.

We understand that reducing downtime relies on rapid and cost effective parts availability. With this in mind, we have invested heavily in stock within our distribution companies, leading to the fastest quoting and delivery times in the industry.

In short, if you're looking for a better slurry pump experience, including superior wear life, reduced lifetime cost and ease of ongoing maintenance there is quite simply no alternative to SlurryPro.

Dimensions

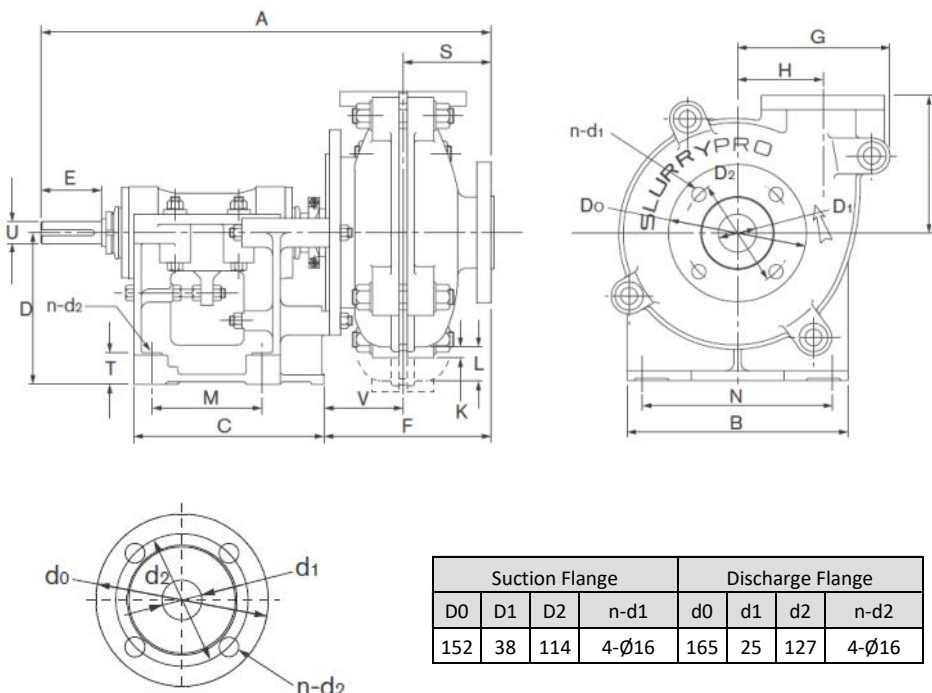

Suction Flange				Discharge Flange			
D0	D1	D2	n-d1	d0	d1	d2	n-d2
152	38	114	4-Ø16	165	25	127	4-Ø16

Size	A	B	C	D	U	E	F	G	H	J	K	L	M	N	V	T	S
1.5x1-200005	583	295	248	197	28	79	212	181	98	171	46	-	143	254	181	38	106

SLURRYPRO®

A BETTER SLURRY PUMP EXPERIENCE

e: info@intraxglobal.com

t: +44 (0)114 229 3144

Please note that the information featured on this data sheet is for guidance/reference only. For application specific drawings and curves, contact your nearest authorised distributor. SlurryPro is part of the Intrax Global Group. 020818.