

doughXpress®

Model DX-JN

Semi-Automatic Dough Divider/Rounder
Expandable Pocket Design



General Safety, Installation, Instruction & Parts Manual

NSF, USDA, ULListed

4 Machines in 1 Capability
36, 18, 9 & 6-Part Divisions
1-ounce up to 26-ounces each piece

DOUGHXPRESS

MODEL DX-JN

Semi-Automatic Dough Divider/Rounder

NSF, USDA, UL Listed
-Patented-

TABLE OF CONTENTS

	Page No.
General Rules	II - III
Machine Specifications	IV
Uncrating	1
Installation	1 - 2
Operating Instructions	2 - 5
Adjustments	5
Head Removal	5 - 7
Head Replacement	7
Head Cleaning	8 - 9
Machine Cleaning	9
Maintenance	9 - 10
Lubrication	10 - 11
Troubleshooting	11 - 12
Dough Scaling Charts (English & Metric)	13 - 14
Assembly Drawing / Parts Listings	15 - 26
Head Assemblies	27 - 30
Electrical Schematic	31 - 32
Safety Labels	33

© 2009 doughXpress, Food Equipment Division of HIX Corporation
1201 E. 27th Terrace, Pittsburg, KS 66762

DOUGHXPRESS TOLL FREE CUSTOMER SERVICE HOTLINE:
1-800-835-0606 EXT. 205

General Rules

GENERAL SAFETY RULES:

1. Equipment should not be operated with safety devices or guards removed.
2. Only qualified personnel should operate this machine.
3. Machines should not be started until all personnel are clear.
4. Service and maintenance procedures should never be performed on a machine in motion.
5. To avoid shock or serious injury, only qualified personnel should perform maintenance on the electrical system.
6. The electric power MUST be OFF before servicing the machine.

GENERAL OPERATING RULES:

1. DO NOT operate this machine until you read and understand the operating instructions and become familiar with the machine and its controls.
2. Never operate the machine with safety devices or guards removed or disconnected.
3. DO NOT start the machine until all other personnel have been warned and have moved clear of the machine.
4. Remove any tools and other foreign objects from the area around the machine.
5. DO NOT have loose clothing or unrestrained long hair near operating machinery.
6. Never sit or stand on anything that might cause you to fall against the machine.
7. Horseplay around the machine is prohibited and could cause serious injury.
8. Know the emergency stop procedure for the machine, see Pg. 5, "Emergency Stop."
9. Electrical power MUST be OFF when the machine is not in use.
10. The power switch is to be in the OFF position, and the machine disconnected from the power source, BEFORE servicing the machine..
11. DO NOT operate faulty or damaged equipment.
12. Avoid placing fingers, hands or any part of your body into the machine, or near moving parts, while operating machine.

SERVICE & MAINTENANCE:

1. DO NOT service a machine until you are thoroughly qualified, trained and familiar with the tasks to be performed.
2. Never operate any controls while other persons are performing maintenance on the machine.
3. DO NOT bypass a safety device.
4. Always use the proper tool for the job.
5. Never open covers with power on.
6. Electrical power switch is to be turned off, and machine disconnected from the power source, unless absolutely required for a specific service being performed.

ELECTRICAL:

1. All electrical maintenance and service should be performed only by trained and authorized electricians.
2. Always assume that the power is ON.
3. To remove load (power) from circuit, open disconnect or breaker, and lock in open position.
4. Make certain that the circuit is open by using the proper test equipment.. Test equipment MUST be checked at regular intervals.
5. There may be circumstances where “Trouble Shooting” on live equipment may be required. Under such conditions special precautions must be taken such as, but not limited to:
 - a. Your body and tools must be clear of the ground.
 - b. Take extra safety measures in damp areas.
 - c. Be alert and avoid any outside distractions.
6. Before applying power to any equipment, make certain that all personnel are clear of the machine.
7. Electrical panel doors, where applicable make certain the disconnect handle mechanism for electrical panel doors are operating properly.
8. Close all covers on junction panels before leaving any job.

CLEANING:

1. Turn off electrical power prior to cleaning machine.
2. DO NOT use toxic and/or flammable solvents to clean machine. Use only mild soap and water.
3. Keep panel covers closed and power off when washing a machine.
4. Always clean up spills around machine as they occur and after operating and/or cleaning.
5. Never attempt to clean a machine while it is ON or operating.

**DOUGHXPRESS
MODEL DX-JN**

Semi-Automatic Dough Divider/Rounder

Machine Specifications

Machine:

Weight (with 36-part head)	450 lb. (168 Kg.)
Size (without handle)	Width: 26-1/2" (673 mm)
	Depth: 22" (558.8 mm)
	Height: 60" (1524 mm)

Divider Head w/2 same division Dough Pallets:

Head	Part Number	Weight Lb.	Weight Kg.
36-Part C	4-436-0053 4	2 lb.	15.68 kg.
18-Part C	4-436-0051 3	9 lb.	14.56 kg.
9-Part C	4-436-0049 3	4 lb.	12.7 kg.
6-Part C	4-436-0055 3	2 lb.	11.94 kg.

Dough Pallets:

Pallet	Part Number	Pallet	Part Number
36-Part C	4-150-0003	9-Part	C4-150-0001
18-Part C	4-150-0002	6-Part	C4-150-0004

Electrical:

Standard: 208-230v 60hz 3phase (10 amp.) UL Listed

Available Options: 120v 60hz 1phase (15 amp.) UL Listed
240v 60hz 1phase (10 amp.) UL Listed
120v 50hz 1phase (15 amp.)
240v 50hz 1phase (10 amp.)
208v 50hz 3phase (10 amp.)
230v 50hz 3phase (10 amp.)

UNCRATING

This unit weighs 450 pounds, and proper equipment must be used to lift and move.

1. Set the total carton, with machine, on a flat, level surface.

CAUTION!

Carton staples are sharp - use proper tools to remove staples.

Do not pull flaps by hand before removing staples!

2. Cut carton at dotted line at bottom. Lift carton over machine, and remove plastic bag.
3. The rear and side covers on the machine must be removed. Turn the two latches $\frac{1}{4}$ turn and top edge will move outward. Lift cover upward off retainers.

IMPORTANT

The covers must be reinstalled on the machine after installation!

4. The handle, pallets, and miscellaneous components are located inside the lower base of the machine. Remove through the rear opening.
5. Remove the (4) lag bolts, one in each inside corner of the base.
6. Using proper equipment, lift machine from packing skid.

OPTIONAL HEAD ASSEMBLIES

1. Optional head assemblies are shipped in a separate carton. Remove staples from smaller carton top flaps.
2. Lift inner carton from carton. Remove head assembly from carton and packing materials. There are two dough pallets in the bottom of the outer carton. Remove the protective paper from the pallets.
3. Dispose of all cartons and packing properly.

INSTALLATION

1. Locate the (4) foundation holes inside the base in all four corners. The machine is designed to be secured to the floor, See Fig. 1. Arrange on 18 inch square pattern, (4) $\frac{3}{8}$ " diameter bolts or studs. (Bolts or studs supplied by others.)

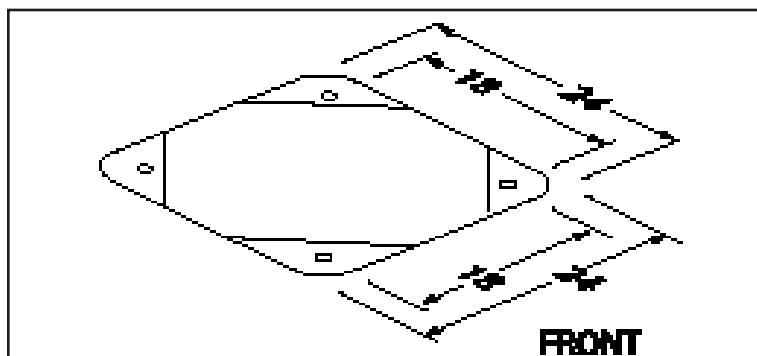

Figure 1

2. Set machine in place with bolts and/or studs properly set and tightened. Seal around the base with an approved silicone sealant. GE RTV 102 or equal.
3. Each machine must be direct wired. See proper wiring diagrams on pages 33 - 32.

CAUTION! 

**All electrical connections should be installed by an electrician.
All state, local and national electrical codes MUST be complied with.**

4. Reinstall side covers.
5. Install handle, with hole topside, fully into socket on ram lever. Tighten supplied set-screw, through hole in handle, with hex key wrench. (See Figure 2 below)
6. Apply a thin coat of sealant (RTV 102) at top edge of plastic plug supplied in package of components. Tap plug into hole over the set-screw. See Fig. 2.
7. Seal around handle at lever arm with sealant (RTV 102).

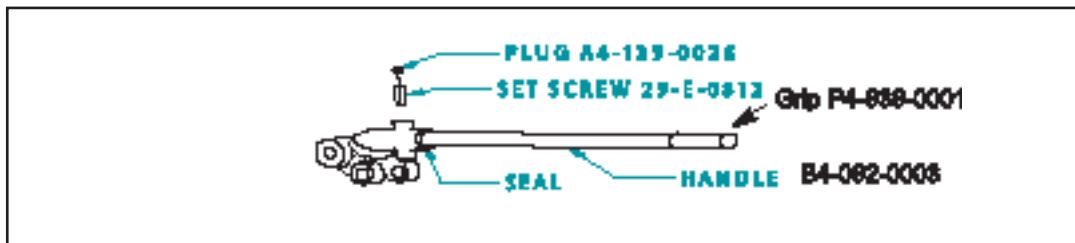

Figure 2

8. To change or install head, see instructions on pages 5 - 7.

OPERATING INSTRUCTIONS

CAUTION! 

**Machine must be fully assembled before starting or operating.
Please refer to Fig. 3, Page 4 for operation:**

1. Refer to dough weight charts for required dough piece size. See chart on pages 13 - 14

CAUTION! 

**Use only pallets supplied! Never use two pallets or shim the pallet,
as damage will occur, voiding your warranty.**

2. Place a pallet (No. 2) on a worktable. Knead or roll out the weighed dough within the inscribed circle on the pallet. (Do not use flour on pallet, as this will affect the quality of rounding)

IMPORTANT

- a. If the dough is sticky, lightly dust the top surface only with flour to prevent the dough from sticking to the head assembly (No. 3). Never flour the pallet. Do not flour the top, unless necessary.
- b. Do not use grease or oil on the dough or pallet.
- c. The dough to be divided/rounded must not have a crust.
- d. All levers and handle must be in the starting, normal position.

3. Flip the power switch to ON, and leave the motor running until the day's dividing/rounding is complete.
4. Place pallet (No. 2) with weighed dough onto the crank plate (No. 4).

CAUTION! 

The pallet must fit snugly and flat on the crank plate with the handle in the forward position. Damage will occur to the pallet, divider, and/or crank plate, if pallet is not in proper position.

5. Pull handle (No. 1) down, lowering ring (No. 5) until head assembly (No. 3) comes in contact with the dough. Now it is important for you to exert firm, even pressure on the dough for 3-4 seconds, by pulling or pushing down on the handle, forcing the dough to level, and become equal in thickness within the confines of the ring.
6. Relax the down pressure on the handle, but continue holding handle down with your right hand. With the left hand, release the tip lever (No. 6) which will release the divider. You can now push the handle to its furthest down position, dividing the dough.
7. While still holding the handle down, pull forward on the rounding lever (No. 7). This will rotate the crank plate (No. 4) and round the divided dough pieces into dough balls, (approximate rounding time required: 5-15 seconds).
8. When sufficient rotations have taken place, return the rounding lever (No. 7) to its idle position. Raise the handle (No. 1) to its uppermost position.

NOTICE

Too many, or too few revolutions during rounding will affect the final results of your dough balls. Experiments should be made to determine the correct number of revolutions necessary for your dough and product requirements.

IMPORTANT

The further forward you pull the rounding lever, the wider and faster the rounding motion becomes.

IMPORTANT

Pocket size may be adjusted higher or lower to accommodate various dough sizes and rounding consistency. This will require experimenting to obtain the correct pocket height for various products and doughy. See adjustments on Page 5, Item 1, Fig. 4.

9. Remove the pallet (No. 2) with the finished dough balls from the machine. Remove these pieces from the pallet. Repeat the above procedure for additional dividing and rounding.

NOTICE

Achieving the best results with your dough will require some experimenting with the pocket settings and rounding action. See Adjustments Pg. 5 Item 1, Fig. 4

WARNING!

Do not operate this machine without covers and canopies on and in a secured position.

doughXpress®



Figure 3

DIVIDING ONLY OPERATING INSTRUCTIONS

WARNING!

NEVER DOUBLE PALLET TO DIVIDE DOUGH AS DAMAGE TO MACHINE MAY OCCUR DUE TO THE EXTREME PRESSURE APPLIED.

1. Place pallet with dough to be divided onto crank plate (No. 4), then press dough in the same manner as described on Page 3, Item 5. After pressing and dividing dough, pull Rounding Lever (No. 7) forward slightly just enough to start the crank plate motion, then return the Rounding Lever to idle position immediately. This small motion will tear the thin membrane left between each divided piece and make removal from Pallet (No. 2) much easier.

WARNING!

Keep hands and clothing clear of all moving parts.

EMERGENCY STOP

In case of emergency, release rounding lever, flip power switch to OFF, and raise handle.

ADJUSTMENTS

All adjustments have been made at the factory, however, readjusting may be required upon installation, and periodically during use.

1. Your new DoughXpress Divider/Rounder comes equipped with an "Expandable Pocket" design. Experimentation will be required to determine the correct pocket height for each size dough ball. To increase the pocket height, loosen the locking nut by turning counter clockwise. Turn the stop rod clockwise to decrease pocket height (for smaller rolls) and counter clockwise to increase pocket height (for larger rolls). Retighten locking nut before rounding by turning clockwise. See Fig. 4.

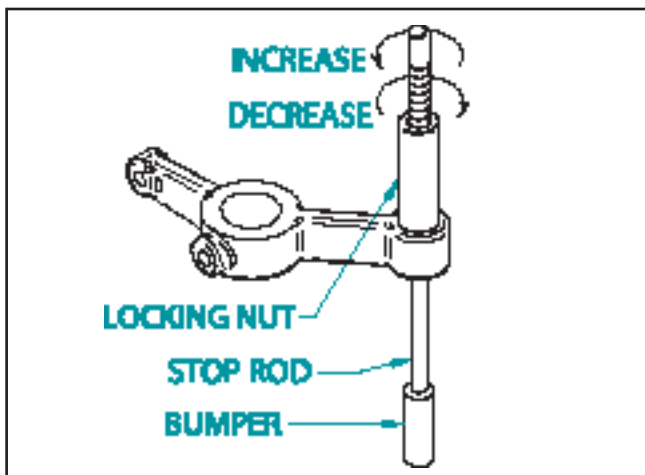

Figure 4

Note: When properly set, the Stop Rod Bumper should compress very slightly during the rounding process.

2. Motor Belt tension will require tightening as belts wear and stretch.

WARNING!

Before removing cover, place power switch in the OFF position and disconnect the machine from the power source.

To adjust, see Fig. 5. Remove cover from side of base. With a wrench, loosen locking nut, turn knob clockwise by hand to tighten belts. The belts should have approximately 1/16 inch deflection. Retighten the lock nut and replace the cover. This adjustment must be tested after being made.

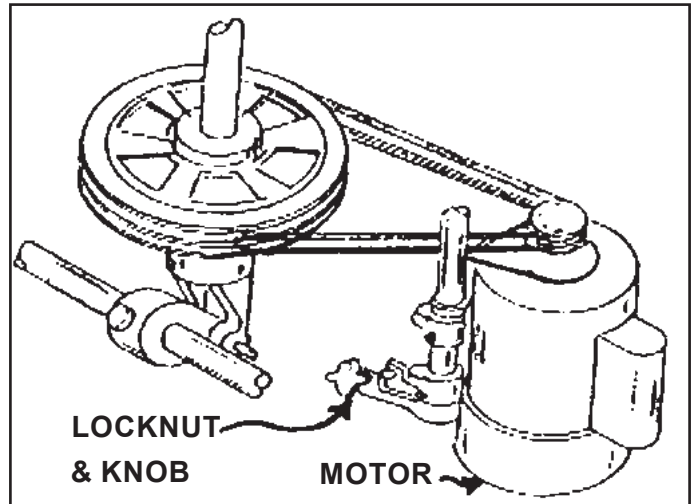

Figure 5

3. Drive Slide adjustment is to stop the crank plate in the center, when releasing the rounding lever, See Fig. 6. The crank plate must be removed to make this adjustment. (To remove crank plate, see instructions on page 10, Item 7) Loosen lock nut and turn set screw counter clockwise, to allow drive slide to come back to center. Tighten lock nut. If drive slide is coming back beyond center, loosen lock nut, turn set screw clockwise, pushing drive slide to center. Tighten lock nut.

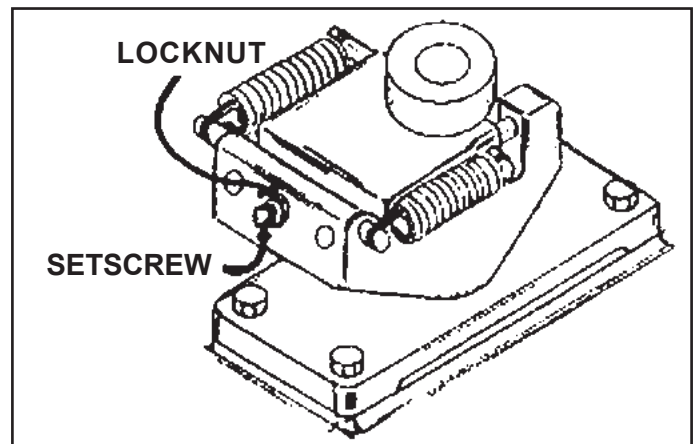

Figure 6

HEAD REMOVAL

To remove the head assembly for cleaning, or for interchanging with one of the optional head assemblies of other divisions.

CAUTION! ⚠

A pallet must be in place on the crank plate when removing and installing the head assembly

1. Remove front and rear canopies (Fig. 7, No. 5 & No. 6) by lifting up, and out.
2. Pull handle (Fig. 7, No. 1), down until ring (No. 2) is resting on pallet (No. 3).

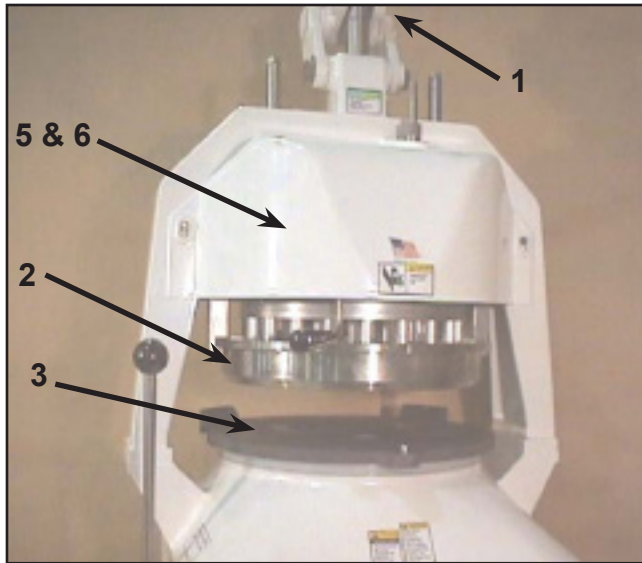

Figure 7

WARNING!

Do not release the handle from your hand, until the handle is returned to its uppermost position.

3. Hold handle in this position, grasp outer edges of the ring (Fig. 8, No. 1) keep fingers out of the divider/plug area. Rotate ring $\frac{1}{4}$ turn until slots are in line with the arms (Fig. 8, No. 2).

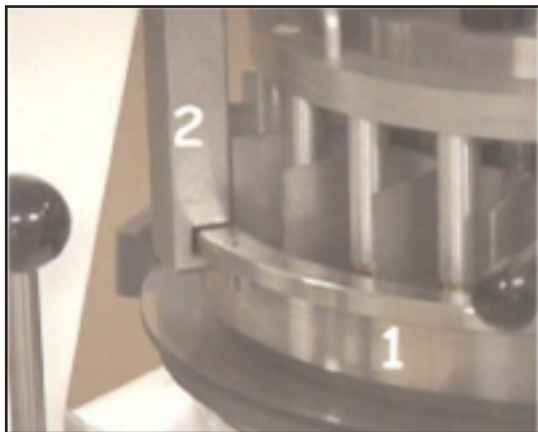

Figure 8

4. Slowly raise the handle and watch arms (No. 2) for interference. If interference occurs, lower handle and reposition the ring (No. 1). Raise handle, with no interference to its uppermost position.
5. Remove ring (Fig. 8, No. 1) from machine, set ring aside on work bench. Do not drop or bump ring as this can cause nicks or other damage to ring.
6. Loosen the two hand knobs (Fig. 10, No. 3) fully.

7. Set pocket height on the stop rod, Fig. 9, at least 1" off the trip plate. Release the trip lever (Fig 10, No. 1).

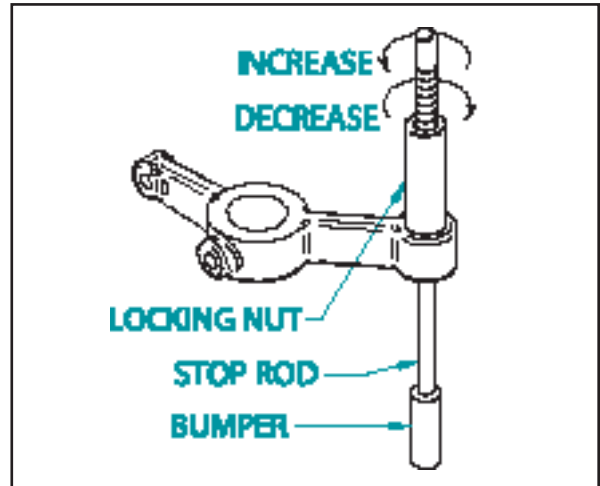

Figure 9



Figure 10

WARNING!

Do not release the handle from your hand, until the handle is returned to its uppermost position.

8. Pull handle down until head rests on pallet (Fig. 10).
9. Rotate head assembly (Fig. 10, No 2) $\frac{1}{4}$ turn clockwise.
10. Raise handle slowly, watch ram (Fig. 11) making sure it causes no interference. Continue to raise handle to uppermost position. Head assembly should be resting on the pallet.



Figure 10

- Remove head assembly (Fig. 12, No. 1). This head can now be cleaned. (See pages 8 - 9).

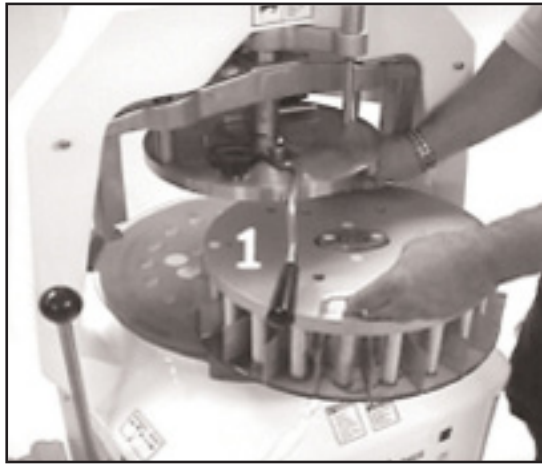

Figure 12

HEAD REPLACEMENT

- With pallet in place, position head assembly (Fig. 13, No. 1) in center of pallet with handle in front.



Figure 13

- Release the trip lever, and slowly lower the handle. Watch the lower end of the ram (Fig. 11) insertion into the head. Align the head as necessary to complete insertion.

WARNING!

Keep hand from between the head (Fig. 14, No. 2) and the trip plate (No. 3)

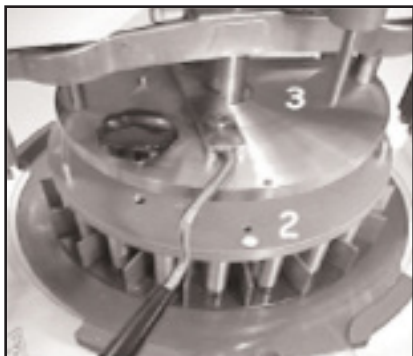

Figure 14

WARNING!

Do not release the handle from your hand, until the handle is returned to its uppermost position.

- Rotate the head assembly, Fig. 15, No. 1, ¼ turn clockwise. Alignment pin at front of trip plate, Fig. 15, No. 2, will engage in hole in head assembly, No. 1.

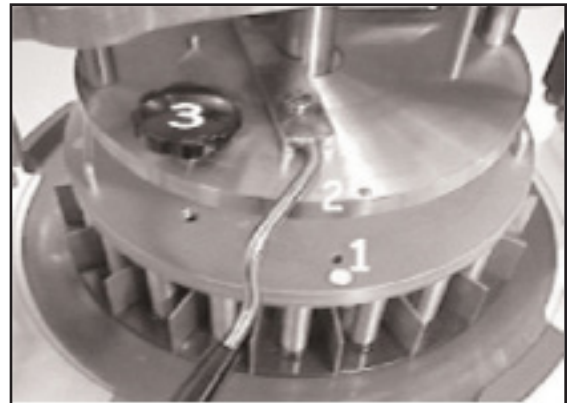

Figure 15

- Raise handle to its uppermost position.
- Tighten both hand knobs (Fig 15, No. 3).
- Set ring (Fig. 16, No. 1) on center of pallet.
- Lower handle slowly and align ring (No. 1) with head (No. 2) continue down with handle, align ring slots with arms (Fig. 16, No.3).

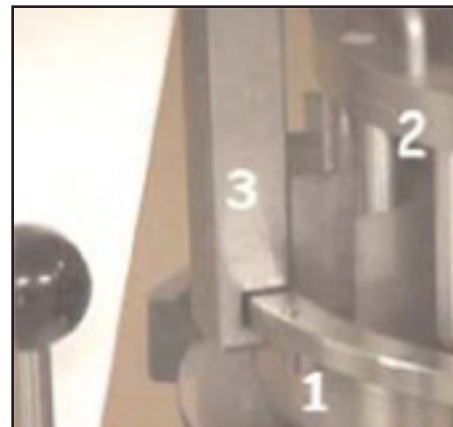

Figure 16

- Hold handle in this position, rotate ring clockwise ¼ turn, grasp ring at outer edge, keeping fingers out of divider/plug area.
- Raise the handle to its highest upright position.
- Replace front and rear canopies by aligning key holes with pins and sliding downward.

CAUTION! ⚠

The ring must be rotated clockwise until the pin rests against the ring arm.

HEAD CLEANING

CAUTION!

Do not use solvents; use only mild soap and water, or you may place entire head in dishwasher. Use care that washer sprayers will not hit head assembly as damage could occur to head.

For the best cleaning results, remove the ring and head assembly, (see instructions pages 5 - 7) and place on table. Remove divider from head assembly by removing the screws with a flat blade screwdriver through the holes in the upper plate (Fig. 17). Next, lift head by the handles. The divider will remain on the table (Fig. 18). Remove the screws and set aside for re-assembly.



Figure 10



Figure 10

The divider may then be washed in hot water with soap, rinsed and dried - **avoid bumping dividers on solid objects as this will cause damage.**

The remaining head assembly may be washed in hot water with soap, rinsed and allowed to air dry. Air drying is necessary so components will cool and allow for proper operation. To reassemble the divider into the head, place the head upside down on a table, align the longer dividers in the slots with the screw holes below. Align all the dividers with the head (Fig. 19). Slip the divider into place, adjust the screw slots (Fig. 20). While holding the divider in place, turn the entire head right side up and set on bench.

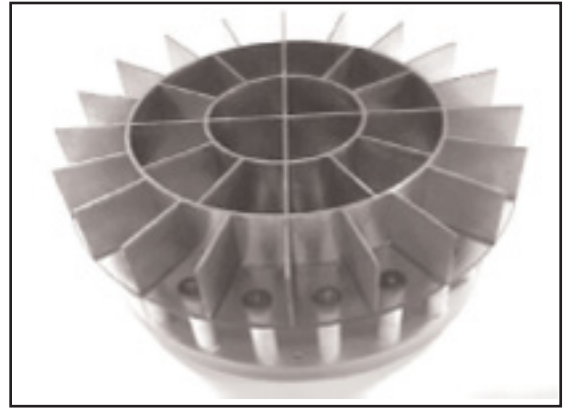

Figure 19



Figure 20

Install the screws into the divider through the holes in the top plate. Tighten the screws with the flat blade screw driver (Fig. 21).

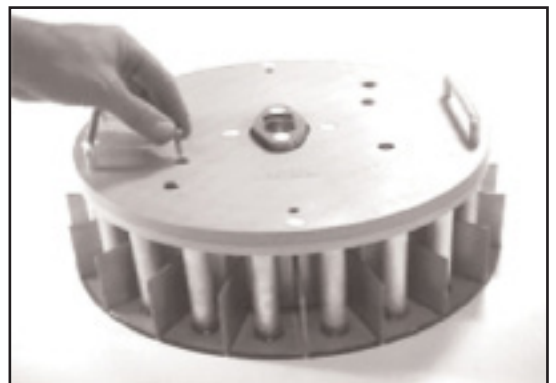

Figure 21

Wash the outside ring in hot soapy water, rinse and dry. **Do not drop or bump this ring as this will cause nicks or damage to ring.**

Wash the pallets using hot soapy water, rinse and dry. A soft brush will assist in cleaning the pallets. Never use solvents or metal scraper on pallets.

The entire head assembly (head, divider, ring, & pallets) can be placed in a dishwasher for daily cleaning. These components must be allowed to cool to room temperature before operating. **Special care should be taken when placing into dishwasher to be sure spray heads can not hit head assembly or damage could occur to head and/or dishwasher.**

CAUTION! ⚠️

Do not drop or bump the dividers or damage will occur and the machine will not operate properly.

UPPER MACHINE CLEANING

The upper section must be cleaned, using a soap and water solution. Perform this operation with the head assembly off the machine.

1. Remove the front and rear canopies by lifting up and out.

CAUTION! ⚠️

Place a solid block between the crank plate and the trip plate, to prevent movement, before proceeding.

2. Remove trip spring assembly by loosening and removing the shoulder bolt (Fig. 22).



Figure 22

3. Remove the trip lever by loosening and removing the shoulder bolt (Fig. 23)
4. Wash the entire upper area with soap and water. Rinse, then wipe dry all shafting and components.
5. Shafts, spindles, pins and pivot points should have lubrication applied. Lubrication should be a USDA approved oil ONLY! This oil should be applied sparingly. Apply oil to a clean, soft cloth and wipe these moving parts, see Lubrication on pages 10 - 11.



Figure 21

Reassembling the components:

1. Place the trip lever in slot on shaft, then install shoulder bolt and tighten (Fig. 23).
2. For trip spring replacement, place rod end on trip lever pin, install shoulder bolt and tighten (Fig. 22).
3. Install head assembly per instructions on pg. 7.

WARNING!

Machine must be fully assembled before operating.

Wipe total exterior of machine with hot soapy water. Rinse with clear water, and wipe dry.

MAINTENANCE

WARNING!

The power switch is to be in the off position, and the machine disconnected from the power source, before servicing or cleaning. Always check before beginning these operations.

This machine requires minimal maintenance, but a regular maintenance schedule should be established to assure many years of trouble-free service.

1. The head assembly should be cleaned daily. See "head assembly removal and installation." pages 5 - 7 for removal of head. The head assembly can be placed in a sink or dish washer for cleaning.
2. The pallets are made of Lexan, and can be washed daily. The pallets will scratch during regular use; however, do not use metal or other sharp objects on the pallets.
3. The crank palate should be wiped clean before each installation of the pallet. If soiled, a soap and water solution should be used. Scrape with a plastic scraper if soil buildup has occurred.

4. The exterior should be wiped down with a soap and water solution. (Do not use solvents).
5. The paint is abrasion, impact, moisture resistant, and USDA approved. If the paint should become damaged, a similar type paint should be applied.
6. The motor belts will require tightening, and when worn, replacement. For tightening, see adjustments Item 2, page 5.

BELT REPLACEMENT

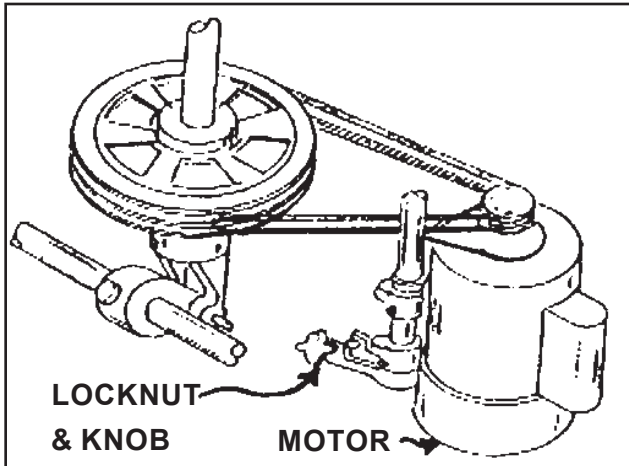

Figure 24

To replace the belts, see Fig. 24. Remove covers, loosen belt adjusting lock nut and knob totally. Remove belts from motor sheaves at top. Belts will slip down off driven sheaves over bearing cup. Pull pin from lift arm and remove belt.

To install belts, reverse procedure and complete tightening belts as shown in Adjustments, item 2 page 5.

7. To service crank bearings, slide pins, and follower (Fig. 25), remove crank plate, page 15, Item 37, by removing the forward center plastic plug, Item 2, and hex shoulder bolt, Item 1 from the crank plate. To do this, the silicone in the center of the plug must be pried out, then insert the bolt provided (*1/4"-20x3/4" Hex Hd Capecrew*) with your warranty packet into the plug, and turn clockwise until the plug can be removed. After removing the hex shoulder bolt, grasp both sides of the crank plate and lift. (See maintenance schedule, page 11). Replace crank plate. Remove bolt from plug and tap plug back into crank plate until flush with surface. Apply a small amount of silicone into hole in plug. Save the bolt for future use.

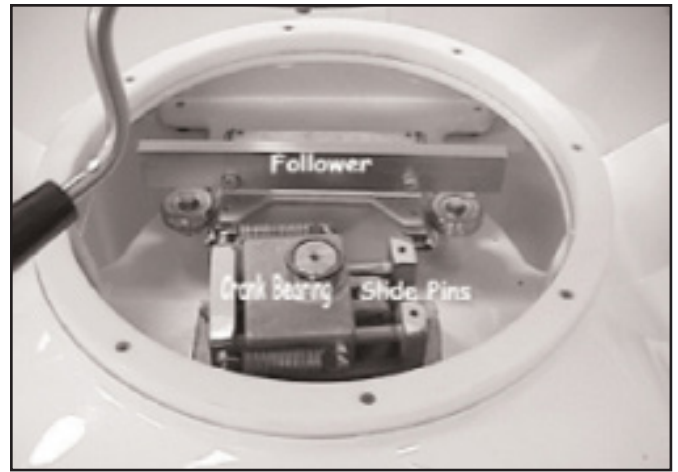

Figure 25

The components of this machine require very little maintenance, but all mechanical equipment does require periodical service for proper operation and extended life. A regular lubrication schedule should be established and followed. The frequency of lubrication must be determined by the user.

LUBRICATION

Type of Lubrication:

**OIL: Must be a USDA approved food grade.
May be a spray type.**

Grease: Must be a USDA approved grease.

CAUTION! 

The power switch is to be in the OFF position and the machine disconnected from the power source before servicing.

IMPORTANT

Always clean excess grease and oil from the machine and surrounding area.

MAINTENANCE SCHEDULE

The following information is to be used as a guide:

	ITEM	LUBE	METHOD	FREQUENCY	FIG./PG.
1.	Spindles	Oil	Wipe	After Cleaning	Fig. 7, Pg. 6
2.	Ram Pin	Oil	Wipe	After Cleaning	Fig. 7, Pg. 6
3.	Linkage Pins	Oil	Drop	After Cleaning	Fig. 22, Pg. 9
4.	Follower	Oil	Wipe	Yearly	Fig. 25, Pg. 10
5.	Crank Bearing	Grease	Pack	Yearly	Fig. 25, Pg. 10
6.	Slide Pins	Oil	Wipe	Yearly	Fig. 25, Pg. 10

TROUBLESHOOTING

If a problem should continue after having attempted the corrective solutions found on Pages 10 - 11, Please call the DoughXpress Customer Service Hotline Number 1-800-835-0606

Problem

Solution

Rounding will not take place:

- | | |
|------------------------------|--|
| 1. Drive belts slipping: | -Adjust belts, see Adjustments, Item 2 Page 5. |
| 2. Motor not operating: | |
| a. Motor overload tripped | -Set switch to stop position, allow motor to cool, push reset on lower end of motor. Replace cover, start machine.
- Single phase machines reset is located in the on/off switch. Push downward on the switch then turn the machine back on. |
| b. Switch faulty | -Replace switch. |
| c. No incoming power | -Check circuit breaker of fuses, incoming power. |
| 3. Lift arm loose: | Reposition and tighten in lower base. |
| 4. Slide rod/drive sticking: | Clean slide rods and lubricate under crank plate. |
| 5. Follower sticking: | Clean follower tracks and lubricate bearings under crank plate. |

Dough Balls Vary In Size:

Dough needs to be pressed out with more pressure on handle.
-Knead or roll dough evenly within the inscribed circle on the dough pallet before pressing.

Dough Sticks To Head:

Dust the top of the dough only, with a light dusting flour prior to pressing.
-Head assembly not clean, wash and dry head assembly, see Cleaning instructions on pages 8 - 9.

TROUBLESHOOTING

Problem

Solution

Partial Rounding of Dough Balls:

- | | |
|--------------------------------|---|
| 1. Pocket height set too high: | -Readjust pocket height, see Adjustments, Pg. 5. |
| 2. Rounding time too short: | -Increase rounding time. |
| 3. Pallet is oily or floured: | -Wash and dry pallet. |
| 4. Drive "Belts slipping: | -Adjust or replace belts, see Adjustments, Item 2, pg. 5. |

Flour Pocket in Dough Ball:

-Use less flour on top of dough.

Imperfection of Dough Ball:

-Usually caused by over, or under rounding.
(Normal rounding time: 5 - 15 seconds.)
-Pocket height set too high or too low.
(Raise or lower as needed.)

Rounding Action Will Not Stop:

Rounding lever not returning to
idle position:

-Lubricate linkage.
-Check slide springs.

Crank Plate will Not Center:

-Adjust drive slide centering, see adjustment pg. 5.

- | | |
|---------------------------------|---------------------------|
| 1. Broken slide spring: | -Replace spring. |
| 2. Slides/drive slide sticking: | -Clean slides, lubricate. |

WARNING!

The power switch is to be in the OFF position, and the machine disconnected from the power source, before servicing or cleaning.

DOUGH SCALING CHARTS IN POUNDS & OUNCES

The weights listed on this chart, are based on average viscosity dough.
The minimum and maximum dough weights indicated on this sheet may increase,
or decrease, according to dough viscosity.

36-Part Head Assembly

Total wt. of dough in Pounds & Ounces	Each roll in Ounces
2 lb. 4 oz.	1 oz.
2 lb. 13 oz.	1-1/4 oz.
3 lb. 6 oz.	1-1/2 oz.
3 lb. 15 oz.	1-3/4 oz.
4 lb. 8 oz.	2 oz.
5 lb. 1 oz.	2-1/4 oz.
5 lb. 10 oz.	2-1/2 oz.
6 lb. 3 oz.	2-3/4 oz.

9-Part Head Assembly

Total wt. of dough in Pounds & Ounces	Each roll in Ounces
3 lb. 15 oz.	7 oz.
4 lb. 8 oz.	8 oz.
5 lb. 1 oz.	9 oz.
5 lb. 10 oz.	10 oz.
6 lb. 3 oz.	11 oz.
6 lb. 12 oz.	12 oz.
7 lb. 5 oz.	13 oz.
7 lb. 14 oz.	14 oz.
8 lb. 7 oz.	15 oz.
9 lb.	1 lb.
9 lb. 9 oz.	1 lb. 1 oz.
10 lb. 2 oz.	1 lb. 2 oz.

18-Part Head Assembly

Total wt. of dough in Pounds & Ounces	Each roll in Ounces
3 lb. 6 oz.	3 oz.
3 lb. 15 oz.	3-1/2 oz.
4 lb. 8 oz.	4 oz.
5 lb. 1 oz.	4-1/2 oz.
5 lb. 10 oz.	5 oz.
6 lb. 3 oz.	5-1/2 oz.
6 lb. 12 oz.	6 oz.
7 lb. 4 oz.	6-1/2 oz.
7 lb. 13 oz.	7 oz.

6-Part Head Assembly

Total wt. of dough in Pounds & Ounces	Each roll in Ounces
6 lb. 12 oz.	1 lb. 2 oz.
7 lb. 2 oz.	1 lb. 3 oz.
7 lb. 8 oz.	1 lb. 4 oz.
7 lb. 14 oz.	1 lb. 5 oz.
8 lb. 4 oz.	1 lb. 6 oz.
8 lb. 10 oz.	1 lb. 7 oz.
9 lb.	1 lb. 8 oz.
9 lb. 6 oz.	1 lb. 9 oz.
9 lb. 12 oz.	1 lb. 10 oz.

DOUGH SCALING CHARTS IN GRAMS

The weights listed on this chart, are based on average viscosity dough.
The minimum and maximum dough weights indicated on this sheet may increase,
or decrease, according to dough viscosity.

36-Part Head Assembly

Total wt. of dough in Grams	Each roll in Grams
1080	30
1260	35
1440	40
1800	50
2160	60
2340	65
2700	75
2880	80
3660	85

9-Part Head Assembly

Total wt. of dough in Grams	Each roll in Grams
2070	230
2250	250
2520	280
2790	310
3060	340
3330	370
3555	395
3825	425
4082	450

18-Part Head Assembly

Total wt. of dough in Grams	Each roll in Grams
1800	100
2016	112
2250	125
2520	140
2790	155
3150	175
3330	185
3600	200
3780	210

6-Part Head Assembly

Total wt. of dough in Grams	Each roll in Grams
3060	510
3240	540
3420	570
3570	595
3750	625
3930	655
4080	680
4260	710
4410	735

BASE ASSEMBLY DRAWING

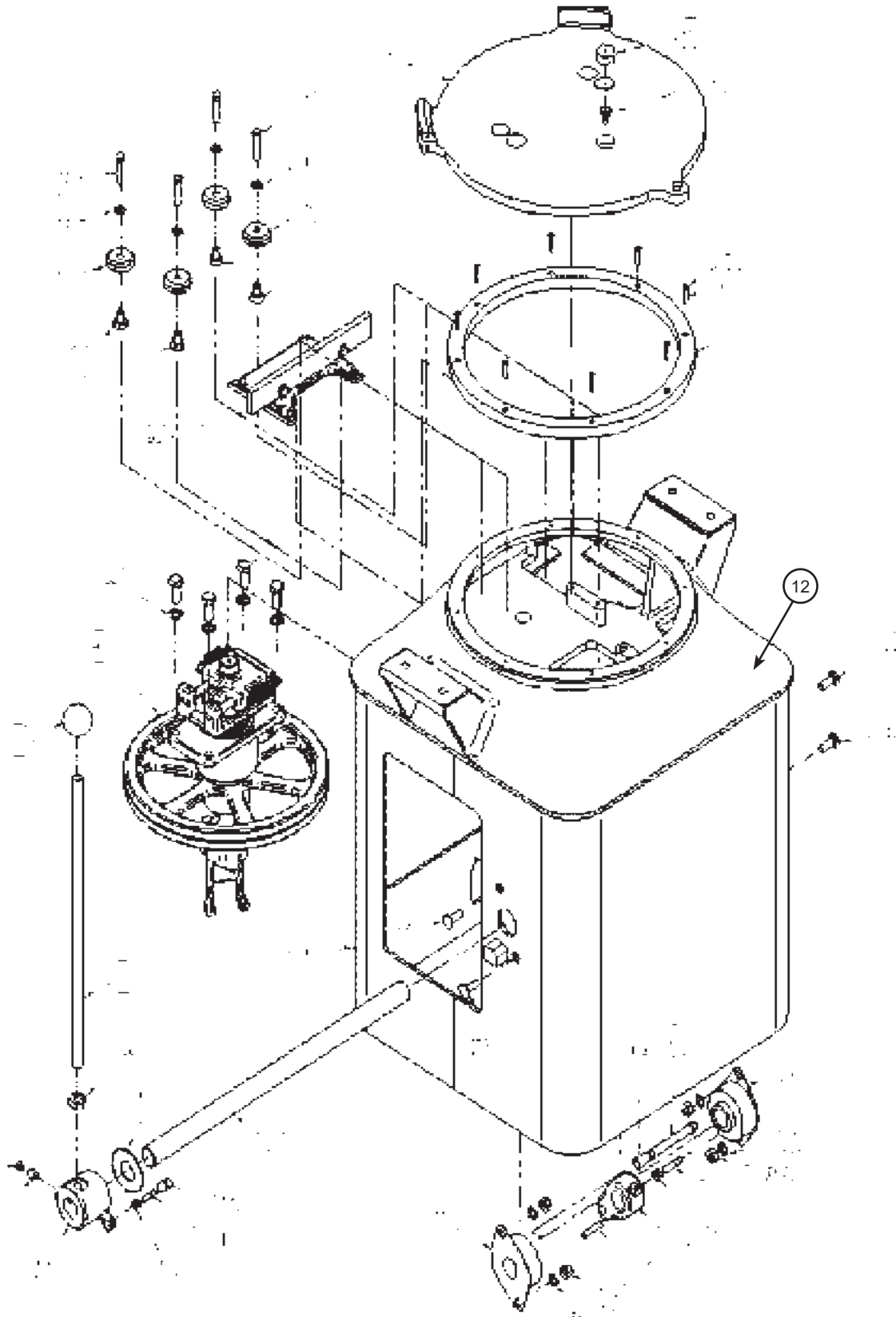

BASE ASSEMBLY PARTS

Item	Qty.	Description	Part Number
10	1	Lower Base, Painted	B4-030-0002
12	1	Upper Base, Painted	C4-030-0010
29	4	Wheels, Dual-Vee W 3SSX	P4-905-0001
30	2	Bushings, Stationary	P4-902-0002
31	2	Bushings, Adjustable	P4-905-0003
32	4	Hex Head Cap Screw	11-S-0514
33	4	Intl. Tooth Lock Washer	64-H-05
35	1	Shoulder Screw	A4-033-0009
36	1	Plug with Insert	A4-139-0010
37	1	Crank Plate Sub-Assembly	B4-436-0035
49	1	Rounding Lever w/Stop	A4-045-0003
51	1	Sq. Hd. Set Screw	30-E-0508
52	1	Hex Jam Nut	45-E-05
55	1	Rounding Lever	A4-045-0006
56	1	Knob, Ball	P4-939-0004
57	1	Lift Arm Shaft	A4-053-0007
58	1	Hex Jam Nut	45-E-60
87	8	Flat Hd. Ph. Mach. Screw	22-E-0308
88	1	Thrust Washer, Crank Plate	A4-020-0015
89	2	Bearing	P4-903-0021
90	1	Drive Sub-Assembly	B4-436-0037
91	4	Hex Hd. Cap Screw	11-E-0810
92	4	Intl. Tooth Lock Washer	64-H-08
93	1	Follower Sub-Assembly	B4-436-0038
101	1	Arm Shaft Thrust Washer	A4-020-0002
102	1	Lift Arm, Drive	A4-044-0005
103	1	Bushing, Lift Arm	P4-909-0019
104	1	Sq. Hd. Set Screw	30-E-0612
105	1	Hex Jam Nut	45-E-06
106	1	Key	S-E-05-05-12
107	1	Pin	P4-957-0002
163	2	Skt. Set Screw, Knurled Cup Point	32-Y-0805
188	1	Plug, Set Screw	A4-139-0026
891	4	Carriage Bolts	15-E-0708
892	4	Hex Nut	41-E-07
893	4	Intl. Tooth Lock Washer	64-H-07

YOKE ASSEMBLY DRAWING

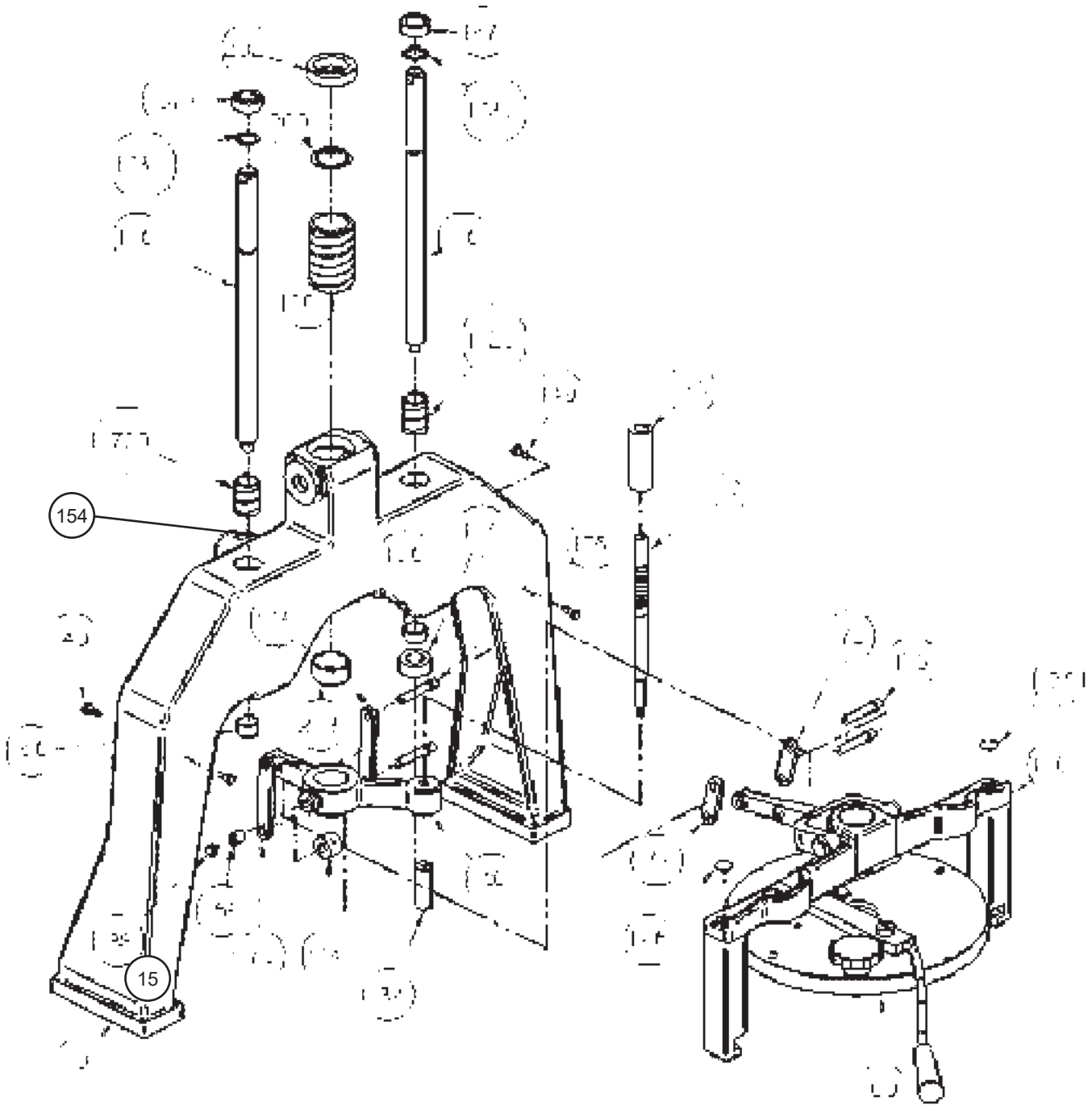

YOKE ASSEMBLY PARTS

Item	Qty.	Description	Part Number
15	1	Yoke, Painted	C4-088-0012
109	1	Trip Plate Sub-Assembly	B4-436-0040
120	1	Ring Yoke Sub-Assembly	B4-436-0039
126	2	Plug	A4-139-0025
132	1	Stop Rod	B4-074-0008
133	1	Locking Nut for Stop Rod	A4-019-0009
134	1	Stop Rod Bumper	A4-123-0001
149	4	Post for Canopy	A4-033-0007
154	1	Ring Lift Support	B4-091-0122
156	2	Bushing	P4-909-0002
157	2	Bushing, Spindle Top	A4-024-0030
163	2	Skt. Set Screw, Knurled Cup Point	32-Y-0805
165	1	Stop Collar, Fixed Pocket	B4-022-0008
172	2	Swing Link	A4-044-0007
173	2	Lift Link	A4-044-0008
174	1	Lift Roller	A4-076-0005
175	4	Pin	P4-957-0003
176	1	Spindle, Fixed Pocket	A4-145-0004
177	1	Shaft Collar	P4-935-0015
200	1	Retaining Ring	P4-957-0030
201	1	Ram Spring	P4-965-0018
202	1	Ram Bushing	A4-024-0035
203	1	Bushing, Yoke	P4-909-0017
1720	2	Spindle Spring, Compression	P4-965-0011
1730	2	Retaining Ring	P4-957-0001

RAM ASSEMBLY DRAWING

Note: See Page 2 for Handle, Grip, Set Screw and Plug part numbers.

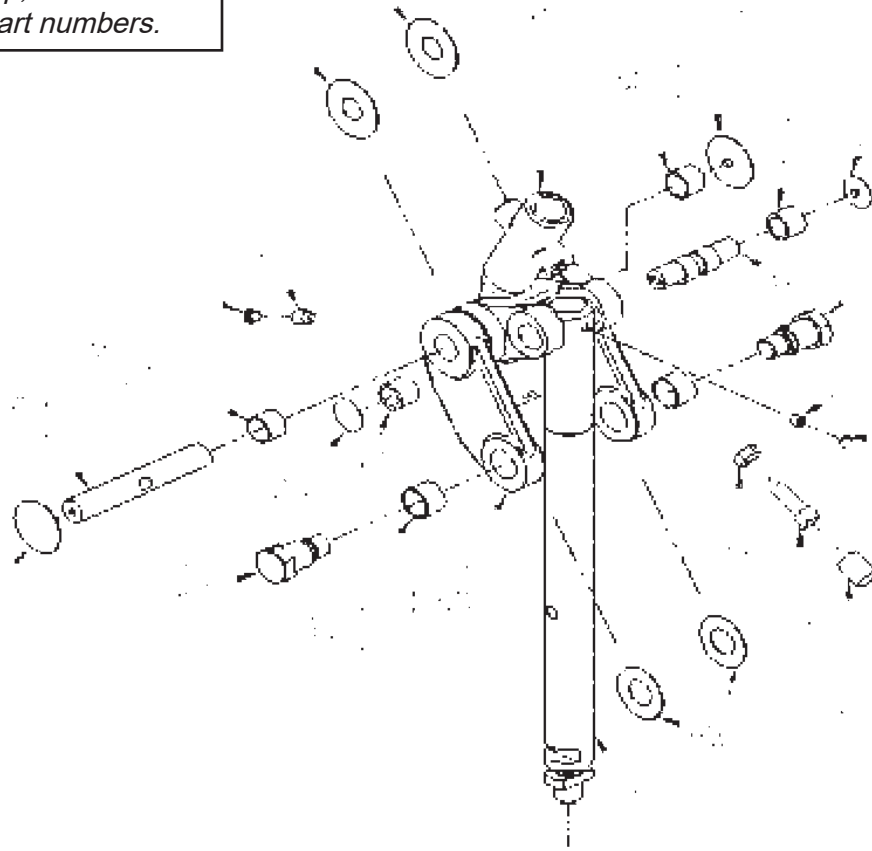

RAM ASSEMBLY PARTS

Item	Qty.	Description	Part Number
159	1	Pivot Arm	B4-044-0016
160	2	Pivot Bolt	A4-033-0008
161	1	Ram Lever	B4-045-0029
162	1	Shaft, Pivot Arm	A4-053-0080
163	3	Skt Set Screw, Knurled Cup Pt.	32-Y-0805
164	1	Ram	B4-064-0005
168	1	Ram Pin	A4-066-0025
169	2	Plug, Ram Pin Ends	A4-139-0024
170	2	Bushing, Ram	P4-909-0020
171	1	Skt Set Screw	29-Y-0603
185	1	Sq Hd Set Screw	30-E-0810
186	1	Hex Jam Nut	45 E-08
187	1	Shrink Tubing	P4-921-0035
188	3	Plug, Set Screw	A4-139-0026
204	2	Cover, Shaft End	A4-063-0002
1591	2	Bushing	P4-909-0015
1593	2	Spacer	A4-021-0011
1601	2	Bushing	P4-909-0016
1602	2	Spacer Washer	A4-021-0010
1711	1	Plug, Ram Pin Ends	A4-139-0007

CRANK PLATE SUB-ASSEMBLY DRAWING

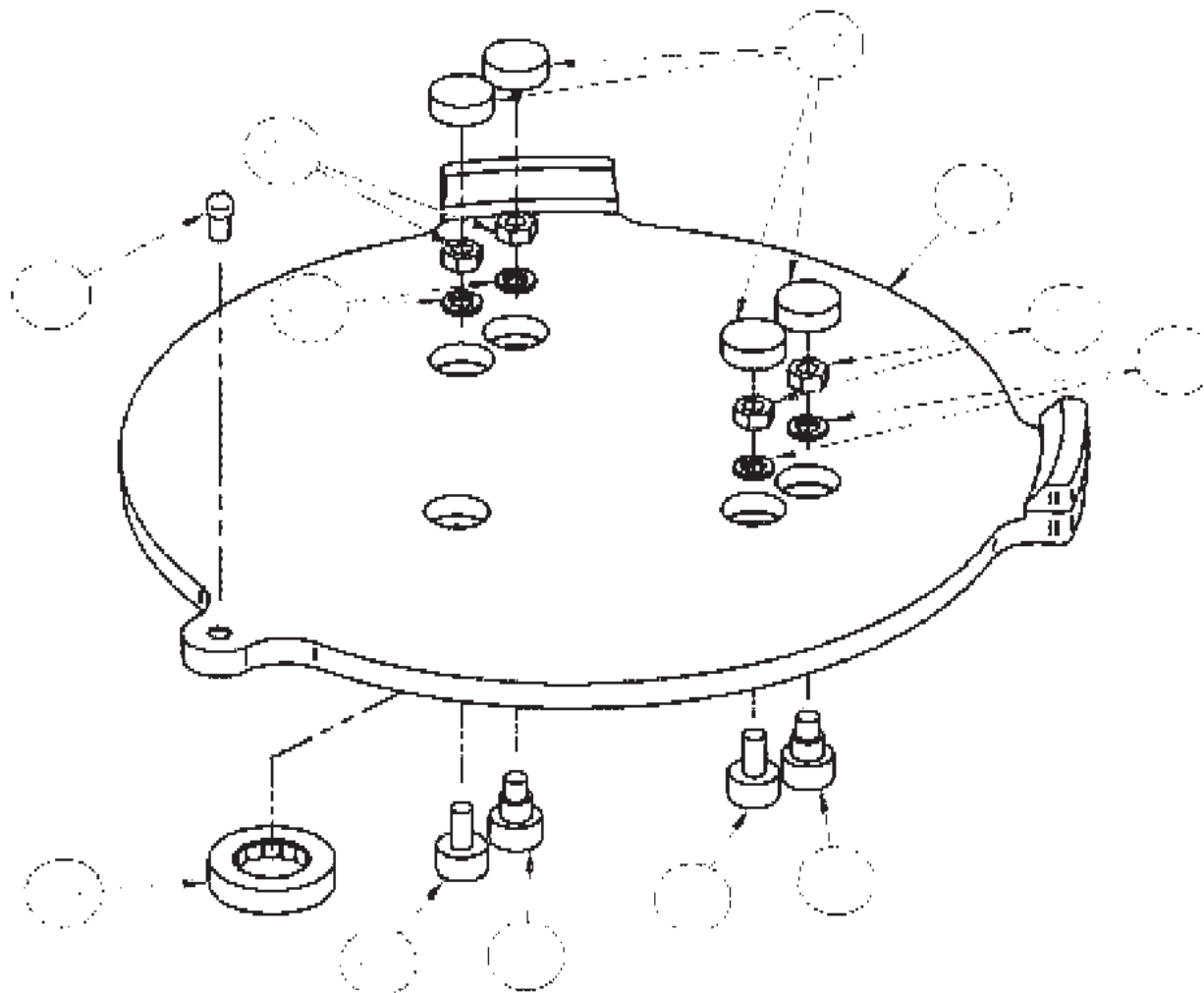

CRANK PLATE PARTS

Item	Qty.	Description	Part Number
38	1	Crank Plate Hard Coated	B4-147-0031-P
39	1	Bearing, Crank Plate	P4-903-0020
40	2	Cam Follower	P4-903-0018
41	2	Cam Follower, Eccentric	P4-903-0019
42	4	Spring Lock Washer	63-E-07
43	4	Hex Nut	41-E-57
47	4	Crank Plate Plugs	A4-139-0023
48	1	Pallet Pin	A4-066-0044

TRIP SPRING SUB-ASSEMBLY DRAWING

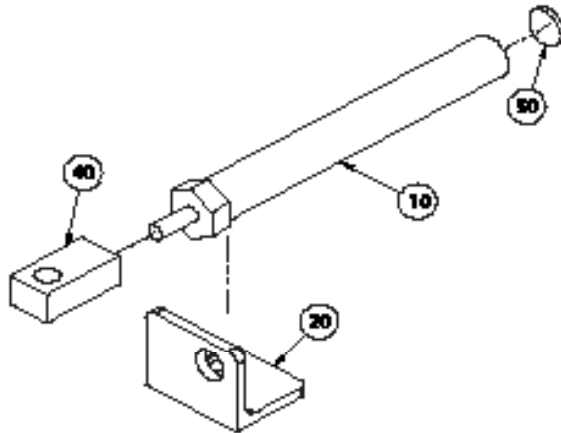

TRIP SPRING SUB-ASSEMBLY PARTS

Item	Qty.	Description	Part Number
10	1	Cylinder	P4-919-0002
20	1	Mounting Bracket	A4-091-0127
40	1	Rod End	A4-127-0002
50	1	Filter	P4-935-0017

TRIP PLATE SUB-ASSEMBLY DRAWING

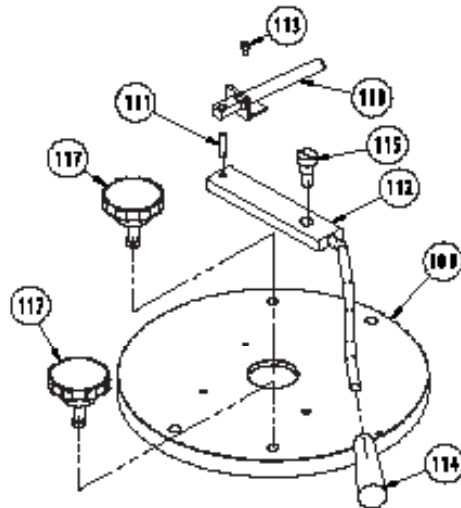

TRIP PLATE SUB-ASSEMBLY PARTS

Item	Qty.	Description	Part Number
109	1	Trip Plate, Fixed Pocket	B4-147-0082
110	1	Trip Spring Sub-Assembly	A4-436-0041
111	2	Pin	73-E-0816
112	1	Trip Lever	B4-436-0042
113	1	Slotted Shoulder Screw	83-E-0301
114	1	Knob, Tapered Grasp	P4-939-0006
115	1	Slotted Shoulder Screw	83-E-0804
117	2	Trip Plate Knob Sub-Assembly	A4-436-0043

FOLLOWER SUB-ASSEMBLY DRAWING

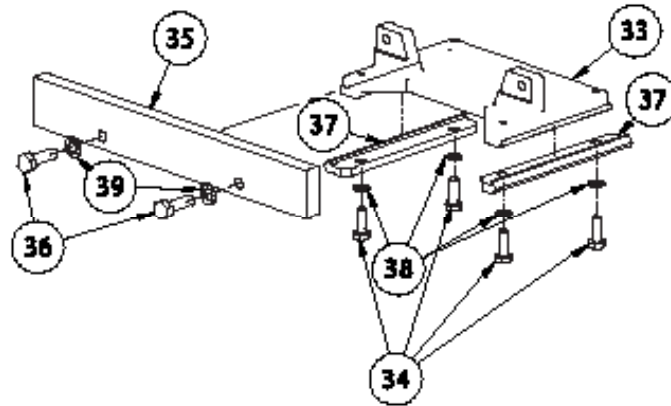

FOLLOWER SUB-ASSEMBLY PARTS

Item	Qty.	Description	Part Number
33	1	Track Support	B4-091-0123
34	4	Hex Hd. Cap Screw	11-E-0406
35	1	Follower Bar	A4-136-0003
36	2	Hex Hd. Cap Screw	11-E-0508
37	2	Track, Dual-Vee	A4-100-0001
38	4	Intl. Tooth Lock Washer	64-H-04
39	2	Intl. Tooth Lock Washer	64-H-05

MOTOR BASE SUB-ASSEMBLY DRAWING

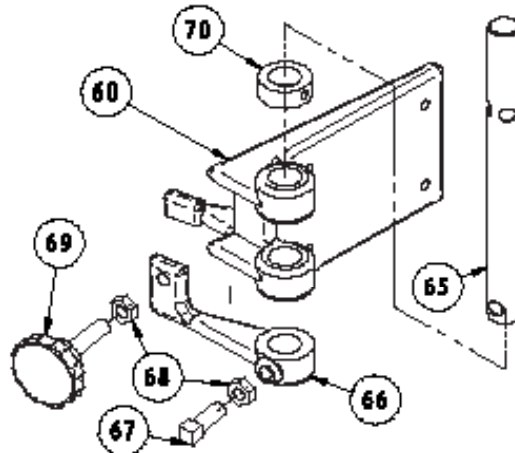

MOTOR BASE SUB-ASSEMBLY PARTS

Item	Qty.	Description	Part Number
60	1	Motor Base	B4-030-0005
65	1	Motor Pin	A4-066-0008
66	1	Motor Adjust Arm	A4-044-0009
67	1	Sq. Head Set Screw	30-E-0810
68	2	Hex Jam Nut	45-E-08
69	1	Knob, Fluted	P4-939-0005
70	1	Collar	P4-935-0016

DRIVE SUB-ASSEMBLY DRAWING

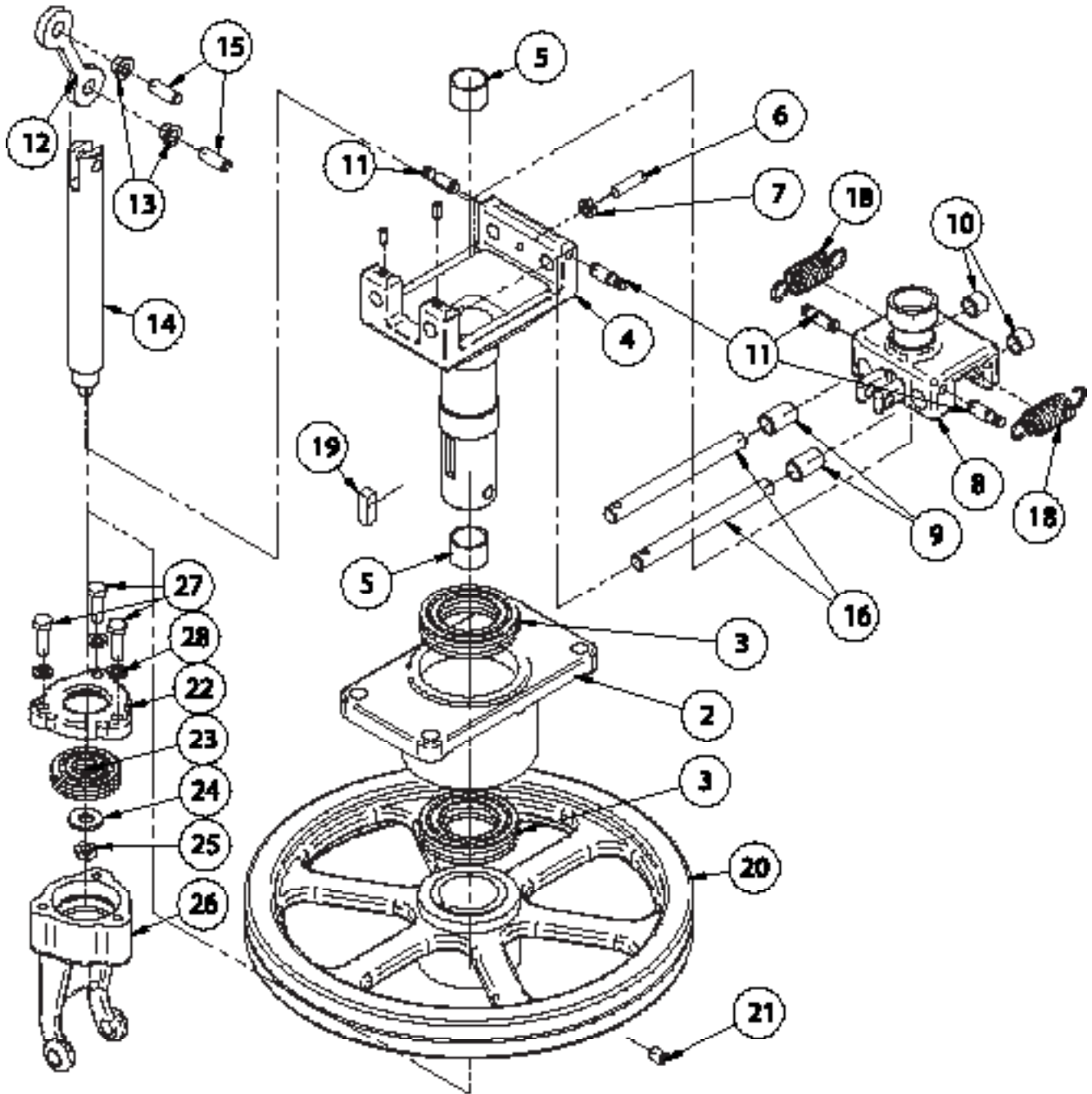

DRIVE SUB-ASSEMBLY PARTS

Item	Qty.	Description	Part Number
20	1	Bearing Mount	B4-058-0024
3	2	Bearing, Drive	P4-903-0017
4	1	Slide Yoke, Drive	C4-088-0003
5	2	Bushing	P4-909-0016
6	1	Socket Set Screw	29-E-0510
7	1	Hex Jam Nut	45-E-05
8	1	Drive Slide	B4-142-0003
9	2	Bushing, Long Slide	P4-909-0011
10	2	Bushing, Short Slide	P4-909-0010
11	4	Pin	77-D-1020
12	1	Connecting Link	A4-044-0012
13	2	Bushing	P4-909-0005
14	1	Push Rod	A4-064-0006
15	2	Threaded Pin	A4-033-0022
16	2	Slide Rod	A4-064-0007
17	2	Socket Set Screw	29-Y-0404
18	2	Spring, Drive Slide	A4-082-0003
19	1	Key	S-F-06-06-08
20	1	Two Groove Sheave	B4-098-0001
21	1	Socket Set Screw	29-Y-0604
22	1	Yoke Cap, Drive	A4-016-0004
23	1	Bearing	P4-903-0022
24	1	Flat Washer	P4-927-0015
25	1	Hex Jam Nut	45-E-06
26	1	Drive Bearing Cup	C4-058-0026
27	3	Hex Head Cap Screw	11-E-0508
28	3	Spring Lock Washer	63-E-05

RING YOKE SUB-ASSEMBLY DRAWING

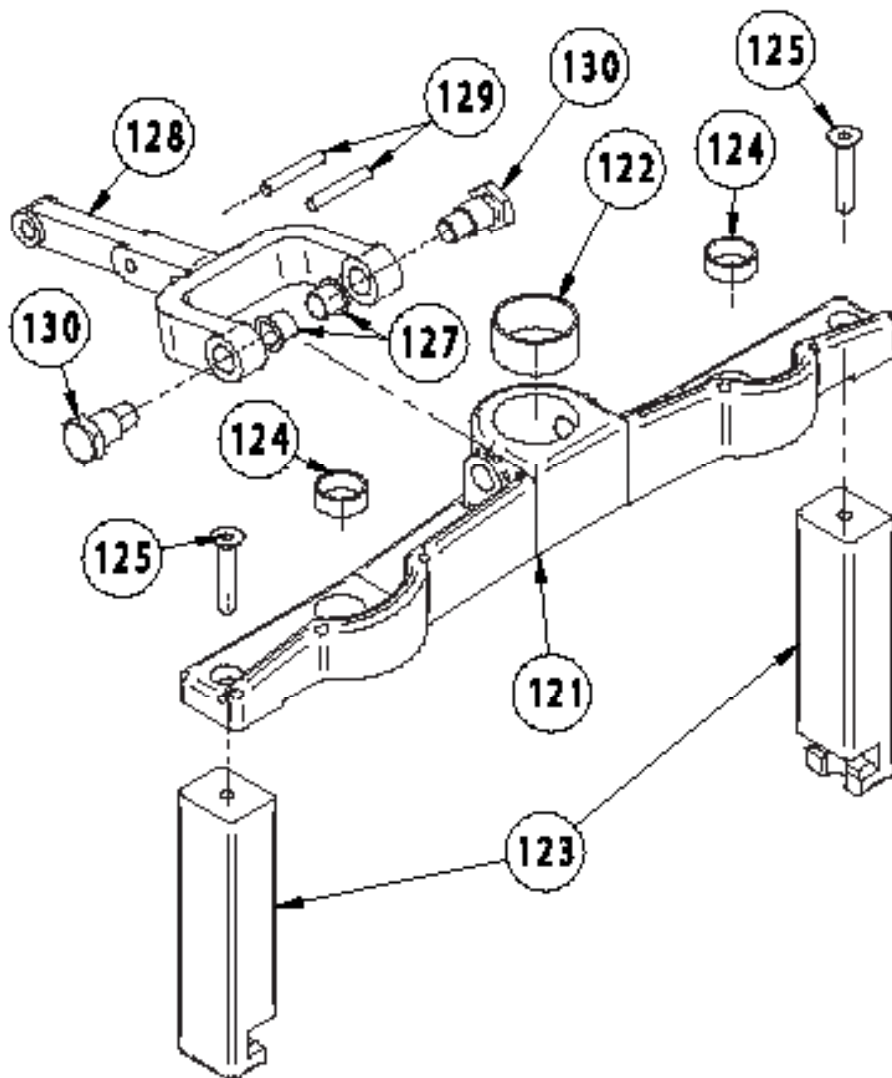

RING YOKE SUB-ASSEMBLY PARTS

Item	Qty.	Description	Part Number
121	1	Ring Yoke	B4-088-0007
122	2	Bushing, Ring Yoke	P4-909-0017
123	2	Ring Arm	B4-091-0125
124	2	Bushing, Ring Yoke	P4-909-0013
125	2	Flat Hd. Socket Cap Screw	13-E-0510
127	2	Bushing, Ring Lever	P4-909-0021
128	1	Ring Lever	B4-045-0030
129	2	Drive Pin	75-D-0824
130	2	Pivot Bolts	A4-033-0010

FINAL ASSEMBLY DRAWING

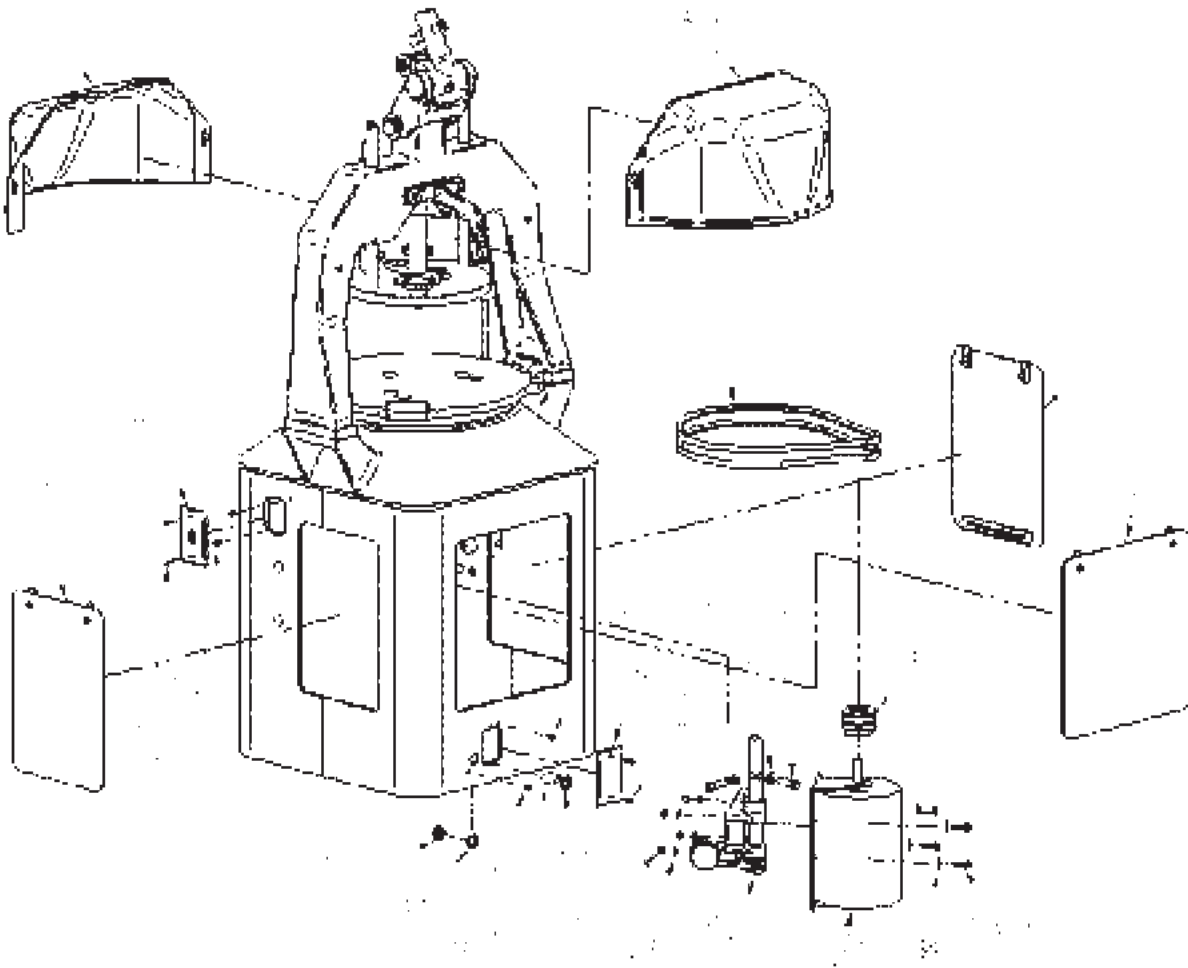

FINAL ASSEMBLY (ELECTRICAL) PARTS

Item	Qty.	Description	Part Number
10	2	Square Hd. Set Screw	30-E-0812
20	2	Hex Jam Nut	45-E-08
30	1	Motor Base Sub-Assembly	B4-436-0020
31	4	Hex Hd. Cap Screw	11-E-0508
32	4	Hex Nut	41-E-05
33	4	Intl. Tooth Lock Washer	64-H-05
34	4	Flat Washer	61-E-05
40	1	Motor (Standard Electrical, 208-240v/60hz/3ph) Call for Part Number of other electrical	P4-923-0004
50	1	Sheave (60 HZ)	P4-951-0004
		Sheave (50 HZ)	P4-951-0009
52	2	V-Belt	P4-951-0010
70	2	Side Panel Sub-Assembly	A4-436-0046
80	1	Rear Panel Sub-Assembly	A4-436-0047
120	1	Front Canopy	C4-151-0005
130	1	Rear Canopy	C4-151-0006

Item #'s 53, 54, 55, 56, 57, 59, 60, 64 Call factory for part numbers

36-PART DIVIDER HEAD ASSEMBLY DRAWING

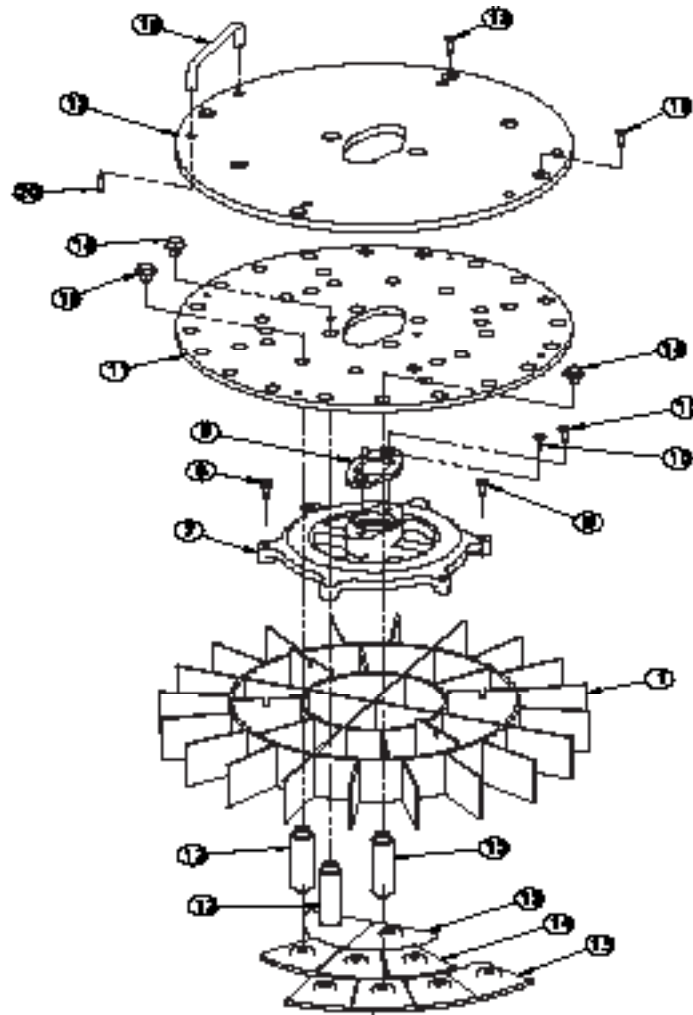

36-PART DIVIDER HEAD ASSEMBLY PARTS

Item	Qty.	Description	Part Number
1	1	36-Part Divider	B4-141-0012
7	1	Divider Plate, 36 & 18 - Part	C4-147-0061
8	4	Fil. Hd. Slotted Mach. Screw	23-E-0406
9	1	Keeper	A4-109-0006
10	2	Flat Head Phillips Mach. Screw	22-E-0405
11	1	Plug Plate, 36 & 18 - Part	B4-147-0063
12	36	Stems for Plug	A4-054-0004
13	4	Inside Plug, 36-Part	A4-139-0015
14	12	Intermediate Plug, 36-Part	A4-139-0016
15	20	Outside Plug, 36-Part	A4-139-0017
16	36	Hex Hd. Washer Type Cap Screw	P4-927-0113
17	1	Cover Plate, 36 & 18 - Part	B4-147-0064
18	6	Flat Hd. Ph. Mach. Screw	22-E-0406
19	2	Handle	P4-939-0010
20	4	Flat Hd. Slotted Mach Screw	22-E-0204
	2	36-Part Dough Pallet (Not Shown)	C4-150-0003

18-PART DIVIDER HEAD ASSEMBLY DRAWING

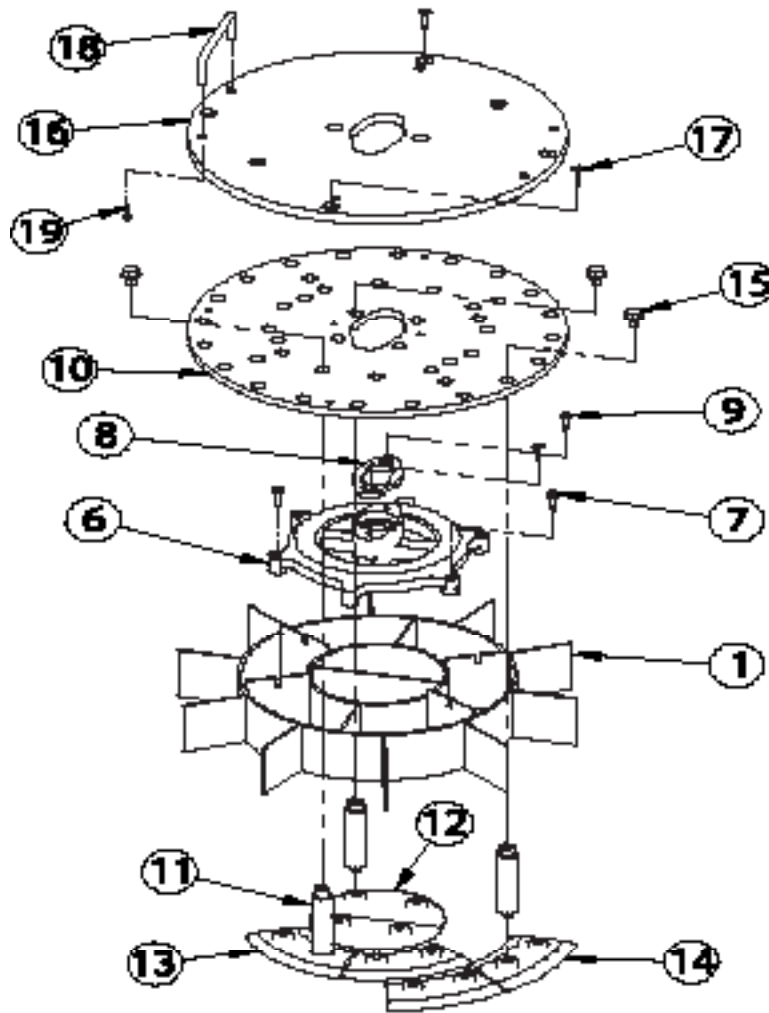

18-PART DIVIDER HEAD ASSEMBLY PARTS

Item	Qty.	Description	Part Number
1	1	18-Part Divider	B4-141-0013
6	1	Divider Plate, 36 & 18 - Part	C4-147-0061
7	4	Fil. Hd. Slotted Mach. Screw	23-E-0406
8	1	Keeper	A4-109-0006
9	2	Flat Head Phillips Mach. Screw	22-E-0405
10	1	Plug Plate, 36 & 18 - Part	B4-147-0063
11	36	Stems for Plug	A4-054-0004
12	2	Inside Plug, 36-Part	A4-139-0012
13	6	Intermediate Plug, 36-Part	A4-139-0013
14	10	Outside Plug, 36-Part	A4-139-0014
15	36	Hex Hd. Washer Type Cap Screw	P4-927-0113
16	1	Cover Plate, 36 & 18 - Part	B4-147-0064
17	6	Flat Hd. Ph. Mach. Screw	22-E-0406
18	2	Handle	P4-939-0010
19	4	Flat Hd. Slotted Mach Screw	22-E-0204
	2	36-Part Dough Pallet (Not Shown)	C4-150-0002

9-PART DIVIDER HEAD ASSEMBLY DRAWING

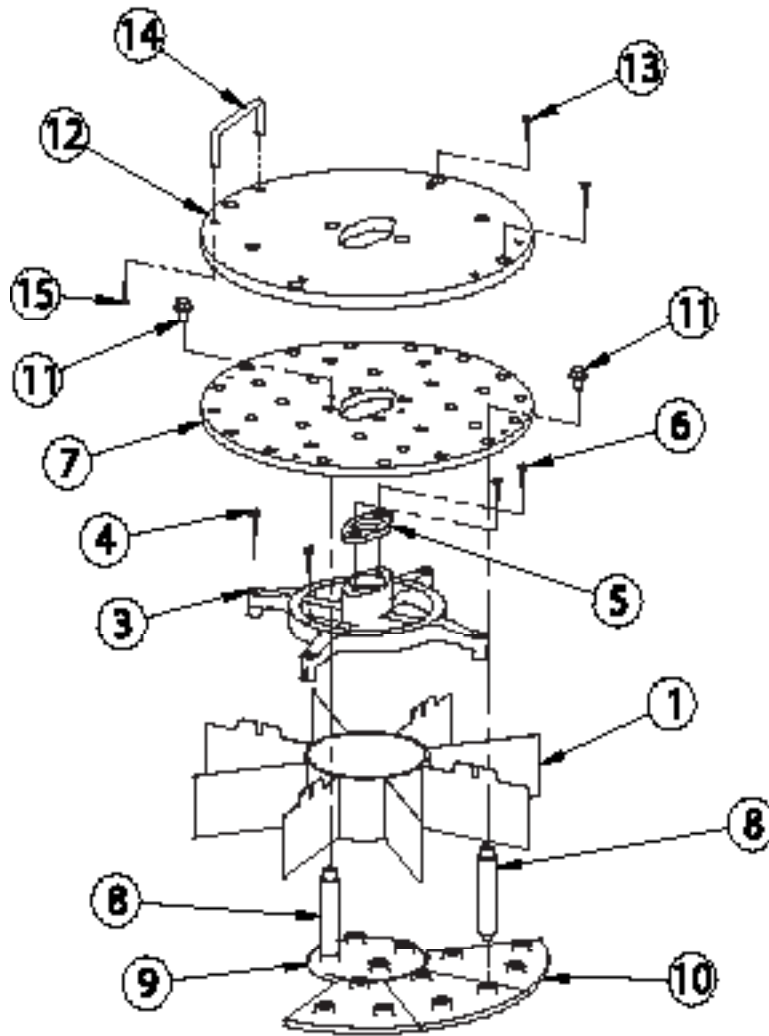

9-PART DIVIDER HEAD ASSEMBLY PARTS

Item	Qty.	Description	Part Number
1	1	9-Part Divider	B4-141-0014
3	1	Divider Plate, 9 - Part	C4-147-0057
4	4	Fil. Hd. Slotted Mach. Screw	23-E-0406
5	1	Keeper	A4-109-0006
6	2	Flat Head Phillips Mach. Screw	22-E-0405
7	1	Plug Plate, 9 - Part	B4-147-0059
8	28	Stems for Plug	A4-054-0004
9	1	Inside Plug, 9 - Part	A4-139-0018
10	8	Outside Plug, 9 - Part	A4-139-0019
11	28	Hex Hd. Washer Type Cap Screw	P4-927-0113
12	1	Cover Plate, 9 - Part	B4-147-0060
13	6	Flat Hd. Ph. Mach. Screw	22-E-0406
14	2	Handle	P4-939-0010
15	4	Flat Hd. Slotted Mach Screw	22-E-0204
	2	9-Part Dough Pallet (Not Shown)	C4-150-0001

6-PART DIVIDER HEAD ASSEMBLY DRAWING

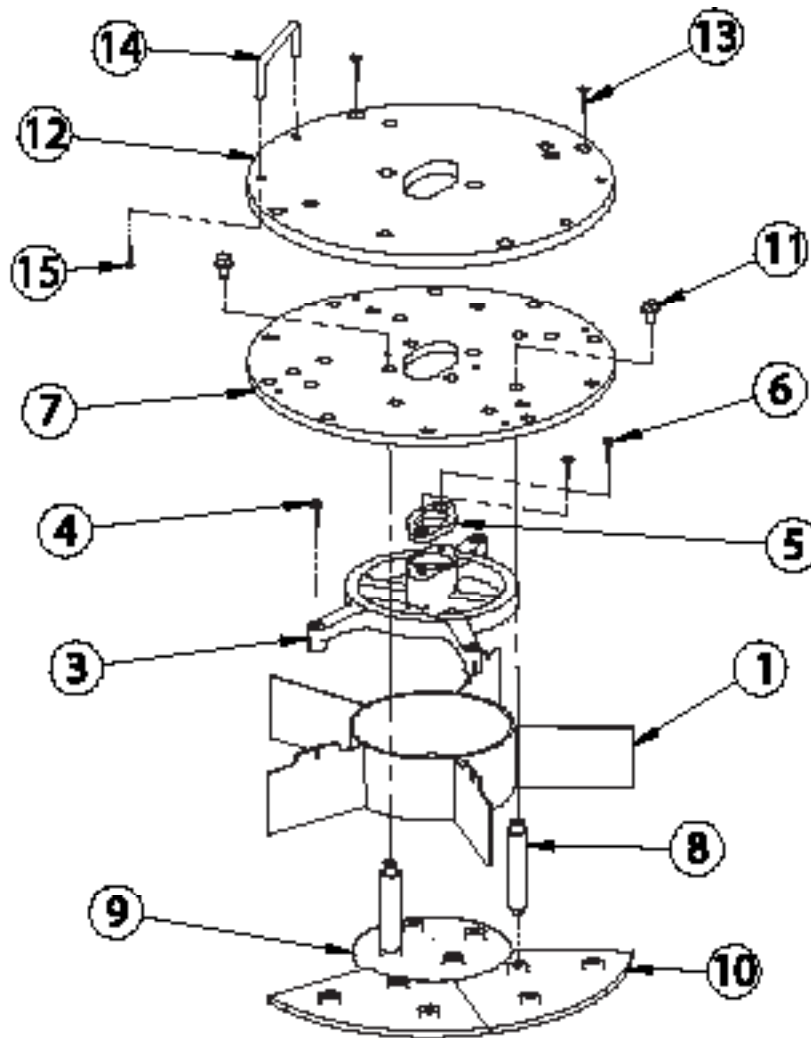

6-PART DIVIDER HEAD ASSEMBLY PARTS

Item	Qty.	Description	Part Number
1	1	6-Part Divider	B4-141-0015
3	1	Divider Plate, 6 - Part	C4-147-0065
4	3	Fil. Hd. Slotted Mach. Screw	23-E-0406
5	1	Keeper	A4-109-0006
6	2	Flat Head Phillips Mach. Screw	22-E-0405
7	1	Plug Plate, 6 - Part	B4-147-0067
8	19	Stems for Plug	A4-054-0004
9	1	Inside Plug, 6 - Part	A4-139-0020
10	5	Outside Plug, 6 - Part	A4-139-0021
11	19	Hex Hd. Washer Type Cap Screw	P4-927-0113
12	1	Cover Plate, 6 - Part	B4-147-0068
13	6	Flat Hd. Ph. Mach. Screw	22-E-0406
14	2	Handle	P4-939-0010
15	4	Flat Hd. Slotted Mach Screw	22-E-0204
	2	6-Part Dough Pallet (Not Shown)	C4-150-0001

3-PHASE ELECTRICAL SCHEMATIC

To be connected to:

208-240V/ 60HZ / 3-Phase - **10 Amp Supply**

- or -

460V / 60 HZ / 3-Phase - **6 Amp Supply**

IF PROTECTED BY FUSES, USE TIME DELAY TYPE

CIRCUIT MUST BE PROTECTED

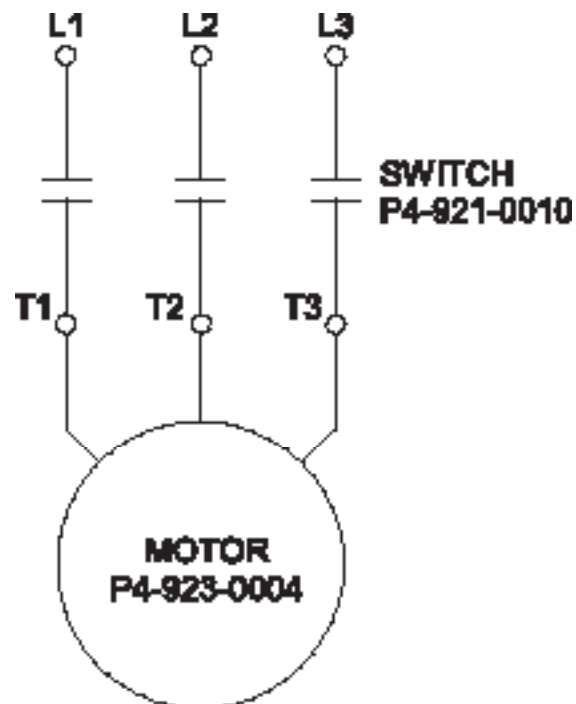

1-PHASE ELECTRICAL SCHEMATIC

120V/ 60HZ / 1-Phase - 15 Amp Supply

IF PROTECTED BY FUSES, USE TIME DELAY TYPE

CIRCUIT MUST BE PROTECTED

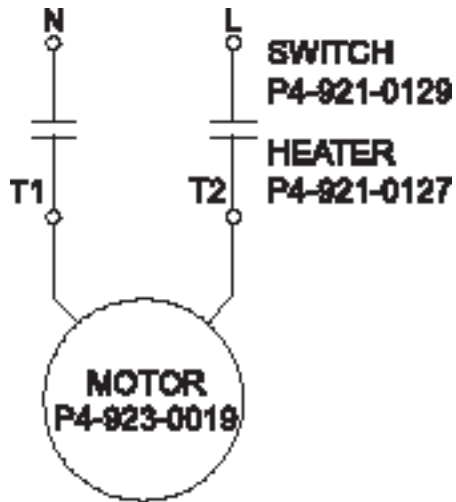

240V/ 60HZ / 1-Phase - 10 Amp Supply

IF PROTECTED BY FUSES, USE TIME DELAY TYPE

CIRCUIT MUST BE PROTECTED

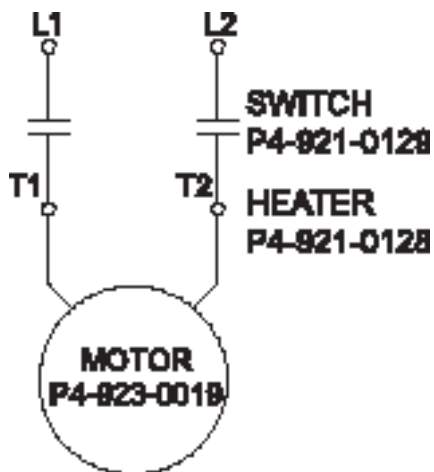

SAFETY LABELS

GOOD SAFETY PRACTICE DICTATES LABELING PROPERLY.
IF YOU REQUIRE MORE LABELS, THE FOLLOWING ARE AVAILABLE FOR
PURCHASE AT A NORMAL PRICE.

	<p>⚠ DANGER</p> <p>HAZARDOUS VOLTAGE Contact will cause electric shock or burn. Turn off and lock out power before servicing.</p>
---	---

	<p>⚠ CAUTION</p> <p>Pinch Point. Keep hands and fingers clear.</p>
--	--

Thank you for choosing the
“Made in the USA”
DoughXpress Model DX-JN
Semi-Auto Dough
Divider/Rounder

Our staff at DoughXpress is dedicated to doing everything possible to reassure you that in making the decision to buy an American Made product you have purchased the highest quality, most dependable divider/rounder available anywhere in the world.

For solutions to product quality and results, just give us a call and our professional Customer Service staff will be glad to assist you.

For your convenience, please contact us on our
Toll Free Customer Service Hotline:
1-800-835-0606 ext. 205

Sincerely,
Your Friends at DoughXpress

WARRANTY

BEFORE warranty repair you MUST get
Prior Authorization: Call 1-800-835-0606
Warranty will be voided otherwise.

WARRANTY & SERVICE

DOUGHXPRESS will automatically register the equipment on the date it was shipped, please keep a copy of their sales invoice showing the serial number and date it was sold/shipped to you with this warranty. We will use the distributor's invoice date as the beginning warranty date. **STAPLE A COPY OF YOUR PROOF OF PURCHASE TO THIS WARRANTY** and keep in a safe place to provide verification of your warranty should a problem occur.

Please fill in the following information and attach a copy of your receipt for your records.

Date Purchased: _____ From: _____
Model #: _____ Serial #: _____

This warranty applies to equipment manufactured by the HIX Corporation (DOUGHXPRESS), Pittsburg, Kansas, U.S.A. DOUGHXPRESS warrants to the original purchaser, the full line of DOUGHXPRESS products against defects in workmanship and material, except for wear and tear for a period of one year parts and labor limited warranty on most items, there are selected items which may carry a two year warranty (refer to owners manual.) All dough press carts, compressors, and accessories are warranted for 90 days from the date of purchase.

Repairs include parts and labor only, excluding is the following:

1. Overtime Labor Rates
2. Expedited Freight for Parts
3. DoughXpress assumes no responsibility for down time or loss of product. All

defective parts must be returned to DOUGHXPRESS for credit. Repairs must be pre-authorized by DOUGHXPRESS prior to work commencing.

4. Travel time is not covered by DOUGHXPRESS, unless pre-authorized by DOUGHX-

PRESS.

In the event of a defect, DOUGHXPRESS, at its option, will repair, replace or substitute the defective item at no cost during this period subject to the limitations of insurance and shipping costs stated below.

This warranty does not cover normal wear and tear, damages due to accident, misuse/abuse, alterations or damage due to neglect, or lack of proper lubrication or maintenance. DOUGHXPRESS shall not be responsible for repairs or alterations made by any person without the prior written authorization by DOUGHXPRESS. This warranty is the sole and exclusive warranty of DOUGHXPRESS and no person, agent, distributor, or dealer of DOUGHXPRESS is authorized to change, amend or modify the terms set forth herein, in whole or in part.

In the case of a problem with the equipment identified herein, DOUGHXPRESS should be contacted during regular business hours to discuss the problem and verify an existing warranty. DOUGHXPRESS personnel will assist the customer to correct any problems which can be corrected through operation or maintenance instructions, simple mechanical adjustments, or replacement of parts. In the event the problem cannot be corrected by phone, and upon the issuance of a return authorization by DOUGHXPRESS, the equipment shall be returned to DOUGHXPRESS or an authorized service representative. All insurance, packaging and shipment/freight costs are solely the responsibility of the customer, and DOUGHXPRESS shall not be responsible for improper handling or damage in transit. DOUGHXPRESS customer service personnel may be contacted for complete return authorization and reconditioning information.

This expressed warranty is given in lieu of any and all other warranties, whether expressed or implied, including but not limited to those of merchantability and fitness for a particular purpose, and constitutes the only warranty made by DOUGHXPRESS.

In no event shall DOUGHXPRESS' liability for breach of warranty extend beyond the obligation to repair or replace the nonconforming goods. DOUGHXPRESS shall not be liable for any other damages, either incidental or consequential, or the action as brought in contract, negligence or otherwise.

This warranty gives you specific legal rights and you may also have other rights which vary from state to state.

1201 E. 27th Terrace • Pittsburg, KS 66762 • U.S.A.
(620) 231-8568 • Fax: (620) 231-1598
E-Mail: mail@hixcorp.com • Website: www.doughxpress.com