

automatic door solutions

Automatic door technology as you've never seen it before!



automatic doors

www.recorddoors.com



record

your global partner for entrance solutions

record automatic sliding doors



Complete Satisfaction and Quality

Our top priority is your complete satisfaction with the quality of our products and services.

By this we mean:

- Individual professional advice in choosing building access solutions for people and goods;
- A wide range of high-tech products to meet the requirements of modern building automation;
- Elegant designs with numerous options, compatible with any architectural style or building plan.

There are 22 record subsidiaries in Europe and the USA, and we have over 50 years' experience in mechanics, sensor technology, electronics and software for automatic door systems and related products.

Talk to us about your needs!

Thank you for your confidence in our company; we look forward to hearing from you.

Our corporate headquarters in Monroe, NC. This state of the art facility allows us to manufacture quality entrances, on time and when you need them. With over 60,000 sq. feet, our facility provides the latest manufacturing techniques and machinery to provide nothing less than your total and complete satisfaction.

www.recorddoors.com



record

your global partner for entrance solutions

5100 Series Sliding Doors

All record-usa Series 5100 automatic sliding entrances allow the sliding doors to break away and swing in the direction of egress when force is applied (similar to a swing door). The doors can be pushed to swing at any point in the door opening or closing cycle (except for Reverse Breakout units), and the force required to break the doors away is mechanically adjustable. On units with exterior swing-out sidelights, breaking the doors away will also cause the sidelights to swing in the same direction as the sliding doors. These units also incorporate mechanical interlocks that lock the sliding doors and sidelights together when the doors are full closed. record-usa utilizes 1 3/4" x 4 1/2" framing for the side jambs and transom members on all sliding entrances. Where applications require, optional 1" x 4 1/2" or 4 1/2" x 4 1/2" framing may be substituted. On telescope, full pocket, and surface mount units, 1 3/4" x 6 1/2" framing is standard with optional 1' x 6 1/2" framing also available. On surface mounted units, 1 3/4" x 2 3/4" (narrow stile) or 1 3/4" x 4 1/4" (medium stile) filler tubes are mounted against the wall or storefront in place of sidelights to provide a weather seal and members to mount the safely beams.

Options

- Electric Locking: Concealed electric locks are available in both fail safe (unlock on loss of power) and fail secure (lock on loss of power) operation. The electric locks are mounted in the header and operate as a carriage lock that automatically locks the door against slide after each open-close cycle, or can be unlocked for daytime use and locked at night.
- Battery Pack: A constant charge battery pack is available for use with building alarm and security systems to ensure that entrances are secured in an emergency. The battery pack can be provided to open or close the door upon loss of incoming electrical power or when signaled from the security system. An UPS (uninterruptible power supply) that provides 300 door opening cycles is also available.
- Exit Devices: Recessed vertical rod exit devices are available on inside slides as well as outside slides. These devices extend across the full width of the door panel. Exit devices are mounted at the same height as the muntin bar (41-5/8" from the floor or threshold to the centerline of the exit device/muntin bar.)
- Partial Open Feature: A selectable partial opening feature is available for applications that require a full width opening during pleasant weather conditions but a partial opening during harsh weather. The microprocessor-based operator control offers an infinite number of partial opening settings. The partial opening can be constant or automatic depending on traffic volume. In the automatic mode during high traffic conditions, the control will override the reduced opening setting and open the door to the full opening available. Once traffic decreases, the control will return to the reduced opening.



S.M.A.R.T. Panel:

- The 5100 introduces a new control panel with an intuitive interface and visual feedback of door status. Selecting the operational mode of the door is a single button press, and the built-in display will provide confirmation.
- The control panel can be manually locked, preventing unauthorized alteration by those who do not have permission to adjust the door.
- Two control panels can be installed on the same door; one at the unit and one remote.
- The control panel will automatically provide an alert message if an abnormal condition occurs.
- Provides user with the phone number of the authorized service agent.
- Reminds you of your commitment in performing a daily safety check.
- Provides information regarding objects in track that may negatively impact the operation of the door.
- Displays current door setting in regard to traffic selection and egress.
- Indicates when a door has been accidentally broken out.
- Identifies if a safety beam has failed or been damaged.
- Notifies user of which part needs replacement due to failure or abuse.



Available in Telescoping & Surface Applied Packages



record sliding door series comply with ANSI 156.10; IBC2003; UL325; CUL and NFPA101.

5100 Series The Greener Door

record-usa's new 5100 series sliding door offers the very latest in automatic door technology to assure the quietest, smoothest performance in a sleek and elegant design. Offering a variable breadth of configurations and functions, the 5100 series assures the architect and building owner a wide array of capabilities in ensuring the most safe, secure and attractive entranceway available by choosing from the following options:

record-usa recognizes the importance of the Green initiative.

Disposing of items that can be recycled diminishes energy, water and natural resources that could be saved by recycling. Creating an environment of cultural responsibility has been a focus of ours over the past several years and will remain as such for the foreseeable future.

Energy Consumption of record-usa 5100 Series sliding door systems:

The Standby load has been tested at 25 watts. This is when the door is closed at rest and set on automatic mode, with other peripherals connected such as sensors, locking, etc.

The maximum loading (continuously in full operation) has been tested at 100 watts. Most leading competitor's average from 250 W to 600 W. This is when the door is under permanent and maximum operation combined with the maximum door leaf weight of 225 pounds per panel. With the motor voltage at 35VDC, the operator is classified as Class II.

Exclusive Traffic Sensitive "Smart" opening logic reduces air infiltration.

When low traffic is sensed the door operates to a selectable reduced opening. When two-way and/or higher volume is sensed, the door operates at full opening width. This is achieved automatically without the requirement of having to go to the door and adjust the operating mode.

By automatically changing the opening and closing width based on pedestrian traffic flow record reduces air loss out of the building.

Construction Waste Management

Product manufactured by record-usa ships in recycled cardboard that is suited for further recycling or for possible reuse when required. We never use hard to dispose of styrofoam like other manufacturers. This eliminates or greatly reduces extensive re-usable garbage/material being delivered to and or buried in public disposal areas.

- Electronics allow for both low wattage consumption and energy efficiency
- Traffic Sensitive Sensor provides controlled and timed opening and closing cycles
- 1" glazing offers protection from the elements and reduces hot/cold transfer from interior and or exterior
- Rubber seals between panels and extended bottom door sweeps reduce and eliminate air and smoke infiltration
- Door closers assure panel coming closed after breakout reducing loss of building heat or cold
- Extended door sweeps add extra resistance to the elements keeping cold air and snow out and heat in thereby saving on heating and air conditioning costs as well

5200 series All Glass

- Clear line of sight unhindered by vertical stiles
- Single slide or bipart packages available
- For use with 1/2" tempered glass

5300 series Heavy Duty

- Virtually silent operation incorporating dual motor operation
- Available for door panels glazed with 1/4" glass up to 10 feet tall; 1/2" and 1" up to 9 feet
- Each door panel may weigh up to 375 pounds

5400 series Impact Rated Hurricane

- Steel reinforced doors and panels
- No lock required on SO panels
- Complies with Dade County NOA 15-0316.04
- Incorporates 7/16" Old Castle Glazing
- LMI series (Large Missile Impact)

5500 Series Non Impact Rated Hurricane

- Steel reinforced doors and panels
- No lock required on SO panels
- Complies with Dade County NOA 15-0316.05
- Incorporates Glazing from 1/4" to 1" (in 1/4" increments)
- Wind load Series

5600 Series

- Choose the 5600 series when desiring to automate wood, hollow metal or other door types and still get the reliability, durability and silence of the 5100 series.

Other Options:

Bullet Resistant Doors:

- Utilizes 1" thick glass laminate UL 753 Level II rated
- Utilizes 7/16" Amortex Composite UL 752 Level III rated (concealed in aluminum extrusions)

www.recorddoors.com



record

your global partner for entrance solutions

5900 Series Manual ICU Doors

Health care environments are challenging in that the need for a door way to rapidly provide break out capability in the event of emergency patient care is always evident.

ICU doors are used to provide separation between patient rooms and other areas of the hospital.

ICU doors are specified to eliminate critical life safety situations arising when possible delays may result due to hospital personnel hesitating momentarily when transporting patients due to slow moving doorways.

record-usa's manual sliding ICU door packages are available in multiple configurations that allow the architect total freedom in the design of a patient facility. One may select from two, three or four panel options, both with or without floor tracks. Other possibilities include either three or six panel telescopic designs, again both with and without floor tracks. To satisfy all of the requirements of the healthcare facility, the doors may be specified to breakaway either into the patient room, or out into the hallway—whichever option best allows for quick and unimpeded transportation of patients either in wheelchairs or on gurneys.

Note: With trackless units, breakaway capability may only be achieved for the sidelite assembly and the active sliding door leaf when the doors reach the fully open position. With standard pin guide track units sidelite and sliding door assemblies breakout from any position during the slide travel of the door.

- PrivacyVue™ Glass
- Integral Blinds
- Self Closing
- Automatic

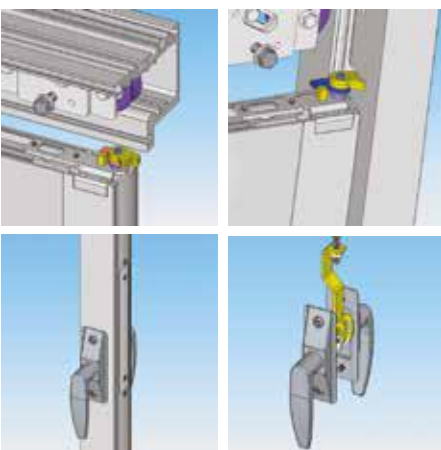

5900 Series Manual ICU Doors Positive Latching

(exclusive design allows for latching at the top on Bi-Parts)

record-usa's unique positive latching system on their manual ICU doors is different from that of the competition in that it latches inside the header and not on exposed vertical members which is quite common.



5800 Series IC Matic Low Energy Power Operated Sliding Doors

Healthcare environments are constantly changing to meet the rigorous demands and expectations of an aging population concerned with the possibility of disease spreading through human contact.

As such, the automatic door market has adapted and recently introduced products to meet these requirements.

The record IC-Matic is a low energy power operation sliding door system ideal for intensive care wards. A sleek design and reduced header height proves attractive while the ability to open automatically through jamb or wall mounted touchless wall plates eliminates the need to physically touch an activation device, thereby reducing greatly the spread of germs.

Unique Positive Latching

Utilizing a fail secure lock with an emergency manual override, the IC Matic positive latching mechanism ensures that the door is securely shut every time the door closes after both the sliding and breakout motions. This allows one to freely exit the room in case of power loss and fire. The IC Matic positive latching mechanism fully complies with UL 1784, NFPA 101 and NFPA 105.

For normal door operation, when it is closed the lock will always be engaged. In order to release this lock under normal operation, simply activate the door using your chosen touchless knowing act activation accessory. The entire locking mechanism is firmly enclosed inside the header; there are no protrusions from the door or jamb tube into the door opening area. The lock throws a rod directly into the factory prepared cutout on the door catch, securely locking the sliding motion of the door.

4900 Series All-in-One Bi-Fold/Bi-Swing Manual Doors



Introducing the new record-usa ALL-IN-ONE door package. Ideally used to eliminate the possible impedance in a hallway of hospital personnel with patients caused by open door leaves, the dual folding-swinging ALL-IN-ONE door system assures that narrow hallways remain clear of possible obstructions that other door — systems may cause.

In the event of an emergency, standard ICU packages may cause concern by breaking into the hallway to allow quick egress from the patient room. Doors of this type also may rely on a floor track system that slows a patient's travel while on a gurney or may lead to discomfort as they proceed over the track. ICU doors are also usually manufactured with hard to grasp handles that are very difficult to open when the nurse may have his/her hands full. Nurses now may easily back into the swing side of the door system and enter the doorway even when handling food trays, patient charts, etc.

When large doorways are desired to allow the simple transportation of carts, wheelchairs or other equipment, standard ICU doors are provided with a breakout feature to allow the door panels to fold in one direction and stack. This design feature provides a larger than normal clear doorway opening than swinging doors may allow. But when choosing record usa's ALL-IN-ONE door package the requirement of a breakaway feature is eliminated simply by opening the bi-fold and biswing door quickly and easily. This ingenious three panel door system offers the combination of both a folding door and a double acting swing door system. Inherent to the creativity of the design is the ability to select which side of the unit the folding door panels are on and which side the swinging door unit is on— whichever allows the quickest egress should an emergency situation arise.

4500 Series Automatic Slide/Fold Doors



Elegant-silent-reliable

Where space is at a premium, record's Slide/Fold door allows quick and easy access. Ideally suited to buildings with narrow entrances, it is the perfect solution for restaurants, hotels, business premises, hospitals and homes for the elderly, as well as offices and private buildings. The Slide/Fold doors use record's proven system drive and control units, and have all the features and functions of record's 5100 series standard operator. The Slide/Fold can be either surface applied or mounted between jambs.

Reasons why the record Slide/Fold is vastly superior to standard folding door systems:

- Provides a much larger door opening in even the most restricted doorways (for example a 78" opening provides a 64.625" clear opening as opposed to a 51" clear opening).
- Eliminates the requirement of finger guard at the jamb — a component that consistently fails



- A folding pivot is subject to torsional loads and fatigue failure caused by —
 - a.) location of the pivot point with respect to the alignment of the panels;
 - b.) flexing (twisting) of the door panels during normal operation;
 - c.) jerky operation of the drive mechanism.
 By aligning the pivot with the door panels, the record design will reduce torsional problems associated with the projected pivot used on the current folding door.
- Moving the pivot closer to the jamb provides additional support of the pivot and increases the clear opening of the door. The record bottom pivot is a sealed, precision bearing mounted into a hardened steel ring, which provides protection for the bearing. Being positioned adjacent to the jamb also increases net door opening and abuse protection.



record

your global partner for entrance solutions

6100 Series (for squared header assemblies please specify 6200 series)

record-usa's 6100 series is the ideal choice for interior door ways that demand reliability, durability and silence. The 6100 was designed to meet all requirements of both ANSI A156.19 for power assist and low energy power operated doors as well as applications that must comply within the parameters as defined by the ADA Civil Rights Law.

8100 Series (for squared header assemblies please specify 8200 series)

The 8100 series as manufactured by record-usa provides the end user with the best solution for interior or exterior entrances. Since the 8100 has complete control of the door throughout its entire opening AND closing cycle and may be programmed for either ANSI A 156.19 or ANSI A 156.10 (power operated pedestrian doors) applications, the 8100 promises to be your choice for heavily used doorways that require a long lasting unit. The 8100 retains the completely silent performance of the 6100 series as well.

8600 Series

The record 8600 overhead concealed package incorporates the 8100 series operator but is supplied complete with a medium stile, center pivoted aluminum door panel, standard 1 3/4" X 4 1/2" jamba, cylinder and lock; push bar; offset-pull handle; finger guards and threshold (wide stiles also available.)

8700 Series

When the requirement of an overhead concealed unit that can be used on offset or butt hinge applications is evident, the record-usa 8700 series provides attractive aesthetics as well as durable performance. The 8700 series is supplied with a continuous hinge gear only.



	6100 Series	8100 Series
Doors	Interior	Interior/Exterior
Weights	up to 175 lbs.	up to 350 lbs.*
ANSI	156.19	156.19/156.10
Arm	Standard	Standard/Track/Offset
Door Size	36" or 72"	up to 51" Single & 108" Pairs
Warranty	1 Year	2 Year
Non Handed	✓	✓
Overhead Concealed	✓	✓
Inswing Doors	✓	✓
Outswing Doors	✓	✓
Double Egress	✓	✓
On/Off/Hold Open Switch	✓	✓
Microprocessor Control	✓	✓
Surface Applied	✓	✓
Center Hung	✓	✓
Center Pivoted doors Butt/Offset Hung Doors	✓	✓
Deep Reveal Applications	✓	✓
ADA Compliance	✓	✓
Fire Rated Openings	✓	✓
Standard Anodized	✓	✓
Paint	✓	✓
Clad	✓	✓
Electromechanical	✓	✓
Push to Start	✓	✓
Power Boost (Latch Assist)	✓	✓
No Relay Required for Electric Strikes	✓	✓
No Lockout Relay Required for Sensors	✓	✓
Built-in Power Supply for Sensors	✓	✓
Built in Power Supply for Sensors	✓	✓
Optional Remote Digital Control Panel	✓	✓

Features/Options:

- Available with either squared headers or rounded headers
- Brake option available to maintain door position at the full open and/or full closed position(s) on the 8100 Series
- Reveals up to 24" in depth
- Extended arm adaptors to provide clearance in multiple framing conditions
- UL listed for both UL325 and UL228
- Non-handing operator assembly
- Easily configurable with the record-usa S.M.A.R.T panel
- One header for simultaneous, independent and double egress pairs
- Can be prepped for automation on one door leaf and used with manual closers by LCN, Jackson, Ryobi, etc. on the other
- Two year warranty is standard on the 8100 Series
- Overhead design (see the 8600 Series on the next page) provides completely concealed application
- Non handed to maximize all field condition applications
- The 8100 is adjustable from low energy to high speed operation to meet application needs and ANSI code requirements
- Unit is capable of either push or pull operation with either standard or track arm configuration
- The 8100 is able to confidently and safely operate door
- leaves up to 350 pounds* and 48". The 6100 series may be selected for doors up to 48" and weighing up to 175 pounds.
- Built in interface for electric locking eliminates the need for additional costly peripherals
- Push to start operation saves on the installation and expense of additional activation devices
- Latch assist closing ensures closing to overcome stack and wind conditions (saves heating and/or air conditioning expense) or to overcome applied door hardware such as electric strikes that may otherwise bind, causing a breach of security
- Obstruction shut down halts the door when an object is detected to provide additional safety throughout the door operation
- Recycle on obstruction reopens the door upon making contact with an object or individual to provide additional safety throughout the door operation
- Built in lock out relay provides simplified coordination with safety devices

*Consult Factory



In the Floor
Sliders



In the Floor
Swingers



High Speed
Roll-Up Doors



Thermally
Broken Doors



Exit Lane
Breach Control



Security
Portals

→ record USA

4324 Phil Hargett Court – Post Office Box 3099 – Monroe, NC 2811
tel. +1 704 289-9212 – e-mail: info@recorddoors.com – www.recorddoors.com

→ Headquarters

agta record ltd – Allmendstrasse 24 – 8320 Fehrltorf – Switzerland
tel.: +41 44 954 91 91 – e-mail: info@agta-record.com – www.agta-record.com

www.recorddoors.com



record

your global partner for entrance solutions