

# AM SERIES DOCK LEVELER

M E C H A N I C A L S P E C I F I C A T I O N S



## Design Highlights

- Patented SafeTFrame™ Design
- Single Adjustment Point Extension Spring Counterbalance
- Unlimited Float Hold down
- Automatic Lip Extension
- High Tensile Steel Lip, Deck & Beams
- Open Subframe Design
- Structural Steel Safety Legs
- Working Range Toe Guards
- Below-dock Endloading Capability
- 16" Lip Standard (406 mm)
- Integral Maintenance Strut & Lip Support Latch
- Heavy-duty B410-14F Dock Bumpers
- Reduce Lip Crown/Extended Lip Chamfer

## Project Information

Job Name \_\_\_\_\_

Address \_\_\_\_\_

General Contractor \_\_\_\_\_

Distributor \_\_\_\_\_

Model \_\_\_\_\_ Quantity \_\_\_\_\_

## Certified For Construction

By \_\_\_\_\_

Company \_\_\_\_\_

Address \_\_\_\_\_

Date \_\_\_\_\_

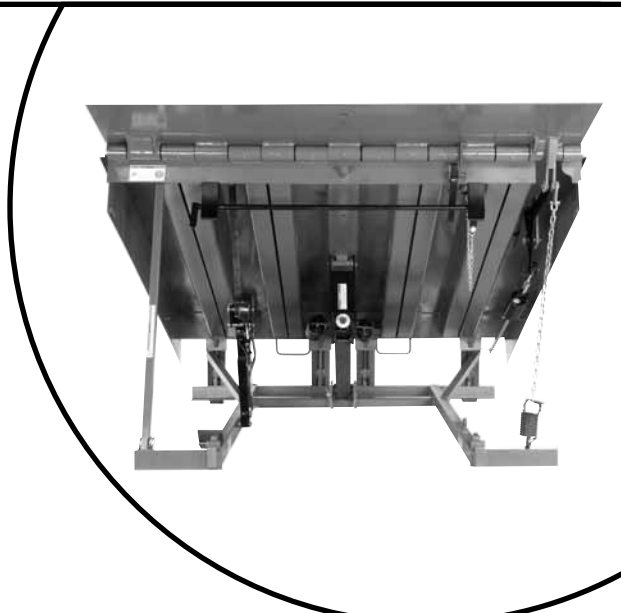

## Available Options

- Factory Installed Brush Weatherseal
- Factory Installed Neoprene Weatherseal
- ENERGY GUARD® Perimeter Weatherseal System
- 18" Lip (457 mm)
- 20" Lip (508 mm)
- 24" Pit Conversion (610 mm)
- Spray Foam Insulated Deck
- Galvanized Finish (Deck, Lip & Subframe Only) (40k only)
- Full Operating Range Toe Guards
- Lip Taper \_\_\_\_\_ (specify)
- High Lip Crown
- Pan Option:
  - For installation without pre-formed concrete pits, dock leveler supplied with integral pre-formed steel pan for pour-in-place construction. Dock leveler shall be in an enclosed steel pan structure complete with its own six-piece welded structural curb angles and concrete anchors. The dock leveler is to be concreted in place as the floor is poured.
- Other \_\_\_\_\_



**Pan Option**

## Accessories

- STAR® Vehicle Restraint \_\_\_\_\_
- HIDDEN HOOK™ Recessed Restraint
- MANUAL SURFACE CHOCK Wheel Restraint
- SURFACE CHOCK™ Wheel Restraint
- AUTO CHOCK® Wheel Restraint

## Bumper Options

- B410-14       VB420-11F
- B610-14       VB420-11 Steel Faced
- B610-14F     Other \_\_\_\_\_

## Capacity

- 30K lb    35K lb    40K lb    45K lb
- (13.6K kg)   (15.8K kg)   (18K kg)   (20.4K kg)

# CM SERIES DOCK LEVELER MECHANICAL SPECIFICATIONS



**1. General:** "CM" Series hinged lip dock leveler with extension spring counterbalance assembly. Unit conforms to ANSI/MH14.1-1987 performance requirements. Unit to be manufactured by Kelley.

**2. Construction, Platform Assembly:** Platform constructed of high tensile steel safety tread deck plate supported by unique L-beam construction (30K-35K lb.) (13.6K-15K kg), split box beam construction (40K & 45K lb) (18K & 20.4K kg). Structural members fully welded to front header. Deck to be ¼" (6 mm) thick.

**3. Lip Assembly:** Lip to be 16" (406 mm) high tensile steel safety tread lip plate with beveled leading edge. Lip to be ⅝" (16 mm) thick on 30K - 45K lb. (13.6K-20.4K kg) capacity units. 7' (2.13 m) wide lip tapers to 6'-6" (2.01 m) at leading edge (6'-0" (1.83m) taper optional). Lip hinge to have full width structural front header and heavy wall tubing with a minimum of ⅝" (8 mm) wall thickness on 30K & 35K lb. (13.6K & 15.8K kg) capacities, ½" (13 mm) wall thickness on 40K & 45K lb. (18K & 20.4K kg) capacities. Hinge tubes to have gussets on 35K & 45K lb. (15.8K & 20.4K kg) capacity. Lip hinge shaft to be a minimum of 1" (25 mm) solid steel on 30K-35K lb. (13.6K-15.8K kg), 1-¼" (32 mm) solid steel on 40K & 45K lb. (18K & 20.4K kg).

**4. Lip Extension:** Lip assist mechanism provides gentle lip activation and reduced walk-down loads.

**5. Rear Subframe & Hinge:** Rear structural frame consists of a welded structure constructed from 4 structural angle vertical members connecting two horizontal members. The upper rear angle has longitudinal support gussets & additional deck supports to promote structural stiffness. The hinge system consists of four ¾" (19 mm) thick lugs allowing 4 inches (100 mm) of side to side deck twist.

**6. SafeTFrame™:** Adjustable shim system consisting of four independently operated leveling feet capable of 1-½ inches (38 mm) of vertical adjustment each. System eliminates the need for installer to place and weld steel shim stock under the vertical uprights providing more consistent installation thus preventing a gap or (bump) between the rear transition angle and curb angle.

**7. Counterbalance:** Oil-tempered chromium silicon steel extension spring counterbalance with single adjustment point for high strength, durability, and easy walk-down.

**8. Product Finish:** Enamel green finish.

**9. Open Subframe Design:** Unique design allows access for easy pit clean out and routine maintenance.

**10. "Nite-Lock":** Permanent "Nite-Lock" to prevent unauthorized entry beneath locked overhead door is standard.

**11. Structural Center Deck Support:** Standard center beam support (5" (127 mm) structural channel) to reinforce leveler for 3-wheel lift truck traffic on 40-45K lb. (18K-20.4K kg) capacities only.

**12. Toe Guard Protection:** Working range toe guard protection is provided on both sides of the leveler. Yellow OSHA required markings IAW ANSI Z535.1 provided on the sides of the dock leveler.

**13. Safety Legs:** Structural safety legs provide emergency support should a truck depart with a load on the leveler platform. Design incorporates cam mechanism to limit interference from truck float.

**14. Integral Maintenance Strut & Lip Support Latch:** A permanently mounted, hinged, lockout capable maintenance strut and lip support latch are provided to support the lip and leveler during routine maintenance and pit cleaning.

**15. Below-dock Control (Endloading):** Front mounted lanyard facilitates below-dock endloading.

**16. Out of Level Compensation:** Leveler platform is designed to compensate for canted truck beds up to 4" (100 mm) and rear edge remains flush with the pit to eliminate pinch points.

**17. Float Compensation:** Allows for vertical carrier deflection when lip is in contact with truck bed.

**18. Operation:** Kelley's "CM" mechanical leveler shall be supplied completely assembled with platform and lip mechanism and ready for use. Leveler to be operated by pulling release ring at rear of ramp; unit will raise, and lip will extend and hold. No manual lifting required. Unit shall be powered by extension springs with a single adjustment point. Operator to walk ramp down to truck bed. Unlimited float holddown shall hold unit in position. Unit will float with truck movement. Working range to be 12" (305 mm) above-dock and 12" (305 mm) below-dock for 6' (1.83 m) and 8' (2.44 m) long units, 18" (457 mm) above-dock and 12" (305 mm) below-dock for 10' (3.05 m) long units. The lip extends a minimum of 11" (279 mm) beyond the face of a 4" (100 mm) bumper. After loading/unloading is complete, operator pulls and holds release chain until lip clears the truck bed. As leveler raises, lip will extend in a smooth, controlled manner. In stored position, ramp is fully supported by lip keepers.

**19. Installation:** Unit shipped completely assembled and ready for installation in pre-formed concrete pit. Pit depth is 20" (508 mm) for 6' (1.83 m) and 8' (2.44 m) long units, 24" (610 mm) for 10' (3.05 m) long units. Pit construction to be in accordance with certified Kelley pit detail drawings. Contact Kelley for current cost and nearest distributor.

**20. Limited Warranty:** Limited parts & labor warranty on all components under normal use for a 1-year "Base Warranty Period" beginning on the completion of installation or the sixtieth (60th) day after shipment, whichever is earlier. Additional limited 4-year parts only warranty on main springs. Limited prorated 10-year structural warranty available upon engineering approval of written application.

**21. Bumpers:** Unit to include two model B410-14F (4" (100 mm) Thick x 14" (356 mm) W x 10" (254 mm) H) heavy-duty bumpers.

## NOMINAL DIMENSIONS

MODEL	WIDTH	LENGTH
CM6X6	6' (1.83 m)	6' (1.83 m)
CM6.5X6	6'6" (2.01 m)	6' (1.83 m)
CM7X6	7' (2.13 m)	6' (1.83 m)
CM6X8	6' (1.83 m)	8' (2.44 m)
CM6.5X8	6'6" (2.01 m)	8' (2.44 m)
CM7X8	7' (2.13 m)	8' (2.44 m)
CM6X10	6' (1.83 m)	10' (3.05 m)
CM6.5X10	6'6" (2.01 m)	10' (3.05 m)
CM7X10	7' (2.13 m)	10' (3.05 m)

