

The image features a large, green, industrial-grade dock leveler mounted on a dark green wall. The leveler has a black top cover with the 'KELLEY' logo. The background is a dark green wall with a repeating pattern of stylized, light-colored bird-like shapes. The overall aesthetic is industrial and professional.

**KELLEY**

## KELLEY Specialty Dock Levelers

KELLEY Specialty Dock Levelers provide unique solutions to various loading dock application challenges. Whether you need a custom dock leveler system for cold storage operations, a heavy-duty dock leveler for high volume, heavy capacity loads, or a truly unique device to service extra wide trailers below dock, Kelley has a tailored solution to meet your specific needs.

# KELLEY VERTICAL STORING DOCK LEVELER

The biggest challenge for companies in the food, beverage and pharmaceutical industries as well as a growing number of other operations, is sustaining a clean, energy efficient warehouse environment. That's why thousands count on Kelley vertical storing dock levelers for unequalled environmental control along with safe, secure performance.



- ① Unique hinged bottom draft pad maintains environmental control
- ② Standard 20" (508 mm) lip. 16" (406 mm) or 18" (457 mm) lip optional
- ③ Power-in/power-out lip cylinder provides superior operational control and less maintenance compared to conventional "gravity-fall" systems
- ④ Dual-acting main cylinder hydraulic system provides leveler with controlled power up and power down performance
- ⑤ Run-off guards on the deck assembly prevent fork lifts from driving off the side of the leveler
- ⑥ Structural channel beams and high tensile steel safety tread plate. Structural members are fully welded to the front and rear header assemblies
- ⑦ Maintenance locking bar with lockout pin prevents use while maintenance or cleaning is in process
- ⑧ No leveler structure attached to pit floor for easy cleaning. All hinge points minimum 2" (51 mm) off floor
- ⑨ Rear embed channel with 5 factory-welded hinges

The Kelley Hydraulic Rail Leveler is designed specifically for rail operations to provide easy access to rail cars and more efficient loading and unloading. Rail levelers are mounted to a track assembly to allow them to move laterally in either direction and can be equipped with a manual or hydraulic side shift for efficient and precise positioning into the rail car.

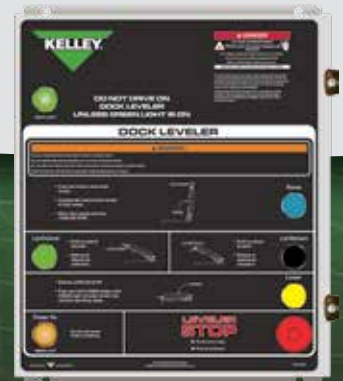

Kelley's control panel features individual controls for all dock leveler functions, including a standard mushroom stop and can be interlocked with other equipment through a Master Control Panel.



Even during loading and unloading, Kelley's patented hinged bottom pad limits air infiltration and energy loss. When leveler is within 18" (457 mm) of the truck bed, the platform will automatically free float with the trailer to avoid possible damage to material handling equipment.



Vertical storing dock levelers work with insulated doors to prevent energy loss by allowing the door to be closed flush to the floor while also maintaining security.

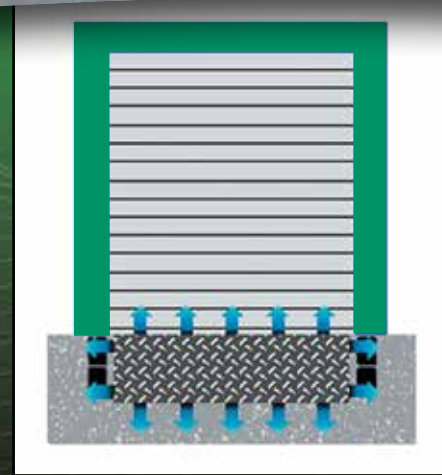

Conventional pit-style dock levelers allow air to flow through the gaps around the unit reducing energy efficiency and increasing the threat of spoilage.



The leveler is stored vertically, providing a tight seal around the doorway. Vertical leveler applications can also be tailored to allow trailer doors to swing open into the building to further prevent product spoilage or theft.



# KELLEY HYDRAULIC HEAVY CAPACITY DOCK LEVELER

Kelley's HHC Series Dock Levelers are ideal for the paper, auto and steel industries or any applications moving a large volume of heavy loads. These heavy capacity levelers integrate all the standard features that Kelley hydraulic levelers are known for and their rugged design allows them to handle even the toughest loads.

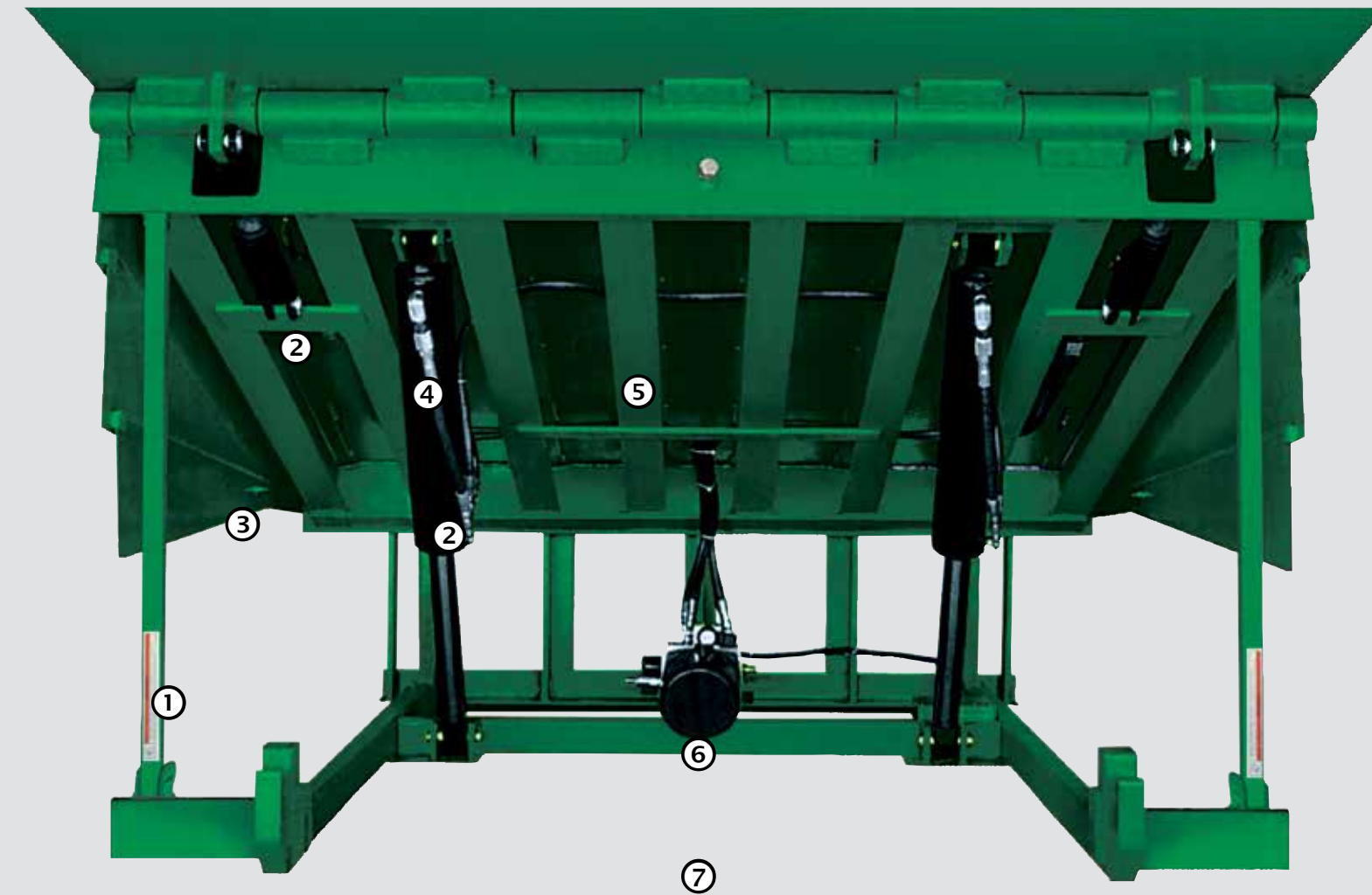

- ① Dual integral support struts
- ② Hydraulic main and lip extension cylinder on 60,000 lbs (27,215 Kg) capacity models and dual hydraulic main and power-in/power-out lip extension cylinders on 80,000 lbs (36,287 Kg) capacity models
- ③ Full operating range toe guards
- ④ Safety velocity fuse for free fall protection
- ⑤ Heavy-duty I-beam construction
- ⑥ Regenerative hydraulics
- ⑦ Open frame design for easy pit clean out and maintenance
- ⑧ Standard 18" (457 mm) lip, 20" (508 mm) lip optional

# KELLEY SAFETY BARRIER LIP

Kelley Heavy Capacity Dock Levelers can be equipped with an optional Safety Barrier Lip that provides a full-time 5" (127 mm) solid steel vertical barrier to prevent accidental fork lift roll-off.



*In the stored position, the leveler lip extends above the deck providing a full-time steel barrier, while in the extended position, the lip remains flush with the leveler deck. The Safety Barrier Lip is designed to be one of the strongest in the industry, capable of stopping a 15,000 lbs (6,803 Kg) load at 5 mph (8.05 Km).*

*In a below loading dock application, the Safety Barrier Lips prevents fork lift's front wheels from accidentally rolling off the leveler.*



Standard single-button control panel.

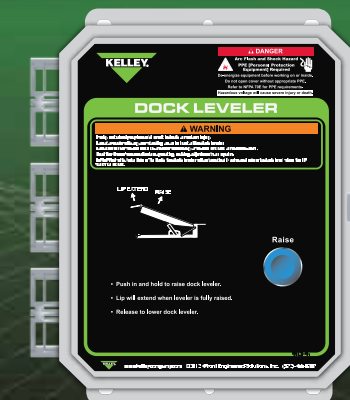

Optional single-button control panel can be interlocked with other equipment for added safety.



Optional full-control control panel features independent lip extend and mushroom-style stop buttons and can be interlocked with other equipment for added safety.

# KELLEY VERSADOCK™ DOCK LEVELER

Kelley's VERSADOCK Dock Leveler is a versatile design that can function as a conventional dock leveler while also providing the adaptability to handle high cube (low boy) trailers at a single dock position.

- ① Dual integral support struts
- ② Powered in and out lip extension control
- ③ Full operating range toe guards
- ④ Dual hydraulic main and power-in/power-out lip extension cylinders on 60,000 lbs (27,215 Kg) and 80,000 lbs (36,287 Kg) capacity models
- ⑤ Heavy-duty I-beam construction
- ⑥ Regenerative hydraulics
- ⑦ Open frame design for easy pit clean out and maintenance
- ⑧ Integral steel faced bumpers
- ⑨ 12" (304 mm) above dock and up to 18" (457 mm) below dock service range depending on leveler length
- ⑩ Standard 18" (457 mm) lip, 20" (508 mm) lip optional

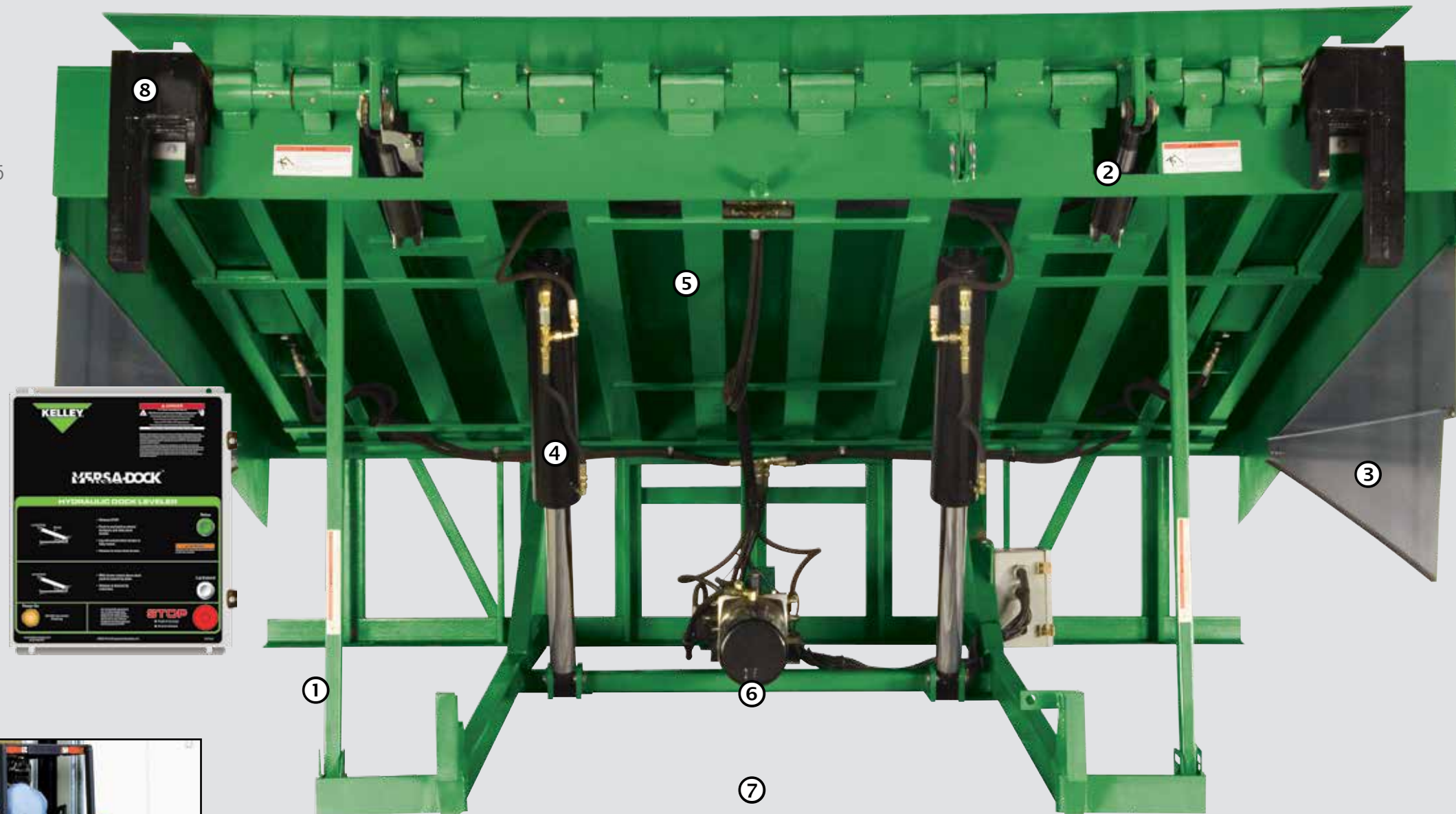

The VERSADOCK control panel features individual controls for all leveler functions and includes a mushroom-style stop for increased safety.



The Kelley VERSADOCK leveler provides 9' (2.74 m) wide unobstructed access for extra-wide below dock loads.



Standard 6' (1.83 m) or 7' (2.14 m) wide levelers can make extra-wide loads hard to load and unload, often resulting in product damage.



Integrated Steel Faced Vertical Bumpers position automatically to provide maximum protection against vehicle damage to the leveler, walls, restraints and product.

# INTEGRATE YOUR KELLEY EQUIPMENT FOR SAFER, MORE EFFICIENT AND PRODUCTIVE DOCKS.

KELLEY speciality dock levelers can be integrated with other loading dock equipment, including vehicle restraints, dock doors, inflatable seals or shelters, dock lights and security systems to improve productivity, security and environmental control. Kelley's Master Control Panel dramatically increases safety and operational efficiency by integrating and interlocking equipment controls, ensuring that equipment is always used in proper sequence.



## EXPERIENCE OUR ENGINEERED SOLUTIONS FOR YOURSELF



For nearly 60 years, Kelley has been designing, manufacturing and integrating loading dock equipment. We invite you to visit our showroom, located in Dallas, TX, which features a variety of the latest loading dock and warehouse solutions. Our Visit-in-Person (VIP) program offers a unique opportunity to gain hands-on experience with our products and interact with engineering and manufacturing personnel in a comfortable environment.

**CAN'T MAKE THE TRIP TO DALLAS?** Let our Mobile Showroom come to you. Our 53' completely enclosed and temperature controlled trailer features over 20 full-sized, fully-functional dock equipment demo units. Call 1-877-778-DOCK (3625) to schedule an appointment and we'll drive our loading dock solutions straight to your door.



**KELLEY**<sup>®</sup>

1612 Hutton Dr., Suite 140  
Carrollton, TX 75006

Tel: 800.558.6960  
Fax: 972.389.4766

email: [sales@kelleycompany.com](mailto:sales@kelleycompany.com)  
[www.kelleycompany.com](http://www.kelleycompany.com)



A continuing research program is in effect at Kelley. We reserve the right to incorporate product improvement at any time without prior notice.