

Brass Lever Gate Valve (Fig. 1)

Part No.	Description
40019A	3" (76 mm) with handle
40019B	4" (101 mm) with handle
40019H	6" (152 mm) with handle



Valve Handle (Fig. 2)

Part No.	Description
40019C	Handle for 3" (76 mm) valve
40019E	Handle for 4" (101 mm) valve
40019L	Handle for 6" (152 mm) valve

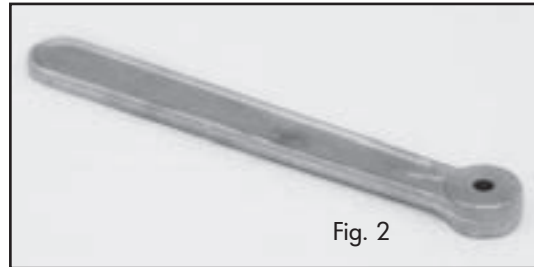

Brass Ball Valve

Part No.	Description
1150135	1/4" (6.3 mm) valve
1150136	1/2" (12.7 mm) valve
1150137	3/4" (19.05 mm) valve
1150138	1" (25.4 mm) valve
1150689	1-1/4" (31.75 mm) valve
47063D	1-1/2" (38.1 mm) valve
1150140	2" (51 mm) valve
1150238	2-1/2" (63.5 mm) valve
1150141	3" (76 mm) valve
1150239	4" (101 mm) valve
1201605	1-1/4" (31.75 mm) 3-way valve
150453	1" (25.4 mm) 3-way valve



Butterfly Valve (Air-Actuated)

Part No.	Description
1150682	2-1/2" (63.5 mm) valve
1151109	3" (76 mm) valve
1151097	4" (101 mm) valve
1151102	5" (127 mm) valve
1151063A	6" (152 mm) valve
1151098	8" (203 mm) valve
1150420	10" (254 mm) valve
1150576	12" (305 mm) valve



Actuator

For air-actuated butterfly valve.

Part No.	Description
1151110	For 3" (76 mm) valve (1151109)
1151099	For 4" (101 mm) valve (1151097)
1151103	For 5" (127 mm) valve (1151102)
1151101	For 6" (152 mm) valve (1151063A)
1151100	For 8" (203 mm) valve (1151098)

Valve Seal Kit

For air-actuated butterfly valve.

Part No.	Description
1651948	For 4" (101 mm) valve (1151097)
1651962	For 5" (127 mm) valve (1151102)
1651956	For 6" (152 mm) valve (1151063A)
1651953	For 8" (203 mm) valve (1151098)

Disc Seal Kit

For air-actuated butterfly valve.

Part No.	Description
1651947	For 4" (101 mm) valve (1151097)
1651960	For 5" (127 mm) valve (1151102)
1651959	For 6" (152 mm) valve (1151063A)
1651952	For 8" (203 mm) valve (1151098)

Valve Body Assembly

For air-actuated butterfly valve.

Part No.	Description
20861A	For 4" (101 mm) valve (1151097)
20980	For 5" (127 mm) valve (1151102)
20980B	For 6" (152 mm) valve (1151063A)
1152079	For 8" (203 mm) valve (1151098)

Butterfly Valve (Manual)

Part No.	Description
1151111	3" (76 mm) valve
1151104	Handle for 3" (76 mm) valve
20861A	4" (101 mm) valve
44676	Handle for 4" (101 mm) valve (Fig. 1)
20980B	6" (152 mm) valve
44730B	Handle for 6" (152 mm) valve
1150134	8" (203 mm) valve
1150656	10" (254 mm) valve
1150722	12" (305 mm) valve



Fig. 1

Knifegate Valve

Manual carbon steel valve.

Part No.	Description
1150524	4" (101 mm), flange to flange
1150525	6" (152 mm), flange to flange
1150429	4" (101 mm), flange to male pipe threads
1150430	6" (152 mm), flange to male pipe threads
1150430A	6" (152 mm), TTMA flange



Knifegate Valve (Air-Actuated)

Part No.	Description
1150974	4" (101 mm) valve
1150571	6" (152 mm) valve
1150460	8" (203 mm) valve
1150311	10" (254 mm) valve



Knifegate Valve (Manual)

Part No.	Description
1150774	3" (76 mm), hand wheel actuated
1150204	4" (101 mm), hand wheel actuated
1150145	6" (152 mm), hand wheel actuated
1150326	8" (203 mm) valve
1150146	10" (254 mm), hand wheel actuated
48257	4" (101 mm) TTMA flangw
46347	10" (254 mm), knife valve Dzurik KNF
1150550A	8" (203 mm) Valve seat kit

Dezurik Valve (Fig. 1)

Part No.	Description
1150544E	12" (305 mm) valve, KGC series
1150544	16" (406 mm) valve, knifegate

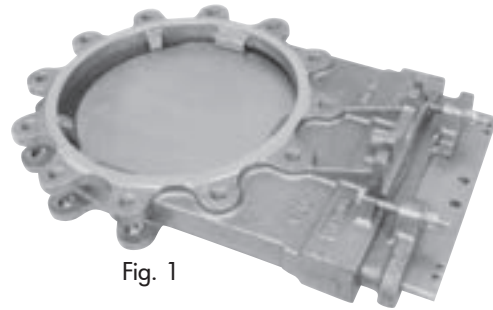

Fig. 1

Dezurik Valve Blade (Fig. 2)

Part No.	Description
1150747	12" (305 mm) blade
1150529	16" (406 mm) blade



Fig. 2

Dezurik Valve Packing (Fig. 3)

Part No.	Description
1250120	3/4" (19.05 mm) packing for liquid ring pump
1250329	1/2" (12.7 mm) Teflon® packing



Fig. 3

Dezurik Valve Seats

Part No.	Description
1150544F	For 12" (305 mm) valve, KGC series
1150589	Viton® for 12" (305 mm) valve (Fig. 4)
1150654	Viton® stainless steel for 12" (305 mm) valve
1150733	Viton® stainless steel for 12" (305 mm) valve
1151081	High-temp for 12" (305 mm) valve
1151092	For 12" (305 mm) valve, KGL series (Fig. 5)
1250335	For 12" (305 mm) valve, plastic .54" x 11.88" OD x 10.63" ID (13.7 mm x 301.7 mm x 270 mm) (Fig. 6)
1250124	O-ring type for 16" (406 mm) valve
1250343	For 16" (406 mm) valve, Teflon® .515" x 15.595" OD x 13.75" ID (13.1 mm x 396.1 mm x 349 mm)



Fig. 4



Fig. 5



Fig. 6

Kunkle valves are essential to maintain the proper vacuum rating for your specific blower and protecting against overheating. Pressure relief valves are essential to properly maintain the safe working pressure of your vacuum unit.

Kunkle Valve

Part No.	Description
42633	3" (76 mm) vacuum relief valve — preset at 15" Hg (381 mm/Hg) (Fig. 1)
1350982	3" (76 mm) valve preset at 18" (457 mm)
1140263	3" (76 mm) pressure relief valve preset at 14.5 psi (.99 bar)
1140064	2" (51 mm) pressure relief valve (Fig. 2)



Fig. 1



Fig. 2

Safety Screen Basket

Part No.	Description
1150147	3" (76 mm) for vacuum relief valve
1150148	4" (101 mm) for vacuum relief valve
1150547	6" (152 mm) for vacuum relief valve
1150247	8" (203 mm) for vacuum relief valve
1150850	10" (254 mm) for vacuum relief valve



Directional Control Valve

Part No.	Description
1140265	Pneumatic directional control valve

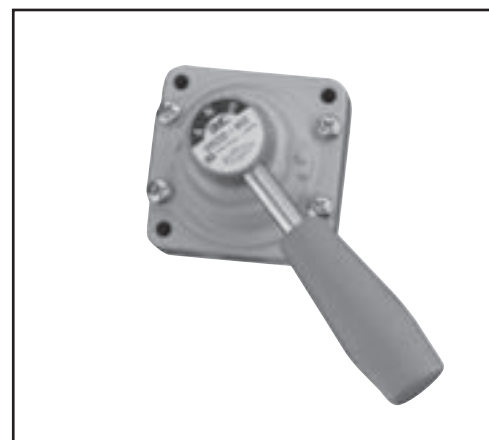

Air Fitting Manifold

Part No.	Description
1140465	Used on NX units

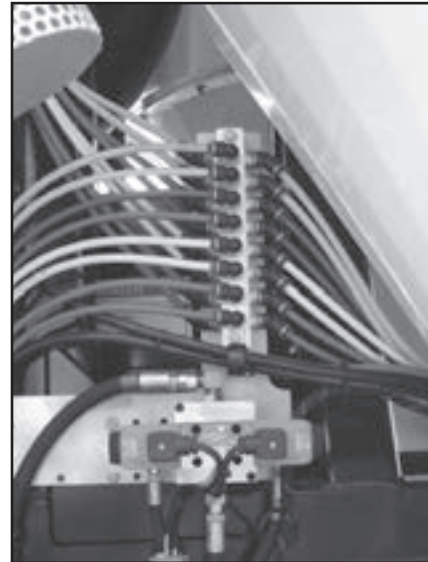

Air Filter

Part No.	Description
1140458	1/2" (12.7 mm) NPT — used on NX units

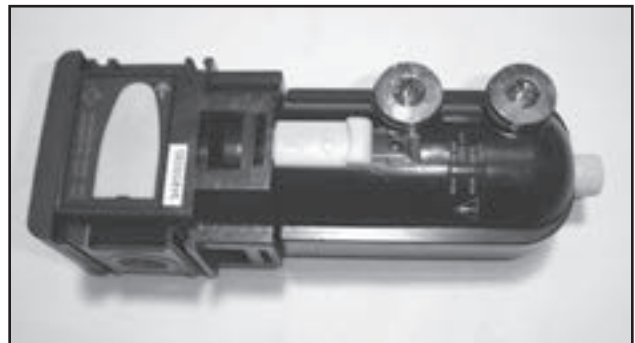

TECH TIP: Proper air filter maintenance is critical for component operation. Condensation during the compression of air and water vapor can cause contaminants in the lines. These particles need to be removed before they reach the pneumatic equipment, such as valves and cylinders. Particles can damage and clog small orifices in the equipment unless they are filtered out. Filters separate the water droplets and particles from the air before they reach your pneumatic equipment.

Air Valve

Used to engage and disengage fluidizing nozzles on NX baghouses.

Part No.	Description
1140460	2-way air valve

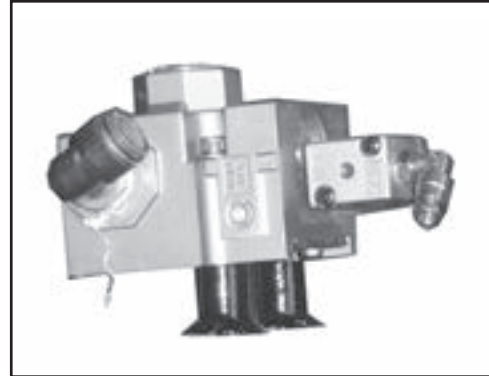

Air Shifter

Part No.	Description
1140074	With one supply 1 delivery for PTO
1140048	With one supply 2 delivery for TC

