

**Dana Driveline Assembly**

Part No.	Description
1350021	Driveline assembly
44665	Flanged yoke (Fig. 1)
43961	U-joint (Fig. 2)
1210003	Slip yoke
1210002	Yoke shaft — male
1210008	3/8" x 1-3/16" (9.5 mm x 30.2 mm) bolt — 16 required per flange
1210009	3/8" (9.5 mm) nut — 16 required per flange



**OMSI-Hibon Driveline Assembly**

Part No.	Description
86592G	Upper driveline assembly
44665	Flanged yoke (Fig. 1)
43961	U-joint (Fig. 2)
48356	Yoke shaft for a 1610 (Fig. 3)
1211031	Bore flange
43962A	Slip yoke assembly for a 1610 (Fig. 4)

**TECH TIP:** Drivelines should be greased every 25 hours or weekly at a minimum. Poor maintenance and failure to grease drivelines will cause premature driveline failure and could cause blower failure.

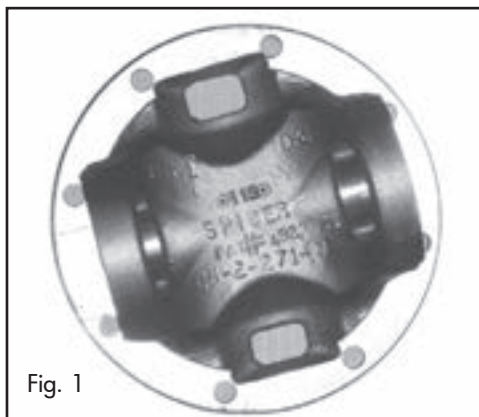

Fig. 1

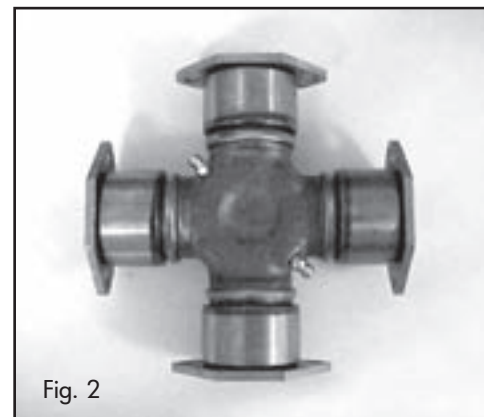

Fig. 2



Fig. 3



Fig. 4

## Cotta and OMSI Transfer Case

Part No.	Description
48017F	Flange yoke (Fig. 1)
48017B	U-joint (Fig. 2)

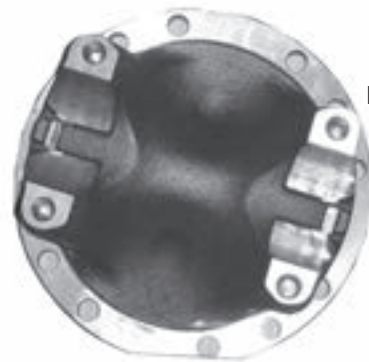

Fig. 1

## Upper Driveline

Part No.	Description
86592	Used on a 1021 DVJ
86592N	Used on NX ACE (Fig. 3)



Fig. 2

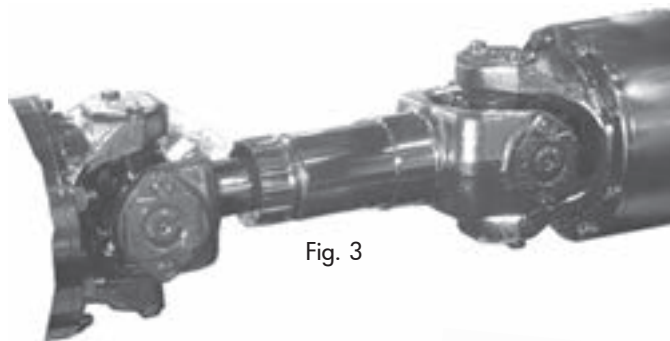

Fig. 3

## Driveshaft Assembly

Part No.	Description
48016T	For NX unit



## Bore Flange

Part No.	Description
1210014	6" (152 mm) used on select blowers — call with Guzzler serial number to confirm
1125257	5.5" (140 mm) keystack used on 6" (152 mm) bore flange 1210014
1210015	8" (203 mm) used on select blowers — call with Guzzler serial number to confirm
1125258	7.5" (191 mm) keyway used on 8" (230 mm) bore flange 1210015

