

Pipe Class 24 (SDR 7.4, S3.2)

MATERIAL

- **Body:** Cross Linked Polyethylene [Pe-Xa]

SPECIFICATIONS

- **Temperature rating:** -50°C/-58°F to 110°C/230°F

APPROVALS

ASTM F2905; UL Approved; AS/NZS 2492; NSF 61, DIN 16892/93, ASTM F2788; SABS 15875

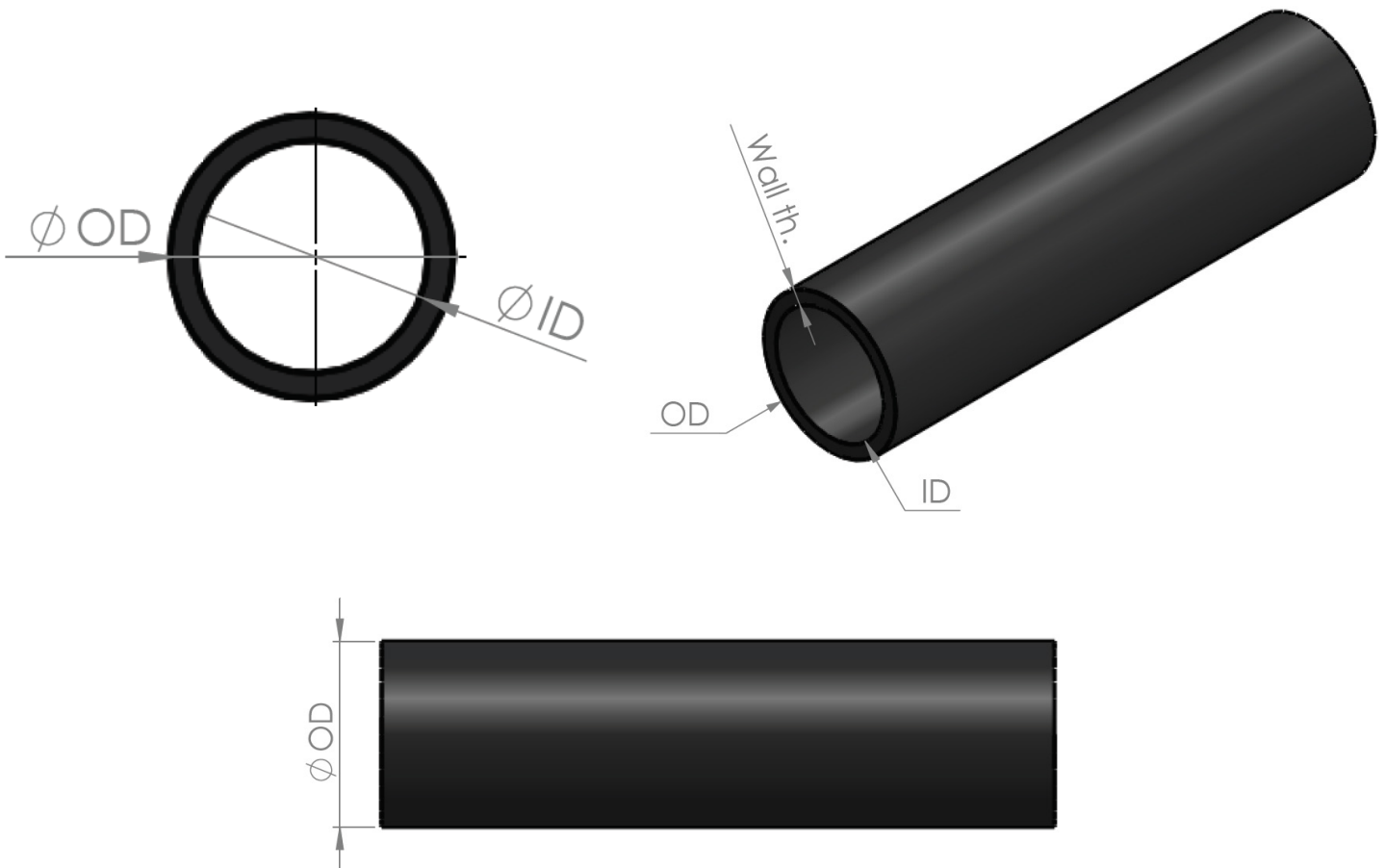

Pressure-Temperature De-rating Table

C/°F°	Bar/Psi
10°/50°	17.0/246.5
20°/68°	15.0/217.5
30°/86°	13.3/192.9
40°/104°	11.8/171.1
50°/122°	10.5/152.2
60°/140°	9.5/137.7
70°/158°	8.5/123.2
80°/176°	7.5/108.7
90°/194°	6.8/98.6
95°/203°	6.4/92.8
100°/212°	5.5/79.7
105°/221°	4.5/65.2
110°/230°	3.8/55.1

Cat No.	Pipe OD [mm]	Wall thickness [mm]	I.D. [mm]	Weight [Kg/m]
PA-122 N	12	2	8	0.06
PA-162.2 BLK	16	2.2	11.6	0.09
PA-202.8 BLK	20	2.8	14.4	0.15
PA-253.5 BLK	25	3.5	18	0.23
PA-324.4 BLK	32	4.4	23.2	0.38
PA-405.5 BLK	40	5.5	29	0.59
PA-506.9 BLK	50	6.9	38.2	0.92
PA-638.6 BLK	63	8.6	45.8	1.45
PA-7510.3 BLK	75	10.3	54.4	2.07
PA-9012.3 BLK	90	12.3	65.4	2.97
PA-11015.1 BLK	110	15.1	79.8	4.45
PA-12517.1 BLK	125	17.1	90.8	5.73
PA-14019.2 BLK	140	19.2	101.6	7.21
PA-16021.9 BLK	160	21.9	116.2	9.4
PA-18024.6 BLK	180	24.6	130.8	11.88
PA-20027.4 BLK	200	27.3	145.2	14.65
PA-22530.7 BLK	225	30.8	163.4	18.59
PA-25034.2BLK	250	34.2	181.6	23
PA-28038.3 BLK	280	38.3	203.4	29
PA-31543.1 BLK*	315	43.1	228.8	37
PA-35548.5 BLK	355	48.5	258	47
PA-40054.7 BLK*	400	54.7	290.6	59
PA-45061.5 BLK*	450	61.5	327	75
PA-50068.5 BLK*	500	68.5	363	93
PA-56076.7 BLK**	560	76.7	406.5	117
PA-63086.3 BLK*	630	86.3	457	148
PA-71097.3BLK**	710	97.3	515	185.4

1. QUALITY DEPARTMENT

- Golan's Quality department is ISO 9001:2015 certified.

1.1 Quality Control

It is under the quality control's responsibility to ensure that all products are manufactured according to the relevant standards. Our Quality control makes sure that every process, from raw materials to finished products, meets the requirements defined in the relevant standards and according to our quality plan.

All production processes are controlled by physical and chemical tests conducted by the laboratory and by on-line inspections.



- Pipe Production



- Hydrostatic Pressure Tests



- Dimensions (geometric) Tests

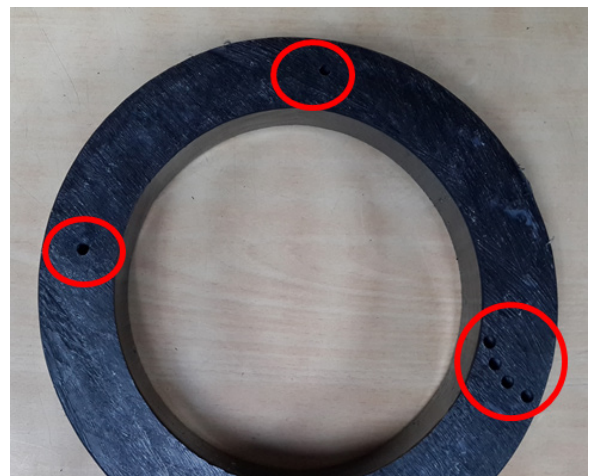

- Crosslinking Tests



- Crosslinking Tests

1.2 Traceability

Traceability procedures are included in Golan's quality control assurance procedures. The Traceability method is barcoded based and allows full traceability of the process starting from production through the Quality control tests and final approval. Further to the Barcode system, both a unique 6-digit number and manufacturing date are being stamped directly on the pipe to allow full traceability.

1.3 Raw material tests

Incoming batches of raw materials are placed under quarantine until all tests are done and results are reviewed and accepted.

The following tests are conducted on every batch of raw material:

Standard	Test
ASTM D1238 - ISO 1133	MFR
ASTM D6869 - ISO 15512	Water content
ASTM D1505 - ISO 1183	Density

1.4 Pexgol pipe properties

Test	Standard	Required	Nominal	Frequency
Resin				
MFR	ASTM D1238 ISO 1133	1.7 – 2.3	1.9	Every batch
Density	ASTM D1505 ISO 1183	926 kg/m ³	955 kg/m ³	Every batch
Water content	ASTM D6869 ISO 15512	<0.1%	<0.1%	Every batch
Master Batch				
Melt Flow Rate (MFR)	ASTM D1238	1.0 – 3.0	1.61	Every batch
Carbon Black Content CBC	ASTM D4218	2.0 – 2.6	2.4	Every batch
Pipe				
Density	DIN 53479	938 kg/m ³	938 kg/m ³	
Cross linking degree	ISO 10147	70%	80%	At least twice a batch
Elongation at break (at 20°C)	ISO 527	350%	> 400%	Every batch
Tensile strength (at 20°C) (at 100°C)	DIN 53455 -	19 N/mm ² 9 - 13 N/mm ²	> 19 N/mm ²	At least twice yearly
UV Resistance	ISO 14531-1, Annex C Resistance to weathering	a) Thermal stability b) 95°C hydrostatic strength c) Elongation at break	Comply	Type test
Longitudinal reversion	ISO 2505	< 3%	< 2.5%	Every Batch
Stabilizers migration	NCh2086	At least 50% of a virgin sample	> 50%	Annually
Oxidative Induction Time (OIT)	EN 728 ISO TR 10837	> 20 minutes at 200°C	> 40 minutes at 200°C	Every batch
Oven aging 160°	ATEC	After 100 hours, at least 50% elongation compared to virgin material	After 100 hours, 90% elongation compared to virgin material	Twice weekly
Thermal stability at 110°C	AS2492 DIN 16892	8760 h	> 10,000	Once per year
Pent test	ASTM F876	100 h	> 100 h	Once per year
Squeeze off	ISO 14531	1000 h (Pre cooling at -50°C)	> 1000 h	Type test
RCP	ISO 14531	lc/dn ≤ 4.7; at -50°C	lc/dn = 0.2 at - 50°C	Type test
Impact strength (at 20°C)	ISO 179	No failure	No failure	Type test
Impact strength (at -140°C) Surface energy Moisture absorption (at 20°C)		No failure 34 x 10 - 3 N/m 0.01 mg/4d	No failure 34 x 10 - 3 N/m < 0.01 mg/4d	Type test Type test
Oxygen permeability (at 80°C) for pipe with oxygen barrier O ²	DIN 4726	< 0.1 gr/m ² x day	0.02	Annually

Thermal properties

	Value	Unit	Tested for standard
Service temperature range	- 50 up to + 115	°C	
Coefficient of linear expansion (at 20°C)	1.4 x 10 ⁻⁴	m/m*°C	DIN53752
Coefficient of linear expansion (at 100°C)	2.05 x 10 ⁻⁴	m/m*°C	
Softening temperature	+ 133	°C	
Specific heat	2.3	kJ/kg*°C	DIN53765
Coefficient of thermal conductivity	0.35	watt/m*°C	DIN 4725

Electronic properties

	Value	Unit	Tested for standard
Specific internal resistance at 20°C	10 ¹⁶	Ω m	
Dielectric constant at 20°C	2.3	-	
Dielectric loss factor at 20°C/50Hz	1 x 10 ⁻²	-	DIN53483
Rupture voltage at 20°C	100	kV/mm	

1.5 Pexgol pipe tests

Pexgol pipes are manufactured in accordance with our standard procedures under an ISO 9001:2015 certified quality system.

Quality tests are conducted according to the requirements of API 15PX Paragraph 7 – “Quality Management Program” – as shown in the table below:

Table 8

Test Description	Result
Outside diameter	
Wall thickness	
Out of roundness	
Sustained pressure test - 165 hours	
Sustained pressure test – 1,000 hours	
Cross linking degree	

Further tests done in Golan

Test Description	Result
Thermal stability (OIT)	
Longitudinal reversion	
Oxidation	