



TREFOIL AND SINGLE CABLE CLEATS Type SmartCleat[®]



Being first is good, being smart is better, being both is Simply the Best!



PRODUCT PORTFOLIO

Oglaend System offer a broad range of cable support systems for all applications, e.g. cable ladders, cable trays, junction box racks, tubing clamps, cable cleats, heating cables, control systems etc.

**If you need further information,
please do not hesitate to contact us!**

Company presentation

Download our latest version of product catalogues from: www.oglaend-system.com



Subject to minor changes without notice.
Check our website for latest issues.

SmartCleat[®]

Think smart – work easy!

In consultation with several of our customers we have developed a complete trefoil and single cleat solution – the SmartCleat[®].

Despite its simple design and cost effective ease-of-installation, the SmartCleat[®] meets the major standards of strength, flexibility and protection.











The SmartCleat[®] has been thoroughly tested at Sintef Energy Research Centre in Trondheim, Norway and at IPH Berlin, Germany. See page 8-9.

In addition our SmartCleat[®] passed the requirements of the BAE Systems stringent testing and is installed on the Type 45 Destroyer Programme for the UK Ministry of Defence.

We are proud to present a SmartCleat[®] with all the characteristics you would expect from a professional cable cleating system.

The SmartCleat[®] design is patented.

SmartCleat[®] advantages for trefoil and single:

-  Saves space, both in height and width.
-  Plastic liners are not required for trefoil installations due to the design of the clamp providing a smooth surface.
-  Suitable for fixing to any preslotted rung design.
-  Fixing bolts are easily accessible from underneath the rung.
-  Low weight. Compact and light design.
-  The design fixes the cables so close to the rungs, that the rungs in between cleats give full support for distribution of load.
-  Low product price and low installation cost.
-  SmartCleat[®] trefoil cover cables from Ø 25 mm - Ø 99 mm and SmartCleat[®] single cables from Ø 39 mm - Ø 99 mm.
-  SmartCleat[®] is tested up to 160 kA-Peak (Sintef Trondheim, Norway).
-  SmartCleat[®] single and trefoil are certified by DNV according to IEC 61914.

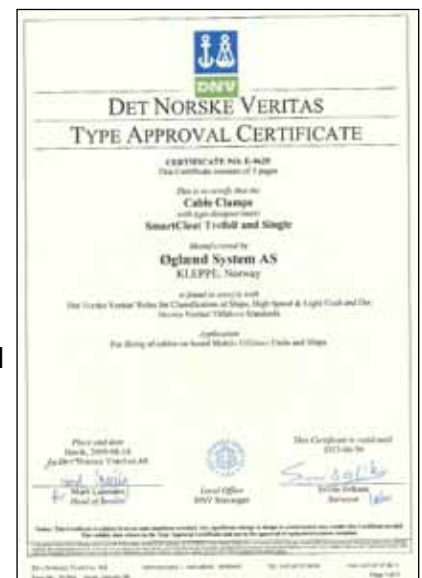



SmartCleat® trefoil:

SmartCleats Trefoil are normally manufactured in sizes to fit cable diameters from 3x25 mm to 3x99 mm.

For order codes see next page.

Fixing bolts and spacer are included in order code.

All trefoil cleats fits +/- 1.5 mm deviation.

Measurements calculation:

Width: 2 x cable diam + 12 mm.

Height: Approx 2 x cable diam + 18 mm.

Weights: From 0.35 kg for Ø 25 mm until 0.8 kg for Ø 99 mm.
The weight includes all boltset and fixing components.

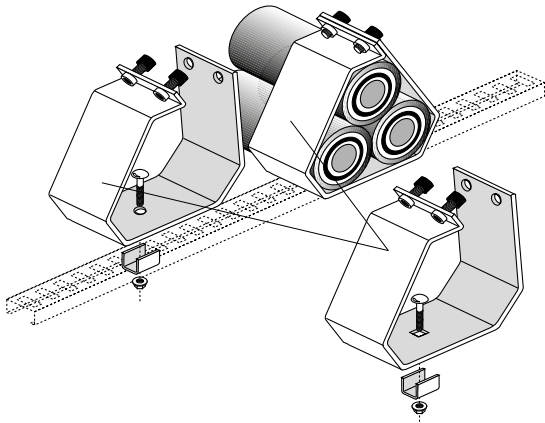
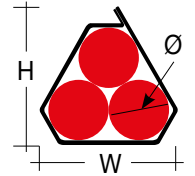

SmartCleat trefoil complete for 3x25 to 3x99 mm

Design Variations:

SmartCleat trefoil for Ø < 38mm and SmartCleat single Ø < 56mm have a different design than the larger cleats.

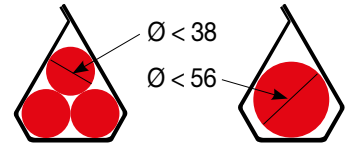

SmartCleat® single:

SmartCleats Single are normally manufactured in sizes to fit cable diameters from 1x37 mm to 1x99 mm.

Order codes see next page.

Fixing bolts/pads and spacer are all included in order code.
Pads are used up to 79 mm. See diagram and illustration.

All single cleats fit +/- 2 mm deviation.

Measurements calculation table:

Cable diameter:	Width:	Height:
Ø 37-40 mm	Cable dia. x 1.9	Cable dia. x 2.4
Ø 40-60 mm	Cable dia. x 1.6	Cable dia. x 2.0
Ø 60-88 mm	Cable dia. x 1.6	Cable dia. x 1.6
Ø 80-99 mm	Cable dia. x 1.6	Cable dia. x 1.6

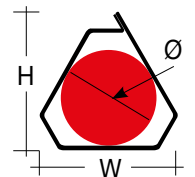

Weights: From 0.35 kg for Ø 37 mm to 0.8 kg for Ø 99 mm.
The weight includes all boltset and fixing components.

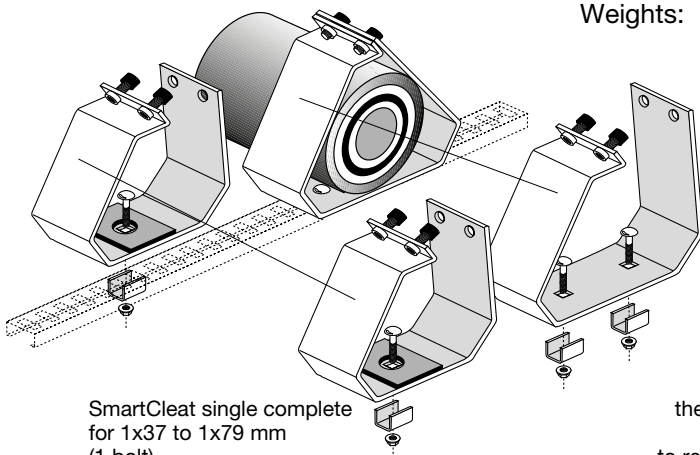

SmartCleat single complete for 1x37 to 1x79 mm (1 bolt)

SmartCleat single complete for 1x80 to 1x99 mm (2 bolts)

When cleat spacing is 600 mm the SmartCleats can be staggered along the length of the ladder as shown to reduce the required width of the ladder.

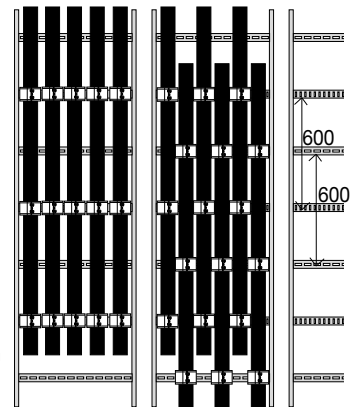

Ordering information SmartCleat® trefoil:

SmartCleat Trefoil, order codes: 13034XX - (XX = cable diameter),

e.g. art. no. 1303439 fits 3x39 mm and art. no. 1303447 fits 3x47 mm.

Fixing bolts and spacer are included in the article code.

All parts in Stainless Steel (AISI 316L).

Ordering information SmartCleat® single:

SmartCleat Single, order codes: 898XX - (XX = cable diameter),

e.g. art. no. 89839 fits 1x39 mm and art. no. 89879 fits 1x79 mm.

Fixing bolts/pads and spacer are all included in the article code.

A pad is used up to 79mm. See dia and ill. bottom page 4.

All parts in Stainless Steel (AISI 316L).

SmartCleat® is designed to fit all our ladder rung systems See below.

If used on RZE ladder system use the ordering code for SmartCleat and order in addition:

Washer Ø 6x25. Art. no.: 1371350 and Locking Bolt M6x20. Art. no.: 1371982

If used on the FRP ladder system U-Spacer must be ordered in addition. Art. no.: 1371887

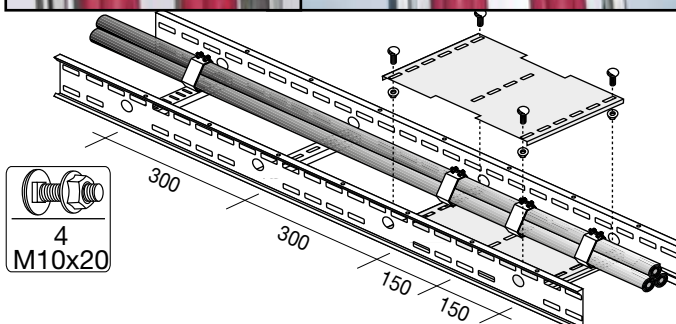
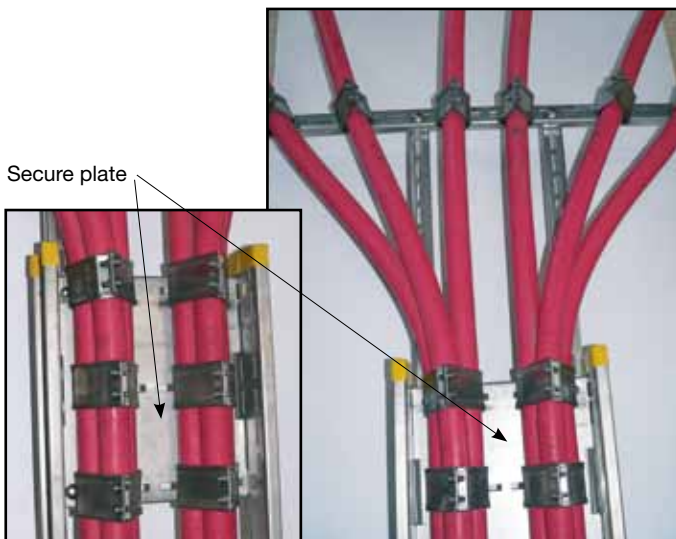
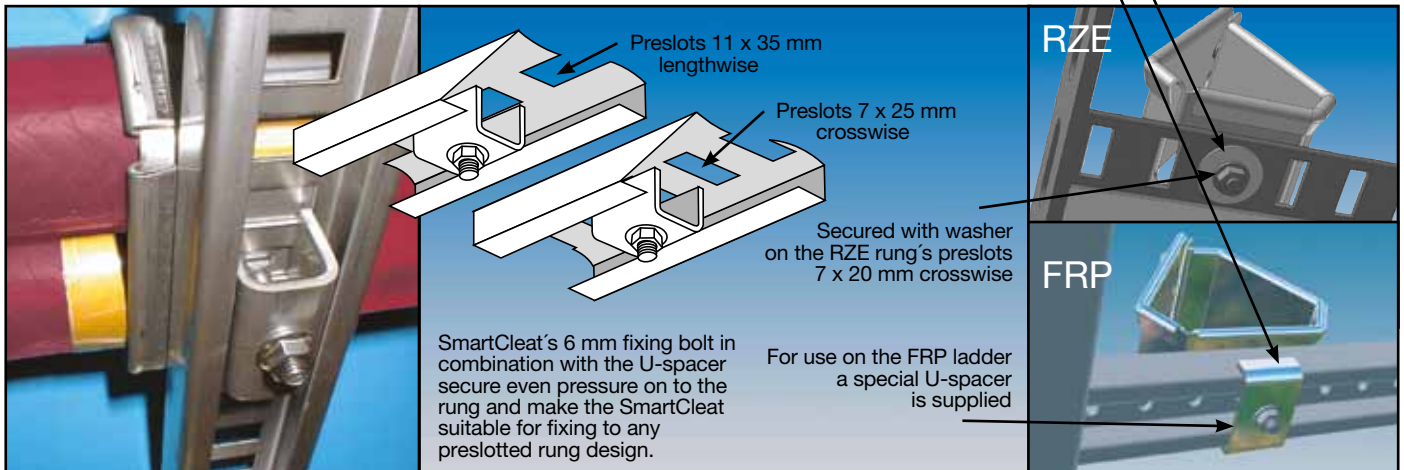

SmartSecuringPlate™:

Secure plates are **STRONGLY RECOMMENDED** to be used at both ends of a trefoil cable run.

Realistic tests (see page 9) done on several cable lengths and clamp distances confirms the theory that the cable must be additionally secured at both ends to reduce arching and eliminate deformation and stretch marks on the cable.

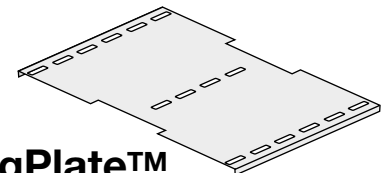

SmartSecuringPlate™

Type (state ladder width)	Art. no. SS
A-OE EX-Smarcl-150	87544
A-OE EX-Smarcl-300	87545
A-OE EX-Smarcl-450	87546
A-OE EX-Smarcl-600	87547
A-OE EX-Smarcl-750	87548
A-OE EX-Smarcl-900	87549

The SmartSecuringPlate™ is designed to fit all standard ladder types with 300 cc rungs.

This includes our RZE and FRP systems.

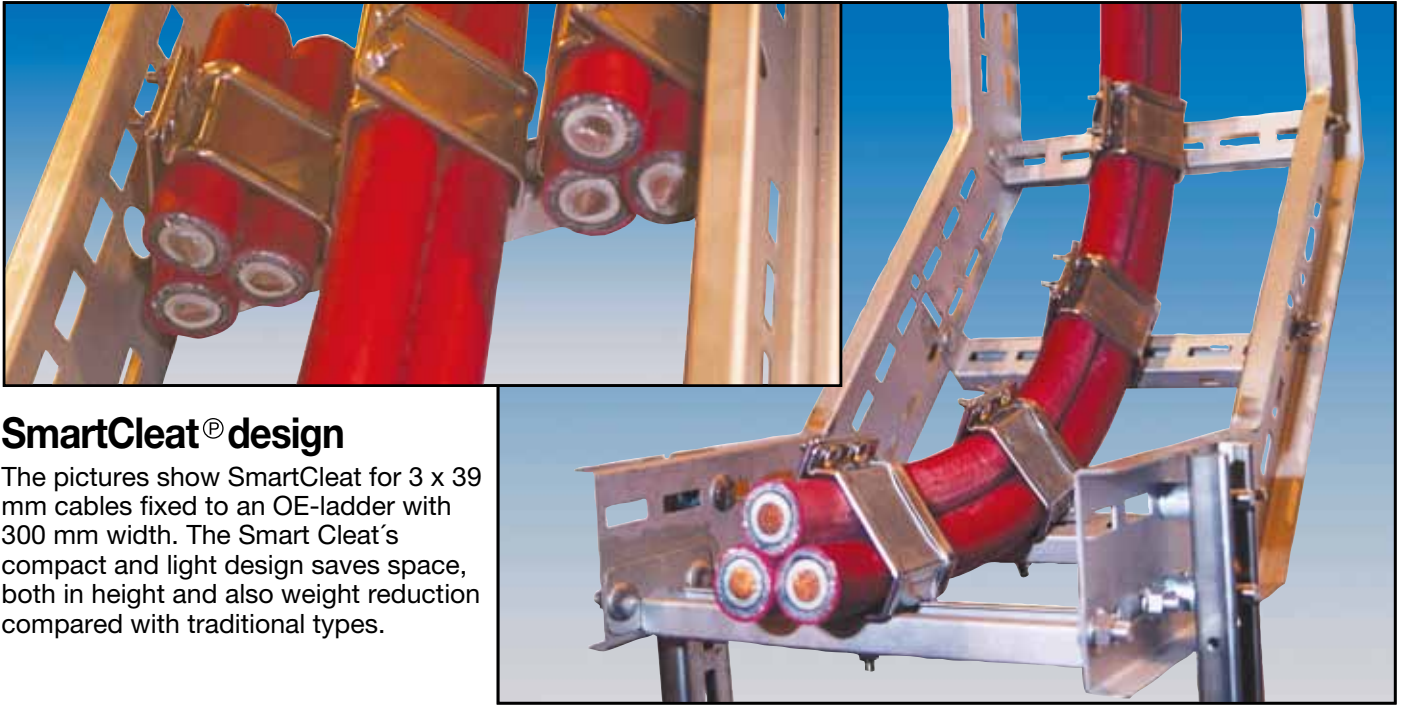

SmartCleit® design

The pictures show SmartCleit for 3 x 39 mm cables fixed to an OE-ladder with 300 mm width. The Smart Cleit's compact and light design saves space, both in height and also weight reduction compared with traditional types.

SmartCleit® trefoil (and single) installation step by step:

Spacer bracket in rung is fastened with M6x40 mm lock bolt.

Install the cables.

When the last cable is in place bend this side towards the nut side.



Allen key is placed in centre hole to align the holes for easier installation of the bolts. We recommend to tighten with Allen Key.

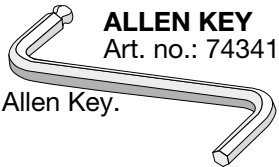

NB! Use slow speed if tighten with power drill.

Complete installation guide is available on request.



Snøhvit, Statoil



Snøhvit, Statoil



Bayu-Undan,
Conoco Phillips
Australia



2-4M,
Conoco
Phillips



Ormen Lange, Hydro

SmartCleat® Summary from the Sintef, Trondheim, Norway test (2002): A mechanical cable cleat test

TREFOIL CABLE CLEAT

Trefoil Cable Cleats are mainly used for holding high voltage single core cables in triangular form, but can also be used for single cables and bundles of cables.

SmartCleat fits cables between 25-99 mm in diameter and

single cables or bundles of cables up to 99 mm in diameter. SmartCleat is specially made to resist the extreme dynamic energy which can occur with powerful short circuits in electrical installations.

The cleats are tested with short circuits up to 160 kA-Peak.

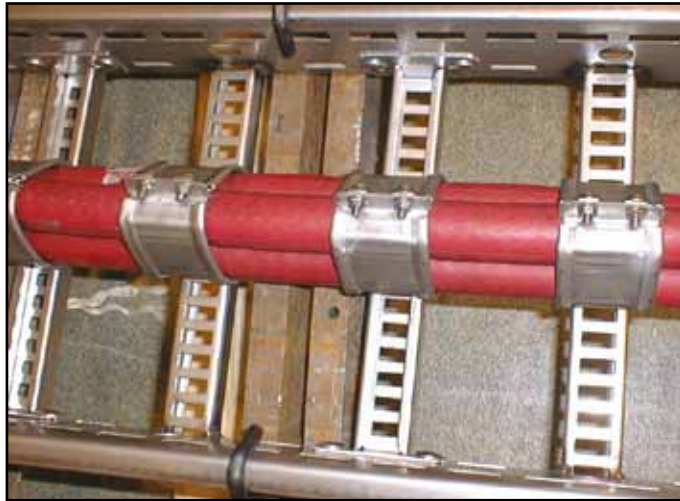

SmartCleat® trefoil cable cleats

have been tested to meet the highest customer standards for short circuit current. Here are some of the test results from Norwegian testing institute Sintef:

Cleat spacing: 150 mm

Short circuit current: 160 kA peak.

Result. RMS 87 kA

Cleat becomes slightly "rounder" in shape, but without reducing strength and functionality.

Cable shows no arching or damage.

Cable ladder shows no deformation.



Cleat spacing: 300 mm

Short circuit current: 135 kA peak.

Result. RMS 73 kA

Cleat becomes slightly "rounder" in shape, but without reducing strength and functionality.

Cable shows clear arching and stretch marks may appear on mantle.

Cable ladder shows no deformation.



Cleat spacing: 600 mm

Short circuit current: 133kA peak.

Result. RMS 72 kA

Cleat becomes slightly "rounder" in shape, but without reducing strength and functionality.

Cable shows clear arching and stretch marks may appear on mantle.

Cable ladder shows slight deformation on intermediate rungs.



Cleat spacing: 900 mm

Short circuit current: 103kA peak.

Result. RMS 65 kA

Cleat shows no visible change.

Cable shows clear arching and stretch marks and some damage.

Cable ladder shows insignificant deformation on side pieces and intermediate rungs.

As the photos show, the neatest and most functional solution is to cleat the cable with close spacings - which also ensures that the cable is fully reusable.

Wider spacings do not usually result in greater loads on cleats, but the broad arch of the cable can damage the surroundings and stretch the terminations. A non-heavy duty mantle may get damaged from impact with the intermediate rung. Choice of cleat spacing should therefore be decided in consultation with the cable supplier.

SmartCleat® Summary from the IPH, Berlin, Germany test (2006): Tested cable functionality and recommended cleat spacing

What to expect from the tests:

Would realistic tests done on several cable lengths and clamp distances confirm the theory that the cable must be additionally secured at both ends to reduce arching and eliminate deformation and stretch marks on the cable?

Result of the test.

By using a secure plate (rung reinforcing plate) at both ends of the cable run it confirms:

- Less arching on the cable.
- Less stretch at terminated ends – significant point in regard to functionality following short circuiting.
- No stretch marks on outer cable sheath.
- No stretch/deformation of rungs at the end of the cable ladder.

In addition, the tests obtained important data for making the following recommendation concerning maximum cleat spacing, see table 2.

The tests were carried out without any damage to the cable, even when using clamps two sizes too large with or without extra rubber inserts.

The test procedure was set up following dialogue with Draka Norsk Kabel and a Statoil representative.

In order to set realistic maximum test values for the most common cable cross-sections 150/240/300 mm², we chose to use a formula from NEK 606 which gives values as recommended in EN 50368. The formula states what is maximum short-circuit current for a cable without the centre core becoming so hot that it weakens the insulation sheath (250 °C).

Short-circuit level given by the formula (Example 300 mm²):

$$\frac{140A \times 300 \text{ mm}^2}{\sqrt{0.1 \text{ sec.}}} = 132kA \sim 135kA$$

(square root of the short-circuit time)

150 mm² = 70kA
240 mm² = 105kA
300 mm² = 135kA

These are the values for the basis of the SmartCleat tests. We make the following cleat spacing recommendations, see table 1. (These are maximum load recommendation.) For more detailed values, please see table 2. Please note that the cable tested was a Draka cable RFOU.

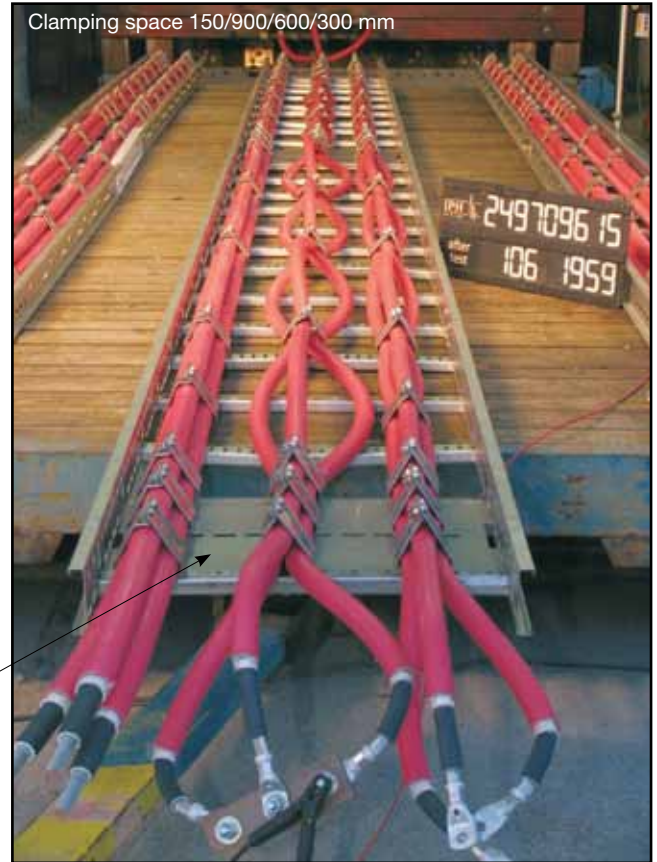

According to the test we **strongly recommend** SmartSecuring Plate™ to be used at both ends of a trefoil cable run. See page 5.

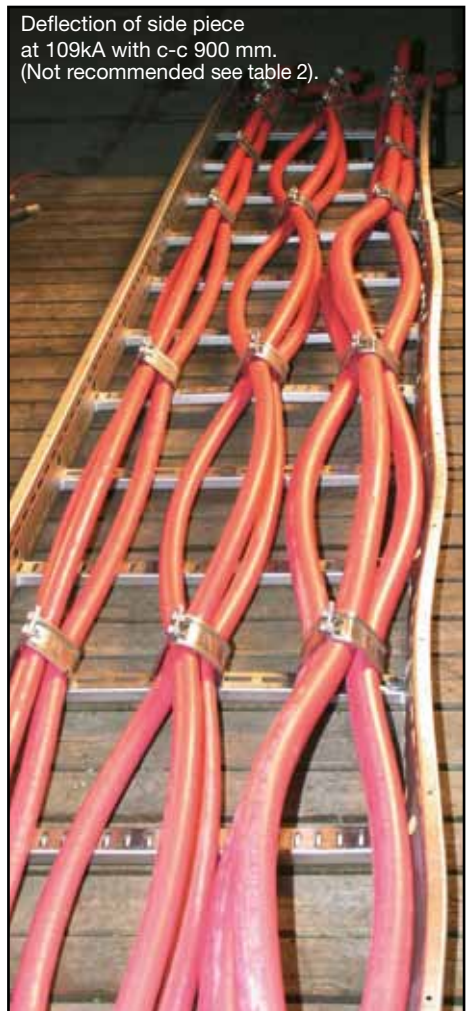

Deflection of side piece at 109kA with c-c 900 mm. (Not recommended see table 2).

Table 1 Recommended cleat spacing

Cross-section	Short circuit current	Cleat spacing	Comments
150 mm ²	70kA	900 mm	77 mm arching – No damage on ladder.
240 mm ²	105kA	600 mm	35 mm arching – Some damage on side piece.
300 mm ²	135kA	300 mm	7 mm arching – Diminutive damage of side piece.

Table 2 Recommended cleat spacing

Cross-section	Short circuit current	Cleat spacing	Comments
150 mm ²	70kA	900 mm	77 mm arching – No damage on ladder.
150 mm ²	87kA	600 mm (900)*	72 mm arching (120mm)* – No damage of ladder (Rung deform.)
240 mm ²	109kA	600 mm (900)*	35 mm arching (125mm)* – Some damage of side piece due to big cable arching.
240 mm ²	118kA	600 mm	35 mm arching
300 mm ²	135kA	300 mm (600)*	7 mm arching (74 mm)* – Diminutive damage of side piece and rung due to cable arching.
300 mm ²	154kA	300 mm	7 mm arching – Diminutive damage.

* Figures in brackets show tested spacing/arching without damage of cleat or cable but not to be recommended based on too much arching on the cable.

SmartCleat® Summary from the Oglænd System R&D dpt., Klepp, Norway (2009): Mechanical Properties tested according to IEC 61914



Lateral Load Test

Ref: IEC 61914. Section 9.3.

What to expect from the test:

The cable cleat shall be capable of supporting the lateral load.

Result of the test:

Maximum lateral load is 700 kg.



Axial Movement Test

Ref: IEC 61914. Section 9.4.

What to expect from the test:

The cable cleat shall be resistant to axial movement.

Result of the test:

Maximum axial movement load is 30 kg.

It is recommended to use a pad (Art. no. 84038) in case of long vertical cable runs.



Impact Test

Ref: IEC 61914. Section 9.2.

What to expect from the test:

The cable cleat shall be resistant to impact at ambient temperature.

Result of the test:

Impact energy tested: 20 J.

Impact test classification: Very heavy.

LOCATIONS

HOLDING COMPANY

Øglaend Industrier AS
P.O. Box 133
NO-4358 Kleppe
Tel.: + 47 51 78 81 00
Fax: + 47 51 78 81 60
www.oglaend-system.com

SUBSIDIARY

Norway

Øglaend System AS
P.O. Box 133
NO-4358 Kleppe
Tel.: + 47 51 78 81 00
Fax: + 47 51 78 81 60
Fax sales office: + 47 51 78 81 61
Email: oglaend@oglsys.no
www.oglaend-system.com

Denmark

Øglaend System AS
Tel.: +45 86 88 66 66
Fax: +45 86 88 66 67
Email: oglaend-system@oglsys.dk

Dubai (Middle East)

Øglaend Industries Middle East
Tel.: + 971 4 887 8134
Fax: + 971 4 887 8143
Mobile: + 971 50 55 86 183
Email: sales@oglaend.ae

Malaysia

Øglaend Industries SDN BHD
Tel.: + 60 3 51 922 049
Fax: + 60 3 51 922 039
Mobile: + 60 1 26 85 57 65
Email: sales@oglaendind.com
fraser@oglaendind.com

The Netherlands

Øglaend System BV
Tel.: + 31 1804 14 204
Fax: + 31 1804 19 395
Email: rfrq@oglaend-system.nl

Russia (St. Petersburg)

Øglaend System Russia
Tel.: +7(812) 313 1580
Fax: +7(812) 313 1580
Email: info@oglsys.ru
www.oglaend-system.ru

Singapore (South East Asia)

Øglaend System Singapore Pte. Ltd.
Tel.: + 65 67 48 82 78
Fax: + 65 67 48 86 15
Email: oglaend.system@pacific.net.sg

Sweden

Øglaend System AB
Tel.: + 46 40 45 74 60
Fax: + 46 40 45 67 25
Email: oglaend-system@oglsys.se

UK

Øglaend System UK Ltd.
Tel.: + 44 121 552 9662
Fax: + 44 121 544 6627
Email: oglaend.system@oglsys.co.uk

USA

Øglaend System USA
Tel.: +1 832 288 4452
Email: sales@oglsys-us.com

Korea

Øglaend System Korea Co Ltd
Tel.: + 82 518 320 761
Fax: + 82 518 320 762
Email: oglaend@oglaend-system.co.kr

SALES OFFICES

Norway

Øglaend System AS, Division Oslo:
Tel.: + 47 22 25 15 10
Fax: + 47 22 25 25 21

Øglaend System AS, Division Ålesund:

Tel.: + 47 70 19 09 50
Fax: + 47 70 19 09 51

Øglaend System AS, Division Trondheim:

Tel.: + 47 73 80 99 70
Fax: + 47 73 80 99 77

AGENTS - DISTRIBUTORS

Abu Dhabi

Proserv Albadi LLC
Tel.: + 971 26 27 73 70
Fax: + 971 29 27 79 72
Email: proserv@emirates.net.ae
www.proserv.no

Australia

J. T. Day Pty. Ltd.
Tel.: + 61 8 9303 2248
Fax: + 61 8 9303 2446
Email: enquiries@jtday.com.au
www.jtday.com.au

Brazil

M.O.TECH do Brazil
Tel.: + 55 21 2532 2101
Fax: + 55 21 2517 2437
Email: motech@motech.com.br
www.motech.com.br

Brunei

Shinba Integrated Engineering Services
Tel.: + 673 333-1489
Fax: + 675 333-6333
Email: info@shinbaies.com

Canada

Apel/CSA Enterprises
Tel.: + 1 902 450 5647
Fax: + 1 902 450 5286
Email: urquhart@csarep.com
www.csarep.com

NOSO Ltd.

Tel.: + 1 709 782 2645
Fax: + 1 709 782 0534
Email: mshinkle@coil.ca
www.noso.ca

Finland

Elmarino - Shipping OY
Tel.: + 358 22 54 61 00
Fax: + 358 22 54 62 76

Finn H&T Group Oy

Tel.: +358 45 630 4004
Fax: +358 3 5752550
Email: teppo.kuivanen@finnhtgroup.fi
www.finnhtgroup.fi

Iceland

Smith & Norland
Tel.: + 354 52 03 000
Fax: + 354 52 03 011
Email: sminor@sminor.is
www.sminor.is

Indonesia

PT. Multi Tarex Mulia
Tel.: + 62 21 3983 5337
Fax: + 62 21 3983 5340
Email: agus@multitarex.co.id
www.multitarex.com

Italy

Piemme Broker S.R.L.
Tel.: +39 02 906 33621
Fax: +39 02 906 32036
Email: m.maiani@pmbroker.it
www.pmbroker.it

Malaysia

Offshore Industries Sdn Bhd
Tel.: + 60 3-9284 0613
Fax: + 60 3-9284 1051
Email: oisbkl@tm.net.my

Poland

Nd Service Sp. Z.O.O.
Tel.: + 48 665 070 111
Email: wojciech.pedzich@ndservice.pl
www.ndservice.pl

Thailand

Probit International Co Ltd.
Tel.: + 66 2 710 6146 Ext. 107
Fax: + 66 2 710 6147
Email: ak@probity.co.th
www.probity.co.th

The Baltic States

Bastini OÜ
Tel.: + 372 660 5811
Fax: + 372 660 5812
Email: sales@bastini.ee

Vietnam

MT Corp.
Tel.: + 848 821 0373
Fax: + 848 821 0358
Email: mail@mt-co.com



- * HEAD OFFICE AND FACTORY
- SUBSIDIARIES
- AGENTS - DISTRIBUTORS
- ▲ SALES OFFICES
- × FABRICATION FACILITIES

SIMPLY THE BEST!

This has been our motto since the company was founded in 1977. By living up to the motto we have become the market leader in our field – worldwide.

Oglaend System's goal is to develop systems that are better, simpler and more economic overall.



Konsern/Holding company:
Øglænd Industrier AS

Datterselskap/Subsidiary:
Øglænd System AS
Hovedkontor fabrikk/Head Office factory:
P.O. box 133, NO-4358 Kleppe,
Tel.: +47 51 78 81 00, Fax: (47) 51 78 81 60
Fax sales office: +47 51 78 81 61