

**Temperature Rated Ultra
NBR 162
13-5/8" 5K SBOP
Annular Packing Unit
API-16A Design Validation
Customer Data Package**

For more information regarding our
Temperature Rated Ultra
Annular Packing Units
please contact:

Freudenberg Oil & Gas Technologies

9902 Fallbrook Pines Drive, Suite 100
Houston, Texas 77064 USA

Phone: +1 281-591-1500
(M-F 8 AM – 5 PM Central Time US)

After Hours, call: +1 713-397-0009

Fax: + 1 281-591-1510

www.fogt.com

Table of Contents

Table of Contents.....	3
Summary	4
Testing Requirements.....	5
Material Data Sheet	6
Temperature Ratings	7
Product Description.....	8
Dimensional Details	8
Elastomer Storage Guideline for FO> Pressure Control Products.....	9
Test Certificates	11
API Q1 Certification	15
API 16A Certification.....	16
Certificate of Quality.....	17
Product Certificate	18

Temperature Rated Ultra NBR 162 13-5/8” 5K SBOP Annular Packing Units API-16A Design Validation

Summary

Freudenberg Oil & Gas Technologies (FO>) Temperature Rated Ultra NBR 162 13-5/8” 5K SBOP Annular Packing Units have completed design validation testing per the following sections of “Specification for Drill-through Equipment”, API 16A 4th Ed.:

- 4.7.3.21 PR1 Fatigue Test, Annular BOP
- 4.7.3.27 PR2 Low Temperature Design Validation, Annular Type BOP
- 4.7.3.29 PR1 and PR2 Extreme High Temperature Design Validation, Annular Type BOP

Design validation testing was performed with OEM or CEM pressure control equipment specified in accordance to the relevant API specification and OEM requirements.

Copies of the test certificates are included at the end of this document; the original certificates are located at our Petroleum Elastomers (PE) facility in Houston, TX as a part of their quality program.

Temperature Rated Ultra NBR 162 13-5/8” 5K SBOP Annular Packing Units are manufactured in FO>’s API Q1 and API-16A certified facility in Houston, Texas. Every unit is factory acceptance tested (FAT) before shipment. An FO> certificate will be sent with each Temperature Rated Ultra Annular Packing Unit, certifying that it meets FO> quality standards, has been manufactured in compliance with API-16A requirements and has been tested per API-16A FAT requirements.

Testing Requirements

All tests except for temperature testing were conducted using water at an ambient temperature as the wellbore fluid. The system hydraulic pressure was 1,500 psi as recommended by the BOP manufacturer. Table 1 shows all the tests that are required to be in compliance with API-16A design validation.^a

Tests Completed for FO> Temperature Rated Ultra, NBR 162, 13-5/8” 5K SBOP Annular Packing Unit

Test	PR1 Section	PR2 Section	PR2 Minimum Performance Criteria
Fatigue	4.7.3.21		26 pressure cycles
Low Temperature		4.7.3.27	3 pressure cycles
Extreme High Temperature	4.7.3.29	4.7.3.29	1 hour hold time

Table 1

^a Table 1 is excerpted from API 16A 4th Ed. Table 27 and modified to reflect the testing completed to validate the annular packing unit to meet performance requirement level PR1.

PR1 Fatigue Test

This test determines the ability of an annular packing unit to maintain a low-pressure seal (200 psi to 300 psi), and a rated working pressure (5,000 psi) seal throughout repeated closings and openings. This test simulates closing and opening the blowout preventer once per day and wellbore pressure testing at full rated working pressure once per week comparable to one year of service.

PR2 Low Temperature Test

This test determines the ability of the annular packing unit used as a pressure-controlling part to maintain a wellbore pressure seal after repeated closings and openings at the minimum rated temperature and rated working pressure of the annular packing unit.

PR1/PR2 Extreme High-Temperature Test

This test determines the ability of the annular packing unit used as a pressure-controlling part to maintain a wellbore pressure seal at the extreme rated temperature and rated working pressure of the annular packing unit.

Acceptance Criteria

The acceptance criterion for all tests that verify pressure integrity is zero visible leakage, as established by FO> standards.

Material Data Sheet

NBR 162

Physical properties

Typical Values

Hardness

ASTM D 2240, Shore A, Max Readout

79.0 Shore

Tensile strength

ISO 37 / ASTM D 412, S2

3700 Psi

25.5 MPa

Modulus

ISO 37 / ASTM D 412, S2

50% Modulus
100% Modulus

370 Psi
620 Psi

2.6 MPa
4.3 MPa

Elongation at break

ISO 37 / ASTM D 412, S2

520.0%

Tear strength

ISO 34-1 figure 2 / ASTM D 624-C

329 pound/inch

Compression set

ISO 815-B / ASTM D 395 -1

72h at 80 °C (176°F)
24h at 80 °C (176°F)

29%
18%

Change after aging in IRM 903: 70h at 100°C (212°F), ASTM D 471

ASTM D 2240, Shore A, Max Readout
Tensile strength (ISO 37 / ASTM D 412, S2)
Elongation at break (ISO 37 / ASTM D 412, S2)
Volume change (ISO 1817)

-4
-31%
-52%
11%

Change after aging in IRM 901: 70h at 149°C (300°F), ASTM D 471

ASTM D 2240, Shore A, Max Readout
Tensile strength (ISO 37 / ASTM D 412, S2)
Elongation at break (ISO 37 / ASTM D 412, S2)
Volume change (ISO 1817)

8
-1.1%
-48.9%
-7.0%

Listed values are nominal values based on testing performed by FO> in accordance with industry testing standards. Actual values may vary.

Temperature Ratings

The Freudenberg FO> Temperature Rated Ultra, NBR 162, 13-5/8" 5K SBOP Annular Packing Unit has been temperature tested per API 16A and meets the requirements for temperature classification per Table 4 in API 16A 4th Ed. at a performance requirement level 1 (PR1).

Table 4 - Temperature Ratings for Non-Metallic Sealing Materials								
Low Temperature Limit (first digit)			Continuous Elevated Temperature Limit ^a (second digit)			Extreme Temperature Limit (third digit)		
Code	Temperature		Code	Temperature		Code	Temperature	
	°C	°F		°C	°F		°C	°F
A	-26	-15	A	66	150	A	82	180
B	-18	0	B	82	180	B	93	200
C	-12	10	C	99	210	C	104	220
D	-7	20	D	116	240	D	121	250
E	-1	30	E	132	270	E	149	300
F	4	40	F	149	300	F	177	350
G	Other	Other	G	Other	Other	G	Other	Other

^anot required for PR1
EXAMPLE Material "FDE" has a low temperature rating of 40 °F, a continuous elevated temperature rating of 240 °F, and an extreme temperature limit of 300 °F.

Per API 16A marking requirements, a middle code letter "G" is used for products temperature tested to PR1.

Product Description

FOGT Part #	Element Type	Element Description			Element Style	API Temp. Rating	Temperature Range
		Element Size	Rated Working Pressure	Type			
10108521-33	Temperature Rated Ultra NBR 162	13 5/8"	5,000 psi	Spherical	Shaffer Style	FGF	40F to 350F (4C to 177C)

Dimensional Details

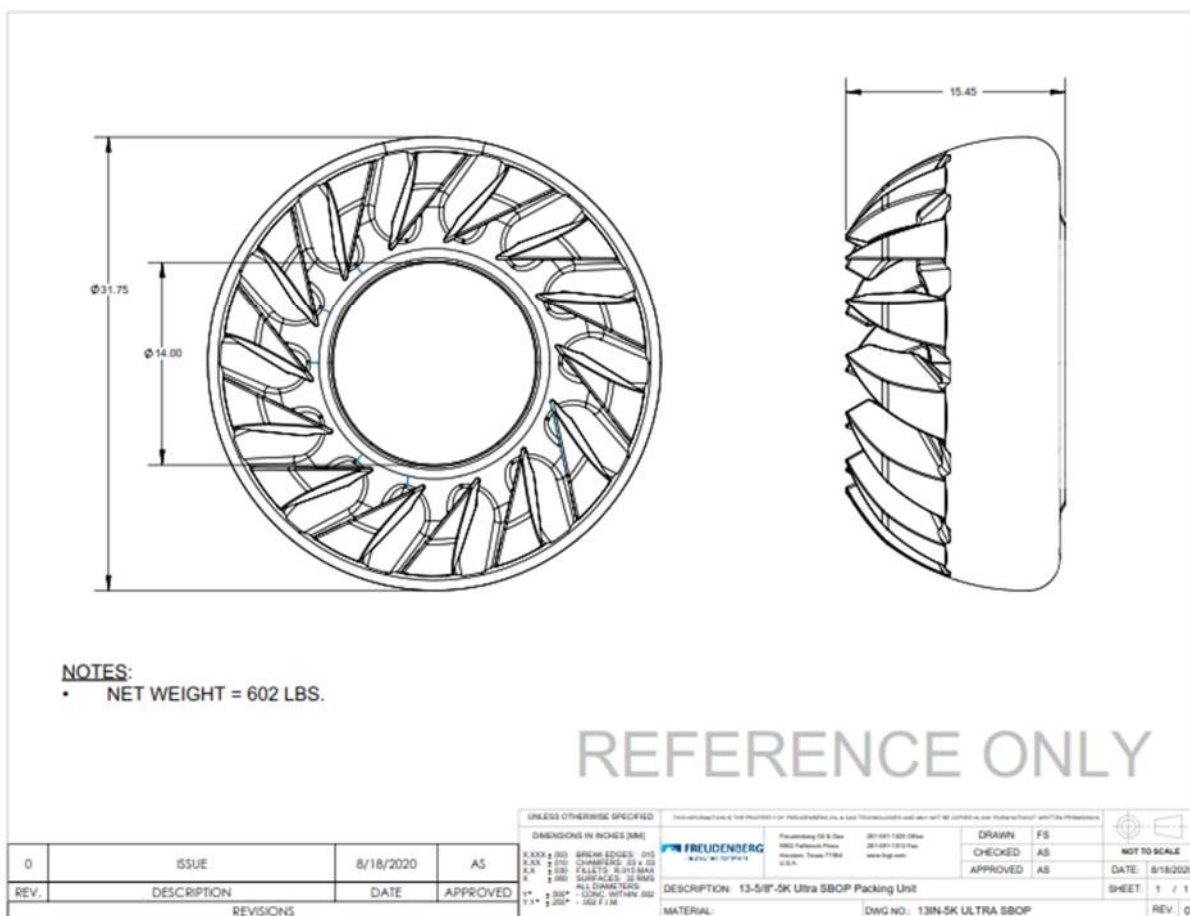

Elastomer Storage Guideline for FO> Pressure Control Products

The following guideline describes how ram blow-out preventer (BOP) packers, annular BOP packing units, and all other related BOP elastomeric seals should be properly stored to achieve the stated shelf life for each elastomer type as noted in Table 2.

Most polymeric items, including vulcanized rubber and other elastomers, tend to change their properties during storage. Without the proper handling, parts could become defective due to hardening, softening, cracking, crating or other degradation as the result of oxygen, ozone, light, heat and/or humidity.

The aging process is predominantly dependent on the following factors:

- Temperature
- Humidity
- Light
- Oxygen and Ozone
- Deformation

As such, the following storage recommendations are suggested to better preserve both elastomer properties and composite items:

Temperature

Storage temperatures should not exceed 75°F. Low temperatures are not directly correlated to permanent damage if elastomeric items are carefully handled and not distorted. When items are taken out of low temperature storage of 60°F or less, then they should be warmed up to approximately 85°F prior to installation.

Humidity

Optimum humidity should be approximately 65% in a draft-free atmosphere.

Light

It is highly important to protect elastomeric items from direct sunlight and/or strong artificial light with a high ultraviolet content. Unless items are packed in opaque containers, it is advisable to cover storage windows with red or orange screens or coatings.

Oxygen and Ozone

Elastomeric items should be protected from circulating air while in storage by remaining wrapped or bagged. Items should be stored in rooms apart from equipment that creates electric sparks or discharges as the ozone released is particularly harmful to rubber.

Deformation

Where possible, rubber items should be stored in a relaxed position, free from tension or compression. Laying the item flat, avoiding suspension or crushing, will keep it free from strain and will minimize deformation.

Stock Rotation

Elastomers should be stored for as short a period as possible, and strict stock rotation should be followed.

Cleaning

Organic solvents such as trichloroethylene, carbon tetrachloride and petroleum are the most harmful agents and should be avoided. Soap and water and methylated spirits are the least harmful. All parts should be dried at room temperature before use.

Shelf Life

The table below shows the storage life of seal components made from common elastomer materials stored under the conditions covered by these guidelines. Improper storage will reduce the shelf life.

If the shelf life or expiration dates marked on the part or packaging is different than the period listed in Table 2, the part or packaging dates shall be followed.

Elastomer	Maximum Storage Period (years)
Nitrile (NBR)	7

Table 2

Test Certificates

The following tests were performed in accordance with API-16A as part of the FO> design validation process. All tests met or exceeded API-16A standards. The list of the tests performed, and their corresponding certificates, are as follows:

Temperature Rated Ultra NBR 162 13-5/8" 5K Annular Packing Units – API-16A 4th Edition

Test	Certificate ID
Fatigue Test	C-00064
High Temperature Test	C-00062
Low Temperature Test	C-00063

Fatigue Test

 **FREUDENBERG**
INNOVATING TOGETHER

OIL & GAS TECHNOLOGIES

Certificate of Test

Freudenberg Oil & Gas Technologies' 13 5/8" x 5,000 psi NBR 162 Ultra annular packing unit was successfully tested with 364 close and open cycles and 52 low/high pressure tests for fatigue design validation in accordance with API 16A, Fourth Edition, section 4.7.3.21 PR1 procedures and acceptance criterion.

Product Details: FOGT 13 5/8" x 5,000 psi Ultra Annular Packing Unit NBR 162

Manufacturer: Freudenberg Oil & Gas Technologies
Part Number: 10108521-33
Batch Number: 7896-7900
Compound Description: NBR 162 Elastomer

Test Parameters

Validation Test Standard: API 16A Fourth Edition PR1, Fatigue Test
BOP Type: Annular, 13 5/8" x 5,000 psi
BOP Model: BOP Products Series 800 13-5/8" 5K
BOP Serial Number: B263-19/BR-008
Wellbore Low Pressure, minimum: 16 bar 227 psi
Wellbore High Pressure, minimum: 348 bar 5044 psi
Closing Pressure, maximum: 109 bar 1580 psi
Test Medium: Water
Hold Duration: 3 minutes
FOGT Work Order: 2020 142

Test Details

Test Performed by: Freudenberg Oil & Gas Technologies
Test Location: Materials Development & Product Testing Lab
4535 Brittmoore Rd. Houston, TX 77041
Internal Test Procedures: SOP-00125/1, in accordance with API 16A Fourth Edition, PR1
Test Completion Date: August 16, 2020
Test Results: No visible leakage during the hold periods

Authorized by:
Michael LoGiudice

Manager, HOU LAB Facility

C-00064/1

Copyright © 2020 Freudenberg Oil & Gas Technologies. All rights reserved

High Temperature Test

		OIL & GAS TECHNOLOGIES	
<p>Certificate of Test</p> <p>Freudenberg Oil & Gas Technologies' 13 5/8" x 5,000 psi NBR 162 Ultra annular packing unit was successfully tested for Extreme High Temperature design validation at 350°F in accordance with API 16A, Fourth Edition, section 4.7.3.29 PR2 procedures and acceptance criterion.</p>			
<p>Product Details: FOGT 13 5/8" x 5,000 psi Ultra Annular Packing Unit NBR 162</p>			
Manufacturer:	Freudenberg Oil & Gas Technologies		
Part Number:	10108521-33		
Batch Number:	2013-2020		
Compound Description:	NBR 162 Elastomer		
<p>Test Parameters</p>			
Validation Test Standard:	API 16A Fourth Edition PR2, Extreme High Temperature Test		
BOP Type:	Annular, 13 5/8" x 5,000 psi		
BOP Model:	BOP Products Series 800 13-5/8" 5K		
BOP Serial Number:	B263-19/BR-008		
Wellbore Temperature, minimum:	177 °C	350 °F	
Temperature Class:	F	350 °F	
Wellbore Pressure, minimum:	358 bar	5186 psi	
Closing Pressure, maximum:	103 bar	1494 psi	
Test Medium:	Cosmolubric B230		
Hold Duration:	60 minutes		
FOGT Work Order:	2020 050		
<p>Test Details</p>			
Test Performed by	Freudenberg Oil & Gas Technologies		
Test Location	Materials Development & Product Testing Lab 4535 Brittmoore Rd. Houston, TX 77041		
Internal Test Procedures	SOP-00130/1, in accordance with API 16A Fourth Edition, PR2		
Test Completion Date	May 19, 2020		
Test Results	No leakage during the hold period		
<p>Authorized by:</p>			
Michael LoGiudice			
			
Manager, HOU LAB Facility			

C-00062/4

Copyright © 2020 Freudenberg Oil & Gas Technologies. All rights reserved

Low Temperature

		OIL & GAS TECHNOLOGIES	
<p>Certificate of Test</p> <p>Freudenberg Oil & Gas Technologies' 13 5/8" x 5,000 psi NBR 162 Ultra annular packing unit was successfully tested for low temperature design validation at or under 40°F in accordance with API 16A, Fourth Edition, section 4.7.3.27 PR2 procedures and acceptance criterion.</p>			
<p>Product Details: FOGT 13 5/8" x 5,000 psi Ultra Annular Packing Unit NBR 162</p>			
Manufacturer:	Freudenberg Oil & Gas Technologies		
Part Number:	10108521-33		
Batch Number:	2013-2020/201144		
Compound Description:	NBR 162 Elastomer		
<p>Test Parameters</p>			
Validation Test Standard:	API 16A Fourth Edition PR2, Low Temperature Test		
BOP Type:	Annular, 13 5/8" x 5,000 psi		
BOP Model:	BOP Products Series 800 13-5/8" 5K		
BOP Serial Number:	B263-19/BR-008		
Wellbore Temperature, maximum:	4.3 °C	39.8 °F	
Temperature Class:	F	40 °F	
Wellbore Pressure, minimum:	347 bar	5028 psi	
Closing Pressure, maximum:	104 bar	1502 psi	
Test Medium:	Ethylene glycol/water 50/50		
Hold Duration:	10 minutes		
FOGT Work Order:	2020 072		
<p>Test Details</p>			
Test Performed by	Freudenberg Oil & Gas Technologies		
Test Location	Materials Development & Product Testing Lab 4535 Brittmoore Rd. Houston, TX 77041		
Internal Test Procedures	SOP-00128/1, in accordance with API 16A Fourth Edition, PR2		
Test Completion Date	June 15, 2020		
Test Results	No leakage during the hold period		
<p>Authorized by:</p>			
Michael LoGiudice			
			
Manager, HOU LAB Facility			

C-00063/1

Copyright © 2020 Freudenberg Oil & Gas Technologies. All rights reserved

API Q1 Certification

All Temperature Rated Ultra NBR 162 13-5/8" 5K SBOP Annular Packing Units are manufactured at the API Q1 and API-16A certified FO> facility located in Houston, TX.

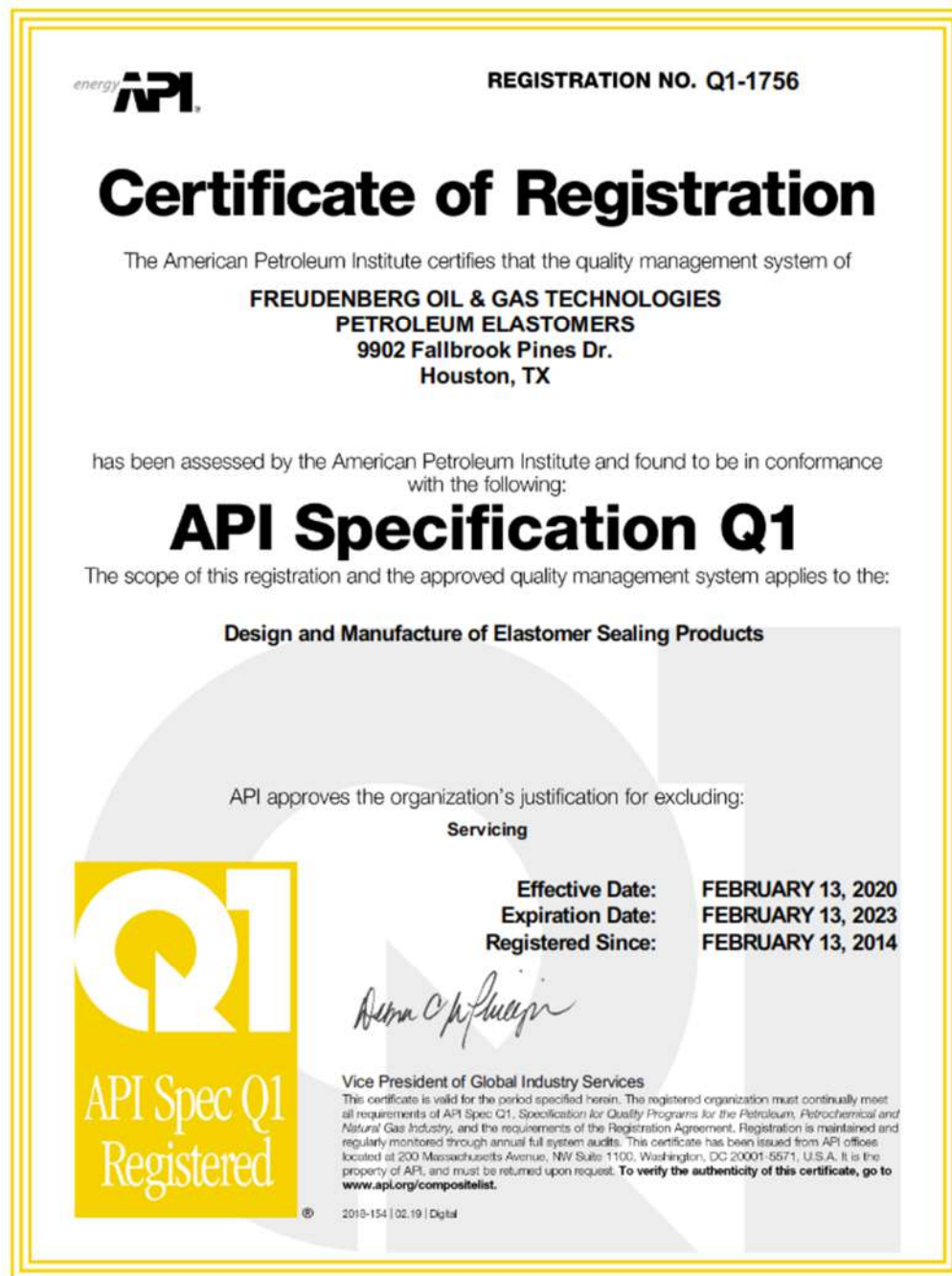

API 16A Certification

All applicable validation tests of the Temperature Rated Ultra NBR 162 13-5/8" 5K SBOP Annular Packing Units were performed to, and met or exceeded, all applicable API 16A test requirements. All tests were performed in OEM or CEM equipment.



2018-151 | Digital

Certificate of Authority to use the Official API Monogram
License Number: 16A-0429 **ORIGINAL**

The American Petroleum Institute hereby grants to
FREUDENBERG OIL & GAS TECHNOLOGIES
PETROLEUM ELASTOMERS
9902 Fallbrook Pines Dr.
Houston, TX

the right to use the Official API Monogram® on manufactured products under the conditions in the official publications of the American Petroleum Institute entitled API Spec Q1® and **API-16A** and in accordance with the provisions of the License Agreement.

In all cases where the Official API Monogram is applied, the API Monogram shall be used in conjunction with this certificate number: **16A-0429**

The American Petroleum Institute reserves the right to revoke this authorization to use the Official API Monogram for any reason satisfactory to the Board of Directors of the American Petroleum Institute.

The scope of this license includes the following: Annular Packing Units

QMS Exclusions: Servicing

Effective Date: FEBRUARY 13, 2020
Expiration Date: FEBRUARY 13, 2023

Vice President of Global Industry Services

To verify the authenticity of this license, go to www.api.org/compositelist.

Certificate of Quality

Temperature Rated Ultra NBR 162 13-5/8" 5K SBOP Annular Packing Units will be shipped with the required documentation including a FO> Certificate of Quality.

 FREUDENBERG INNOVATING TOGETHER	FREUDENBERG OIL & GAS TECHNOLOGIES	
<h1>Certificate of Quality</h1>		
<p>Freudenberg Oil & Gas Technologies (FO&GT)- Petroleum Elastomers (PE) certifies that the Freudenberg Temperature Rated Annular Packing Unit listed herein, has been manufactured and inspected in accordance with FO&GT standards.</p>		
<p>FO&GT – PE certifies this Freudenberg Temperature Rated Annular Packing Unit has passed the Factory Acceptance Test (FAT) and meets FO&GT design acceptance criteria.</p>		
Part Number:	
Serial Number:	
Description:	
Compound:	
Date Manufactured:	
Expiration Date:	
		
.....
Quality Assurance	Quality Inspector	Date
For service, call: +1 281 591-1500 (M - F from 8 a.m. - 5 p.m.) After hours, call: +1 713 397-0009		www.fogt.com
 Keep this document for reference!		Copyright © 2020 Freudenberg Oil & Gas Technologies. All rights reserved

