



Making life **EZI...**for Plumbers



EZIPEX CRIMPTM

WATER & GAS SOLUTIONS

CONTENTS

2	Overview
3	Application
4 – 8	Pipe
9	Fittings
10	Features & Benefits
11 – 15	Installation Considerations
16 – 18	Joining Instructions
19 – 24	EXIPEX™ Crimp Fitting Range
25	EZIPEX™ Crimp Tools
26 – 28	Notes
29	Warranty

Making life **EZI...**for Plumbers

Overview

The EZIPEX Crimp™ system was developed to satisfy the requirements of customers who were seeking an alternative to our existing EZIPEX Slide™ compression system.

One of the key requirements was the need for a quick and effective jointing method, combined with the peace of mind provided by the performance benefits of our EZIPEX™ pipe. It was also clear that customers had a definite preference to continue using our existing and already proven EZIPEX™ pipe. EZIPEX Crimp™ joins EZIPEX Slide™, EZIPEX Push™ and EZIPEX Gas™ to provide a total solution for all water and gas applications.

The EZIPEX™ product range is based on a premium quality cross-linked polyethylene pipe which is used in conjunction with either of our 3 available ranges of DZR brass fittings, Crimp, Push and Slide.

All installations should be carried out by an appropriately licensed tradesperson and in full accordance with the EZIPEX Crimp™ installation guidelines, the relevant Australian standards and any additional local authority requirements. When installed subject to the above conditions the EZIPEX Crimp™ system will provide years of trouble-free service.

Application

The EZIPEX Crimp™ system uses a crimping tool to produce a secure joint in a minimal amount of time. The crimping method guarantees a perfect seal every time, and eliminates the need for call backs to repair partially welded joints, etc.

EZIPEX Crimp™ Water fittings may be used in accordance with AS/NZS 3500 for water applications including:

- Hot and Cold Potable Water,
- Rainwater,
- Recycled Water (non-potable), and
- Hydronic Heating.

For optimum performance results please take the time to become familiar with the installation considerations outlined on Pages 11-15 in this booklet.

Pipe

EZIPEX™ pipe is a high quality PEX-a cross linked polyethylene pipe. In general terms polyethylene in its normal state is not capable of handling high pressure or temperature loads. However once subjected to the cross-linking process, its ability to handle these conditions is increased substantially.

EZIPEX™ pipe consists of an inner section of PEX-a material encased in an outer layer of tough HDPE.



EZIPEX™ also offers a pipe specifically for use in hydronic heating. This pipe is identified by its bright orange colour. EZIPEX™ orange pipe is a similar construction to the standard EZIPEX™ pipe. However, it also incorporates a layer of EVOH material which acts as an oxygen barrier, thus preventing the entry of additional oxygen into the sealed heating system.



EZIPEX™ pipe is available in the following sizes: DN16, DN20, DN25 and DN32, in either coil form or straight lengths.



EZIPEX™ pipe is warranted for use with “potable water” and “glycol solutions” only. Contact your local EZIPEX™ supplier for more information and applications for use with other fluids.

EZIPEX™ pipe - standard supply units

Nom pipe size	Straight lengths (all)	Coil length (black)	Coil length (red)	Coil length (green)	Coil length (lilac)	Coil length (orange)
16mm	5m	50m 100m	50m 100m	50m 100m	50m	200m
16mm (In Conduit)		50m	50m			
20mm	5m	50m 100m	50m 100m	50m 100m	50m	
20mm (In Conduit)		50m			50m	
25mm	5m	50m	50m	50m		
32mm	5m	25m		25m		
16mm (Conduit only)		50m				
20mm (Conduit only)		50m				
25mm (Conduit only)		50m				
32mm (Conduit only)		25m				

The EZIPEX™ pipe is colour coded to assist the installer in avoiding cross connections.

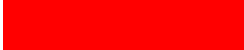
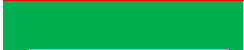

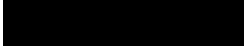
	BLACK	Hot & cold potable water
	RED	Hot water
	GREEN	Rainwater
	LILAC	Recycled water (non-potable)
	ORANGE	Hydronic heating
	CONDUIT	In/under slab hot & cold water

EZIPEX™ pipe dimensions

Nom Size	Mean OD (mm)	Mean Wall Thickness (mm)
16mm	16.15	2.20
20mm	20.15	2.80
25mm	25.15	3.50
32mm	32.15	4.40

Performance

The use of EZIPEX™ pipe provides users with many advantages over traditional piping materials. It has excellent flexibility, offers a high degree of resistance to damage caused by freezing, offers excellent pressure and temperature resistance, is lightweight and also has low noise and heat transmission qualities. EZIPEX™ pipe provides very low levels of friction loss and therefore can often save users the need to upsize piping when installing long runs. As jointing methods are mechanical, it does not require the use of solvents. Nor does it require soldering, welding or brazing.

EZIPEX™ pipe heat & pressure performance

AS/NZS 2492

Recommended working pressure relative to pipe material temperature

Temp (°C)	20	40	60	70
Pressure (Kpa)	2000	1800	1500	1330

Cross-section

Black, Red, Green, Lilac pipe

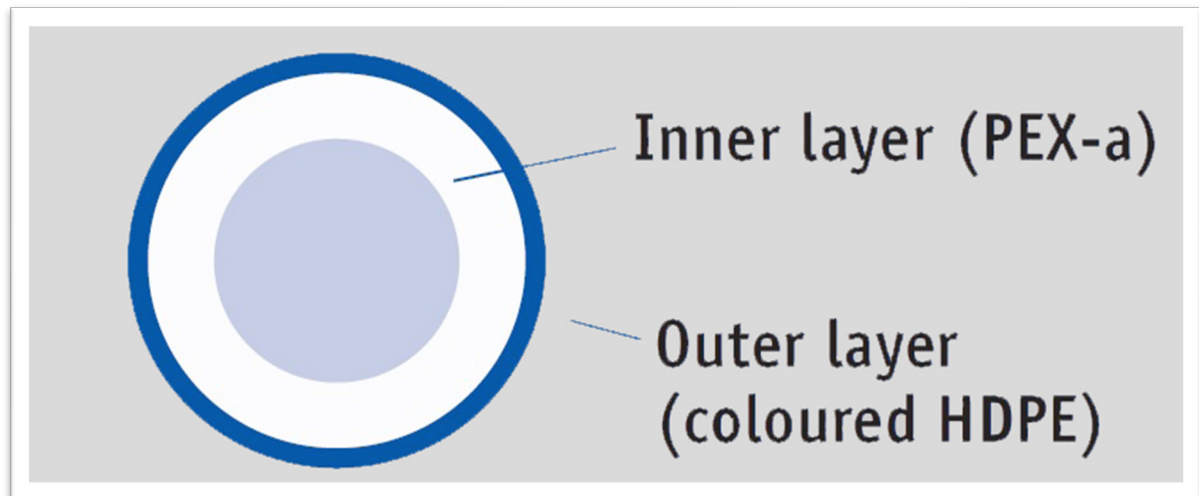

1. Inner layer: combination of HDPE & cross linking agent.
2. Outer layer: HDPE compound. (Note that Red & Green pipe has two outer layers to meet opacity requirements.)

Orange pipe

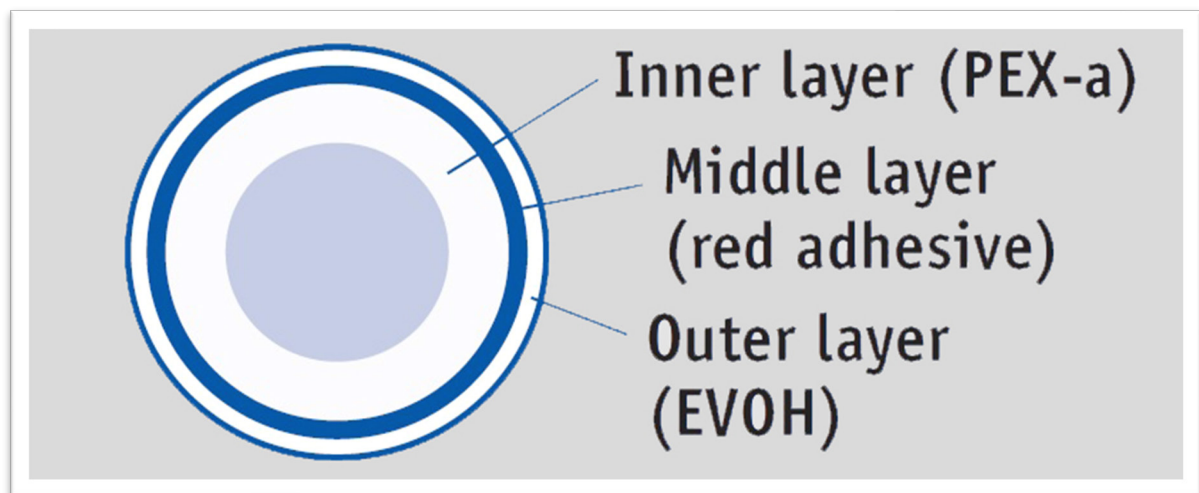

1. Inner layer: the same PEX-a layer as standard EZIPEX™ pipe.
2. Middle layer: coloured adhesive to bind internal PEX-a layer to the external EVOH layer(<0.13mm).
3. Oxygen barrier (<0.01mm). Clear outer layer which prevents oxygen from permeating through the pipe from the outside atmosphere.

Fittings

The bodies of EZIPEX Crimp™ fittings are manufactured from DZR brass whilst the crimp rings are of a high-quality copper construction to provide exceptional resistance to corrosion.

All EZIPEX Crimp™ fittings come with sleeve protection plugs to protect the integrity of the crimp ring during shipping and storage. Other systems without these plugs are often prone to problems caused by out-of-shape crimp rings. These sorts of problems can slow down the installation process considerably.

EZIPEX Crimp™ fittings are manufactured with longer barbs and crimp rings than many similar products – also adding to the integrity of each joint.

All EZIPEX Crimp™ fittings are manufactured and certified to AS/NZS 2537 – mechanical joint fittings for use with EZIPEX PEX-a pipe for hot & cold water applications.

EZIPEX Crimp™ fitting dimensions

Nom Size	Mean Bore (mm)
16mm	8.5
20mm	11.2
25mm	14.2
32mm	19.0

Features and Benefits

Crimp Jointing Method	<ul style="list-style-type: none">• Fast• Secure• Simple to use• Less time on the job• Less capital outlay on tooling• Internal sealing method reduces leaks due to scratched pipe
Stock Consolidation	<ul style="list-style-type: none">• Same pipe for EZIPEX Push™, EZIPEX Slide™ & EZIPEX Crimp™• One pipe 3 systems
Flame-free Assembly	<ul style="list-style-type: none">• Increased safety• No need for gas cylinders or Hot Works permits• Reduced costs on welding consumables
Size Range DN15 – DN32	<ul style="list-style-type: none">• Fittings available for most tasks
Acoustics	<ul style="list-style-type: none">• Low noise transmissions in PEX-a pipe• Quieter, reduced water hammer

Installation Considerations

EZIPEX Crimp™ should always be installed in compliance with AS/NZS 3500. Most installation requirements can be sourced from this document.

Proximity to flame / external heat sources

The EZIPEX Crimp™ system should not be installed in positions where it is likely to be exposed to a naked flame. If it is, there's a danger the pipe could ignite and continue to burn even after the source of the flame is extinguished. In accordance with AS/NZS 3500 all plastic pipes for water supply must be protected from excessive ambient heat.

Solar Water Heaters & Other Uncontrolled Energy sources

In accordance with AS/NZS 3500 plastic pipes (EZIPEX™ Pipe) shall not be used between solar collectors and heated water containers, and / or used between an uncontrolled heat source and a heated water tank.

Thermal expansion

EZIPEX™ pipe has a thermal expansion rate of approximately 1.5mm per metre for every 10°C change in temperature. This expansion or contraction should be taken into consideration for any installation and the appropriate allowances made in the pipe layout or fixing positions. Care should be taken not to pull the pipe tightly between fixed points during installation as the pipe may later contract causing excessive tensile force to any joints. This could cause a joint failure.

Heat & Pressure performance

As with all plastic pipe systems, the ability of the pipe to withstand pressure decreases as the pipe temperature increases. *(Refer to table on page 7)*

Protection from physical damage

Due care should be taken to protect pipe and fittings from any physical damage both prior to, during and after installation. Possible causes of physical damage may include (but are not limited to) sharp edges or implements, machinery, rodents, excessive heat, long term UV exposure, radiation, mechanical forces, corrosive agents and high levels of chlorine and other chemicals that may have a detrimental effect on the piping system. EZIPEX™ brass fittings should not come in contact with treated pine.

Both during and after installation, the product should not be damaged by grouting or stress caused by concrete stress cracks or any other external force.

Framework Penetrations

Where EZIPEX™ pipe penetrates timber or metal framework, appropriate precautions should be taken to protect it from damage. Holes should be sized to allow for longitudinal movement, expansion and contraction of pipe whilst still securing the pipe adequately. Suitable grommets or sleeves should be used in metal frames to protect the pipe from abrasion.

Pipe Bending

Do not apply bending forces to joints which have already been completed. Finish all bending operations prior to installing the fitting.

Due care should be taken during bending to ensure that the pipe is not damaged or kinked. If you do encounter a kinked or damaged section of pipe, it should be cut out and replaced as a precaution. The use of bend supports is recommended where required.

EZIPEX™ pipe can be bent easily by hand. The radius of the bend should be not less than 8 times the diameter of the pipe.

Minimum Bending Radius

Nom Size	Min Bending Radius (mm)
16mm	130
20mm	162
25mm	202
32mm	258

Clipping

In accordance with AS/NZS 3500, fixing spacing should be observed for both horizontal and vertical pipe runs as outlined on the table below.

Clipping should be by way of a recognised fixing which complies with the requirements of AS/NZS 3500. This excludes things such as bent-over nails, tie wire, pierced metal strapping, etc. It is recommended that EZIPEX™ pipe is installed using a PEX Clip to ensure secure fastening of pipe in a manner that will not exert stress on the fittings caused by thermal expansion and contraction of pipe.

Clip Spacing Table

Nom Size	Vertical Run Spacing (m)	Horizontal Run Spacing (m)
16mm	1.2m	0.6m
20mm	1.4m	0.7m
25mm	1.5m	0.75m
32mm	1.7m	0.85m

Underground

Pipe should be buried with a minimum cover of 450mm. Marker tape should be installed approximately 150mm above the pipe. Additional precautions, such as wrapping of the pipe, should be taken in areas where aggressive soil conditions are known to exist or where it may be a requirement of the local certifying authority. The use of “Blue Metal” or “Crusher Dust” as a backfill material is to be avoided. Ground needs to be inspected to ensure it is not contaminated prior to burial of the pipe, and care should be taken to ensure that post- installation contamination does not occur.

When being buried beneath a building, the pipe should be free of joints.

Chases, In-Slab, Under-floor

Where EZIPEX™ pipe is installed in chases or cast in slabs the installation must be in accordance with both AS/NZS 3500 and any other relevant building regulations or standards.

A convenient and cost effective solution for these applications is the EZIPEX™ pipe pre-sleeved in durable and flexible polyethylene corrugated conduit – available as part of the EZIPEX™ piping range.

UV Exposure

All EZIPEX™ pipe should be protected from long term exposure to UV by way of either lagging or enclosing in a conduit.

Note: Additional thermal lagging may also be required to protect any of the pipes from temperature extremes.

Hot Water Ring Mains

In larger homes and commercial buildings hot ring mains are commonly used to decrease the time it takes for hot water to be delivered to the various outlets, especially those that are a significant distance from the hot water heater. Given the continuous high temperature and circulation of water within the pipe work these are demanding applications for all piping systems, including PEX. To ensure the service life of PEX used in the flow and return pipework in a recirculating ring main the following installation practices and operating parameters must be met.

- Maximum water temperature of 60°C (measured, not set point).
- Maximum water pressure of 500kPa (as per AS/NZ3500)
- Maximum water velocity to the requirement of AS 3500 for non-metallic piping.
- Circulation time is to be limited to 12 hours per 24-hour period by means of timer operated pump.
- The pipe work must be lagged, and it is recommended to use a thermostat-controlled recirculation pump.

Testing

In all installations at the completion of rough-in, pressure testing must be carried out in accordance with AS/NZS 3500 for water installations and in addition to any other local regulations or requirements.

During testing, all joints should be checked for leaks, prior to burying or concealing the EZIPEX Crimp™ system.

Joining instructions

1. Cut pipe

Cut pipe to desired length. Cut should be square and free from any swarf or burrs. Use REMS pipe cutter or similar blade type cutter. Do not use a hacksaw as this creates excessive swarf.



2. Check assembly

Ensure that the copper crimp ring and plastic ring retainer are assembled correctly onto the fitting. Both can be pushed on by hand if they have moved away from the fitting shoulder. Witness holes should be located toward the rear of each barb.

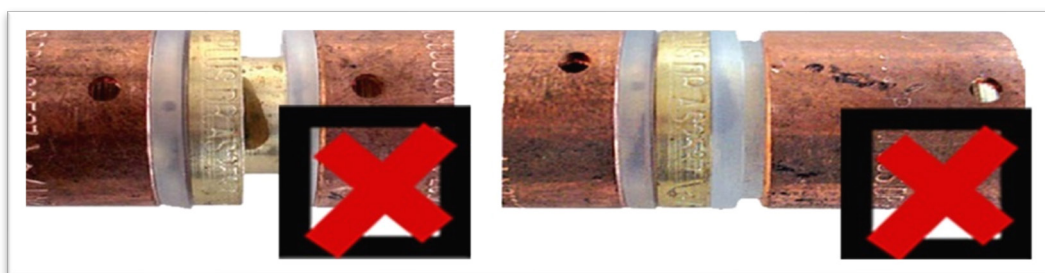

3. Insert pipe

Slide pipe onto fitting until it reaches the depth stop. Pipe should be fully visible through the witness holes on the crimp ring.



4. Crimp tool positioning

Position crimping tool evenly over the copper crimp ring. You should leave a similar distance between the outside of the jaw and the end of the crimp ring at both ends. Crimp tool should be placed at 90° to the pipework.



5. Crimp

Fully close jaws of the crimping tool to compress the copper crimp ring. Do not compress the plastic ring retainer.



6. Check crimp ring

Finally, and most importantly, check the crimp ring dimension by placing the crimp gauge over the centre of the indented ring on the crimp sleeve. On a correctly crimped fitting the crimp gauge should pass freely over the crimp ring at this point.



Pressure test

At completion, carry out pressure testing. All testing should be undertaken in accordance with AS/NZS 3500 (for water installations) and/or in addition to any other local regulations or requirements.

EZIPEX Crimp™ Fittings

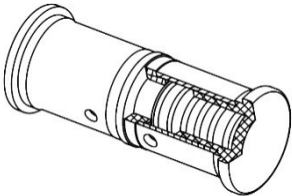
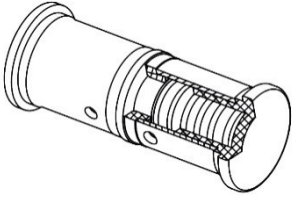
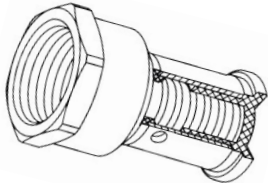
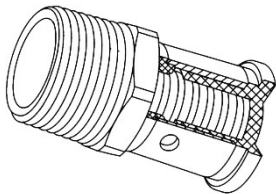
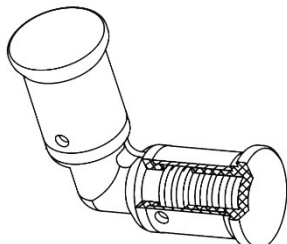
PRODUCT DESCRIPTION	SIZE	PART #
#1 STRAIGHT COUPLING 	DN16	335096
	DN20	335097
	DN25	335098
	DN32	335099
#1R REDUCING COUPLING 	DN20 X DN16	335102
	DN25 X DN16	335103
	DN25 X DN20	335104
	DN32 X DN25	335105
#2 CONNECTOR 	DN16 X 15BSPF	335149
	DN16 X 20BSPF	335144
	DN20 X 15BSPF	335150
	DN20 X 20BSPF	335151
	DN25 X 20BSPF	335301
	DN25 X 25BSPF	335305
	DN32 X 25BSPF	335306
#3 CONNECTOR 	DN16 X 15BSPM	335154
	DN16 X 20BSPM	335152
	DN20 X 15BSPM	335155
	DN20 X 20BSPM	335156
	DN25 X 20BSPM	335158
	DN25 X 25BSPM	335159
	DN32 X 25BSPM	335161
	DN32 X 32BSPM	335162
#12 ELBOW 	DN16	335108
	DN20	335109
	DN25	335110
	DN32	335111

EZIPEX Crimp™ Fittings

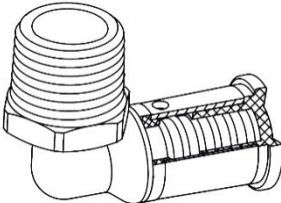
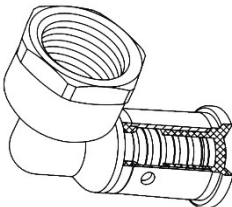
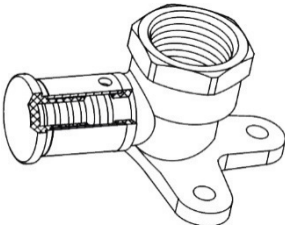
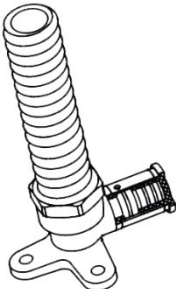
PRODUCT DESCRIPTION	SIZE	PART #
#13 ELBOW 	DN16 X 15BSPM	335163
	DN20 X 15BSPM	335164
	DN20 X 20BSPM	335165
	DN25 X 25BSPM	335166
#14 ELBOW 	DN16 X 15BSPF	335169
	DN20 X 15BSPF	335170
	DN20 X 20BSPF	335171
#15BP ELBOW 	DN16 X 15BSPF	335178
	DN20 X 15BSPF	3351770
	DN20 X 20BSPF	335177
	DN16 X 15BSPF - Low Inlet	335178L
	DN20 X 15BSPF - Low Inlet	3351770L
	DN20 X 20BSPF - Low Inlet	335177L
#19BP ELBOW 	DN16 X 15BSPM X 75mm Long	335179H
	DN16 X 15BSPM X 90mm Long	335176
	DN16 X 15BSPM X 150mm Long	335175
	DN16 X 15BSPM X 200mm Long	335174
	DN20 X 15BSPM X 95mm Long	335173
	DN20 X 20BSPM X 200mm Long	335181
	DN16 X 15BSPM X 65mm Long - Low Inlet	335179L
	DN16 X 15BSPM X 90mm Long - Low Inlet	335176L
	DN16 X 15BSPM X 150mm Long - Low Inlet	335175L
	DN16 X 15BSPM X 200mm Long - Low Inlet	335174L
	DN20 X 15BSPM X 95mm Long - Low Inlet	335173L
	DN20 X 20BSPM X 200mm Long - Low Inlet	335181L

EZIPEX Crimp™ Fittings

PRODUCT DESCRIPTION	SIZE	PART #
---------------------	------	--------

#24 TEE EQUAL

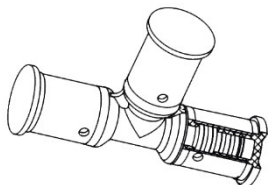

DN16	335114
DN20	335115
DN25	335116
DN32	335117

#25 TEE RED. BRANCH

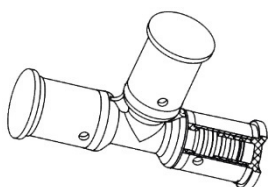

DN20 X DN20 X DN16	335120
DN25 X DN25 X DN20	335122
DN25 X DN25 X DN16	335121
DN32 X DN32 X DN25	335123

#26 TEE RED. END

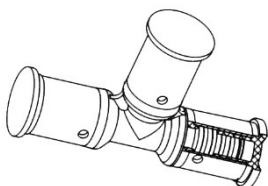

DN20 X DN16 X DN20	335126
DN25 X DN20 X DN25	335128
DN25 X DN16 X DN16	335233

#27 TEE RED. END & BRANCH

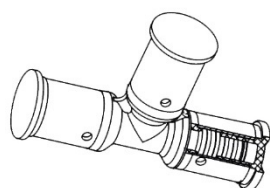

DN20 X DN16 X DN16	335132
DN25 X DN20 X DN20	335136

#30 TEE FI CENTRE

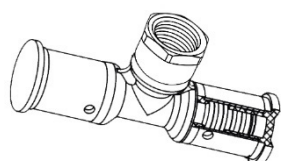

DN16 X DN16 X 15BSPF	335230
DN20 X DN20 X 15BSPF	335231
DN20 X DN20 X 20BSPF	335232

EZIPEX Crimp™ Fittings

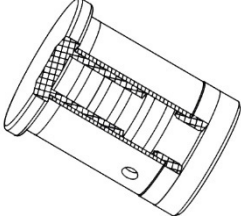
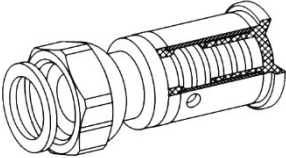
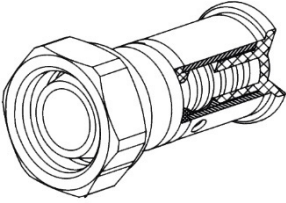
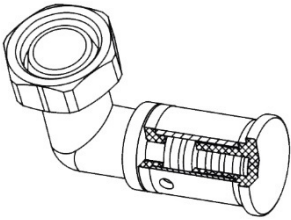
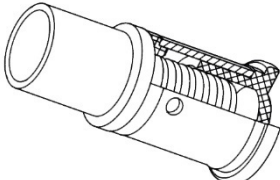
PRODUCT DESCRIPTION	SIZE	PART #
#61 STOPPER 	DN16	335204
	DN20	335205
	DN25	335206
	DN32	335207
#62 STRAIGHT TAP CONNECTOR - FLAT SEAT + WASHER 	DN16 X 15BSPF	335183
	DN20 X 20BSPF	335184
#62 STRAIGHT TAP CONNECTOR - CONE SEAL 	DN16 X 15BSPF	3351831
	DN20 X 20BSPF	3351841
#63 BENT TAP CONNECTOR 	DN16 X 15BSPF	335185
	DN20 X 20BSPF	335186
CONNECTING BARB x CU SPIGOT 	DN16 X 15CU	335145
	DN20 X 20CU	335146
	DN25 X 25CU	335147
	DN32 X 32CU	335148

EZIPEX Crimp™ Fittings

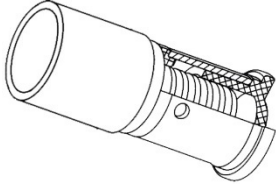
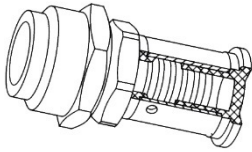
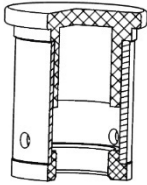
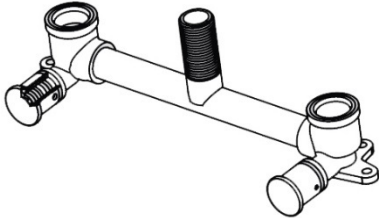
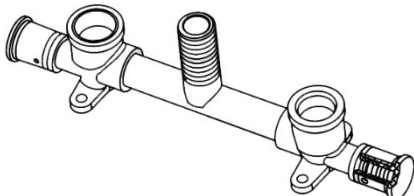
PRODUCT DESCRIPTION	SIZE	PART #
CONNECTING BARB x CU SOCKET 	DN16 X 15CU	335215
	DN20 X 20CU	335216
	DN25 X 25CU	335217
	DN32 X 32CU	335218
FLARED COPPER COMPRESSION UNION 	DN16 X 15FL	335094
	DN20 X 20FL	335095
CRIMP RING ASSY ONLY 	DN16	335090
	DN20	335091
	DN25	335092
	DN32	335093
BATH/LAUNDRY ASSEMBLY RIGHT ANGLE 	200mm Centres	335194
	300mm Centres	335193
	200mm Centres – Low Inlet	335194L
	300mm Centres – Low Inlet	335193L
BATH/LAUNDRY ASSEMBLY STRAIGHT 	300mm Centres	335192
	300mm Centres – Low Inlet	335192L

EZIPEX Crimp™ Fittings

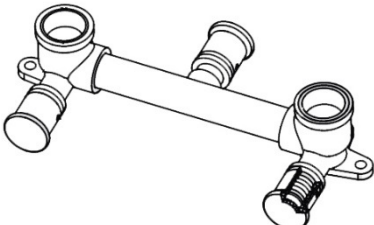
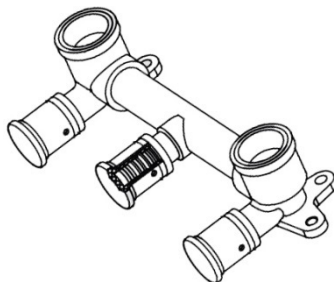
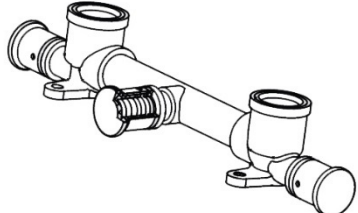
PRODUCT DESCRIPTION	SIZE	PART #
SHOWER ASSEMBLY RIGHT ANGLE 	150mm Centres	335195
	200mm Centres	335199
	150mm Centres – Low Inlet	335195L
	200mm Centres – Low Inlet	335199L
SHOWER ASSEMBLY RIGHT ANGLE BARBS UP 	150mm Centres	335197
	200mm Centres	335198
	150mm Centres – Low Inlet	335197L
	200mm Centres – Low Inlet	335198L
SHOWER ASSEMBLY STRAIGHT 	150mm Centres	335196
	150mm Centres – Low Inlet	335196L

EZIPEX Crimp™ Tools



Rems Mini Press ACC- For EZIPEX Crimp sizes DN16 to DN32

Super light, super small, and super handy. With automatic circuit control. Secure crimping in seconds. Automatic locking of pressing tongs. Assortment of REMS pressing tongs for all EZIPEX™ systems.



Rems Power Press ACC- For EZIPEX Crimp sizes DN16 to DN32

Compact, robust, job site proven. Small in size, slender design. Works anywhere: free-hand, overhead, in confined areas. Ideal weight distribution for single handed operation. Automatic locking of pressing tongs. Assortment of REMS pressing tongs for all EZIPEX™ systems.



Manual Crimp Tool - For EZIPEX Crimp sizes DN16 to DN32

For alternative tools, see your local EZIPEX Crimp™ distributor...or visit www.ezipex.com.au

Disclaimer

Information provided in this publication is intended to be of a general nature only and is provided as a guide. Installation requirements may vary across different product applications or in different jurisdictions. Information provided does not in any way override that contained in the relevant Australian Standards for either product or installation practices.

Notes

20 horizontal grey bars for taking notes.

Blank lined area for notes, consisting of 20 horizontal grey bars.

Notes

20 horizontal grey bars for taking notes.



25 Year Warranty

This product is supplied with a 25-year warranty against any manufacturing defects. The period of the Warranty commences on the date of sale and ends on the anniversary of the date of sale. Any defective product will be repaired or replaced free of charge.

Warranty Conditions

- Installation must have been carried out by a licensed plumber and gasfitter.
- Failure is due to a fault in the manufacture of the product.
- Installation of the product has been in accordance with the installation instructions as per the current (at time of installation) EZIPEX™ Technical Manual.
- Installation must be in full accordance with the relevant local and National Plumbing codes and appropriate Australian Standards (AS/NZS 3500).
- The system in which the product is installed must not be operated at temperatures and or pressures that exceed the printed rating on the appropriate specification sheet.
- This warranty does not extend to failure or defect caused by normal wear and tear, mechanical overload, paint, adhesives, abrasion, corrosion or over pressurization.
- No liability will be accepted for loss of profits, loss of revenue, loss of use, loss of contracts, loss of production or any other consequential loss or damage.

Claim Procedure

- This Warranty is offered by the manufacturers of the EZIPEX™ pipe and fittings and the Plumbing Plus Merchant (**Merchant**) from whom you purchased the product. The Merchant involved should be notified of any potential claim immediately. Proof of purchase is required to validate the warranty period and if this is not available, the warranty period shall default to the date of manufacture for each product. The product needs to be inspected by an authorized representative of the manufacturer within 30 days of the alleged product failure.
- To be entitled to claim under this Warranty, you must send a Warranty Claim Form to the Merchant.
- Should product be returned, a sufficient length of pipe must be supplied so that all the pipe markings are visible. Should a fitting be returned, it must be supplied with the pipe still attached with sufficient length of pipe to show the markings.
- If the Merchant needs to return the goods to the manufacturer for assessment or repair, the Merchant will arrange delivery and bear the associated costs.
- The manufacturer and the Merchant also reserve the right to engage a nominated outside agent to assess any faulty product before honouring any warranty claim.
- Once a reasonable pre-approved amount is confirmed in writing by the manufacturer, repairs can begin.
- Any repairs or replacement undertaken without the manufacturer's or the Merchant's approval will not be covered by this Warranty.

Exclusions

Plumbing Plus BKL Pty. Ltd. is not a party to this Warranty Agreement.

Australian Consumer Law

Our goods come with guarantees that cannot be excluded under the Australian Consumer Law (**ACL**). For instance, you may be entitled to a replacement or refund or entitled to have the goods repaired or replaced if they are defective.



WaterMark

Making
life **EZI...**
for
Plumbers



TECHNICAL MANUAL