

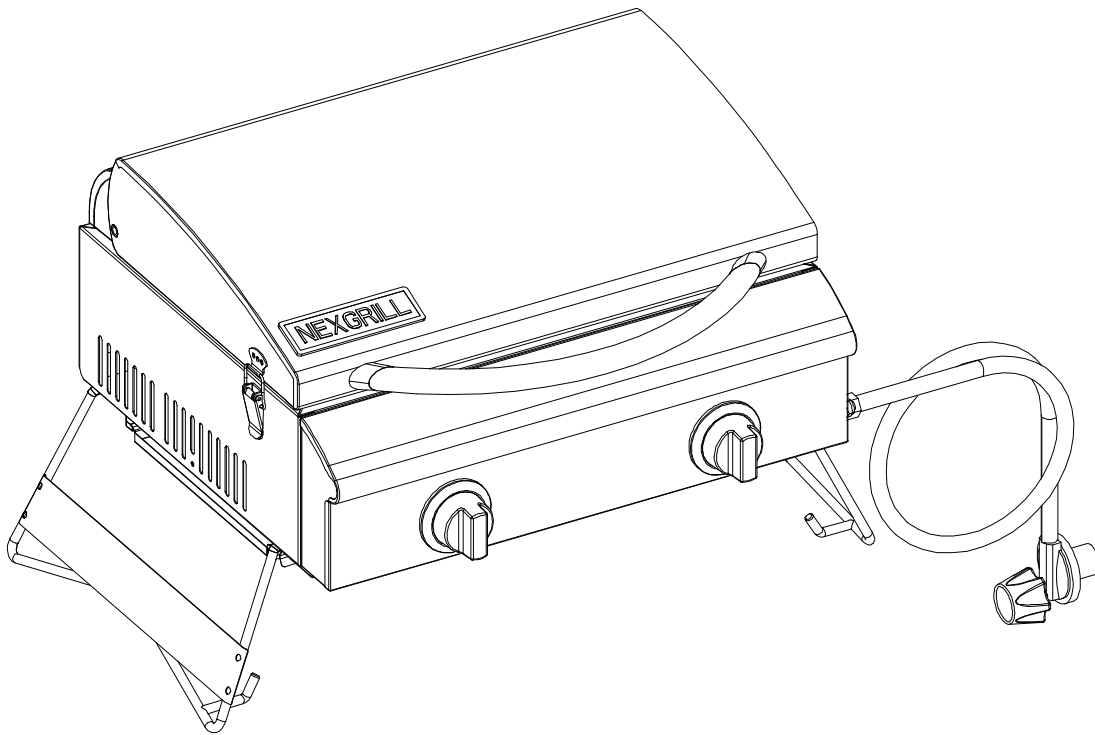

OUTDOOR TABLE TOP GAS GRILL

MODEL #820-0015

Type of gas: Butane(G30), Propane(G31)



CE 1008-11

Manual Code # **19000374A0**

- This **instruction** manual contains important information necessary for the proper assembly and safe use of the appliance.
- Read and follow all warnings and instructions before assembling and using the appliance.
- Follow all warnings and instructions when using the appliance.
- Keep this manual for future reference.



Questions, problems, missing parts? Before returning to your retailer, call our customer service department at **United Kingdom 02392 322880**.

19000374A0

TECHNICAL INFORMATION

MODEL #	820-0015			
DESCRIPTION	Two burners table top gas grill			
TOTAL HEAT INPUT	5.9KW			
GAS CATEGORY	.. I _{3+(28-30/37)}	.. I _{3B/P(30)}	.. I _{3B/P(37)}	.. I _{3B/P(50)}
TYPES OF GAS	G31	G30	G30	G30
GAS PRESSURE	37mbar	29mbar	37mbar	50mbar
INJECTOR SIZE	0.85mm	0.85mm	0.80mm	0.76mm
FOR USE OUTDOORS ONLY AND IN WELL VENTILATED AREAS				
READ THE INSTRUCTION BEFORE USING THE APPLIANCE				
WARNING: ACCESSIBLE PARTS MAY BE VERY HOT. KEEP YOUNG CHILDREN AWAY				
This appliance must kept away from flammable materials during use				
Do not move the appliance during use				
Turn off the gas supply at the gas cylinder after use				
Any modification of the appliance may be dangerous				
Country of Destination:				
I _{3+ (28-30/37)} for BE, CH, CY, CZ, ES, FR, GB, GR, IE, IT, LT, PT, SI, SK and TR				
I _{3B/P(30)} for BE, BG, CY, CZ, DK, EE, FI, FR, GB, GR, HR, HU, IT, LT, MT, NL, NO, RO, SE, SI, SK, and TR				
I _{3B/P(37)} for PL				
I _{3B/P(50)} for AT, CH, CZ, DE, FR and SK				
Appliance manufactured by: Nexgrill Industries, Inc, 5270 Edison Avenue Chino, CA 91710				

TABLE OF CONTENTS

Technical Information.....	2	Installation Instructions.....	9
Table of contents and Warning.....	3	Operation Instructions.....	12
Safety Information.....	4	Care and Maintenance.....	13
Package Contents List.....	6	Trouble Shooting.....	14
Preparation.....	6	Replacement Parts List.....	15
Assembly Instructions.....	7	Warranty.....	16



DANGER

If you smell gas:

- 1. Shut off gas to the appliance.**
- 2. Extinguish any open flame.**
- 3. Open lid.**
- 4. If odour continues, keep away from the appliance and immediately call your gas supplier or local fire department.**

Failure to follow these instructions could result in fire or explosion, which could cause property damage, personal injury or death



DANGER

- 1. Never operate this appliance unattended.**
- 2. Never operate this appliance within 10 ft (3 m) of any structure, combustible material or other gas cylinder.**
- 3. Never operate this appliance within 25 ft (7.5 m) of any flammable liquid.**
- 4. Do not fill cooking vessel beyond maximum fill line.**
- 5. Heated liquids remain at scalding temperatures long after the cooking process. Never touch cooking appliance until liquids have cooled to 115°F (45°C) or less.**
- 6. This appliance is not intended for and should never be used as a heater.**
- 7. If a fire should occur, keep away from the appliance and immediately call your fire department. Do not attempt to extinguish an oil or grease fire with water.**

Failure to follow these instructions could result in fire, explosion or burn hazard, which could cause property damage, personal injury or death.



SAFETY INFORMATION

Please read the following instructions carefully before attempting to assemble, operate or install the product. Failure to follow these instructions may result in serious bodily injury and/or property damage. If you have questions regarding the product please call customer service at [United Kingdom 02392 322880](tel:02392322880).

1. Table top grill is for outdoor use only. Grill should be operated in a well-ventilated space. Never operate in an enclosed space, garage or building. Your grill is not intended to be installed in or on recreational vehicles and / or boats .
2. Heated liquids remain at scalding temperatures long after the cooking process. Do not touch the cooking appliance until liquids have cooled to 115°F (45°C) or less.
3. Do not install or use grill within **24 inches (61cm)** of combustible materials from back and sides of grill. Grill shall not be located under overhead surfaces (closed carport, garage, porch, patio) that can catch fire.
4. Never attempt to attach this grill to the self-contained LP gas system of a camper trailer or motor home.
5. It is the responsibility of the assembler/owner to assemble, install and maintain gas grill. Do not let children and pets operate or play near your table top grill. Failure to follow these instructions could result in serious personal injury and/ or property damage.
6. Open lid before lighting grill. When grill is not in use, turn off control knob on LP gas cylinder.
7. Carefully follow instructions in this manual for proper assembly and leak testing of your grill. Do not use grill until leak checked. If leak is detected at any time, it must be stopped and corrected before using grill further.
8. Appliance area should be kept clear and free from combustible materials, gasoline, bottled gas in any form and other flammable vapors and liquids. Do not obstruct flow of combustion and ventilation air.
9. Never try to light grill with lid closed! Buildup of gases is very dangerous and could cause an explosion.
10. Keep any electrical cord of fuel supply hose away from any heated surfaces.
11. Propane/butane is a flammable gas and improper handling may result in explosion and/or fire and serious accident or injury.
12. This appliance will be during and after use. Use insulated oven mitts or gloves for protection from hot surfaces or splatter from cooking liquids.
13. Do not leave your grill unattended while in operation.
14. Do not use while under the influence of drugs or alcohol.
15. Do not store any spare LP (propane/butane) cylinder, full or empty, under or near your grill.
16. Appliance is not intended for commercial use or rental.
17. The cylinder must be disconnected when the appliance is not in use.

NATURAL HAZARD • SPIDERS

FACT: Sometimes spiders and other small insects climb into the burner tube. The spiders spin webs, build nests and lay eggs. The webs or nests can be very small, but they are very strong and can block the flow of gas. Clean burner prior to use after storing, at the beginning of grilling season or after a period of one month not being used.





SAFETY INFORMATION

The Fuel System

Gas grills are used safely by millions of people when following simple safety precautions.

The items in the fuel system are designed for operation with this grill. They must not be replaced with any other brand. (See parts list for replacement items.)

GAS BURNER: The gas burner is constructed of stainless steel and should not require maintenance other than inspection for insects/nests inside the air intake slots.

LP GAS REGULATOR CAUTION

The gas pressure regulator provided with this appliance must be used. This regulator is equipped with the required orifice and is set for the required outlet pressure for this appliance. This combination of orifice size and pressure regulation specifications provides the cooking performance intended by Table Top Grill. This barbecue is set to operate a 29mbar regulator with butane gas, a 37mbar regulator with propane gas, a 50mbar regulator with butane gas, a 37mbar regulator with butane gas. Substitution of regulator by any other device or any other manufacturer is dangerous and could result in serious injury.

FUEL SUPPLY HOSE

The hose connected regulator provided with this appliance is **1 meter long**. Keep the fuel hose away from any heated surface (s).

GAS FUEL: Warning – propane/butane is a flammable gas. Improper handling may result in an explosion and/or fire and serious accident or injury. Your grill is designed to operate with **propane/butane**(LP) gas only and is equipped with the proper orifice for **propane/butane** gas.

Caution: Make certain adequate ventilation is available when using your grill. The gas cylinder may be stored outside in a well-ventilated area out of the reach of children when the grill is not in use.

The LP gas cylinder shall be used only outdoors in a well-ventilated space and not in a building, garage, or any other enclosed area. The Table Top Grill may be stored indoors if the LP gas cylinder is removed and stored outdoor. The LP gas cylinder (not included) is threaded for connection directly to the gas regulator supplied with this appliance. Care should be taken when threading the cylinder to the regulator to engage threads correctly to achieve the proper and intended connection. When disconnecting or connecting the gas cylinder, be careful that the regulator does not strike the grill, the ground, or any other surfaces. Replace the protective cap over the threaded cylinder connection when removed from grill. If any difficulty occurs when connecting or disconnecting the cylinder to the regulator assembly, contact your local gas supplier for assistance.

When **reconnecting** the LP gas cylinder to the regulator, be sure to hand-tighten until snug. This connection should be inspected for damage and leak tested after each **reconnection**.

To Do a Leak Test, make a soap solution of one part liquid detergent and one part water. You will need a spray bottle, brush, or rag to apply the solution to the fitting. Bubbles indicate leaks.

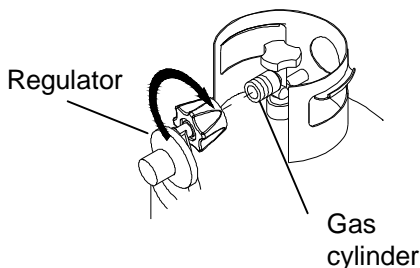

Check all gas supply fittings for leaks before each use. Do not use the grill until all connections have been checked and do not leak.

PACKAGE CONTENTS

Part	Description	Quantity
1	Grill	1 set
2	Foldable leg	2 pcs
3	Knob	2 pcs
4	Cooking grid with hole	1 pc
5	Flame tamer	2 pcs
6	Grease tray	1 pc

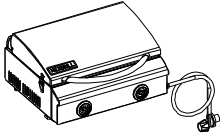

1

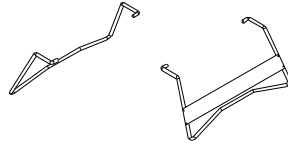

2



3

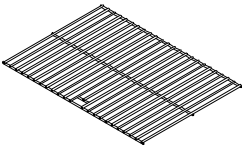

4

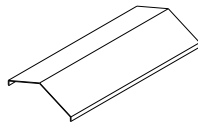

5

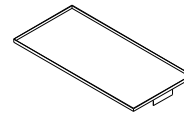

6

PREPARATION

Before beginning assembly, installation or operation of product, make sure all parts are present. Compare parts with package contents list and diagram above. If any part is missing or damaged, do not attempt to assemble, install or operate the product. Contact customer service for replacement parts.

- Your Table Top Grill is pre-assembled. The only assembly required is to connect the foldable legs and place the flame tamers, cooking grid and control knobs into the grill.
- Estimated Assembly Time: 5 minutes.

ASSEMBLY INSTRUCTIONS

1. Remove all the packing materials and move grill close to a desired location.
2. Take out the two foldable legs, insert them into the bracket A, B,C,D under firebox as shown in Fig.1.

Note: Expand (using two hands) the legs and they will slide into the brackets as shown.

Fig. 1

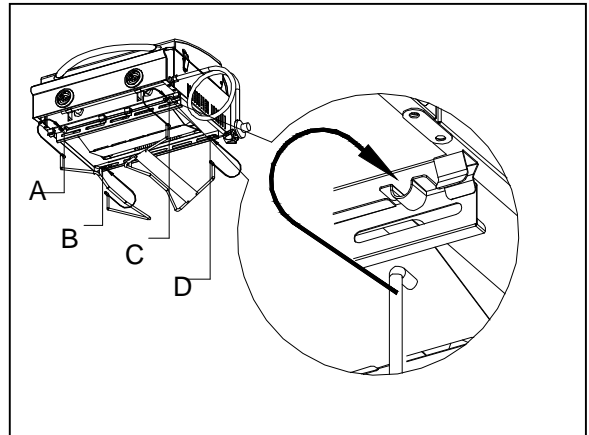

3. Unfold the two legs and insert the grease tray as shown in Fig. 2.

Fig. 2

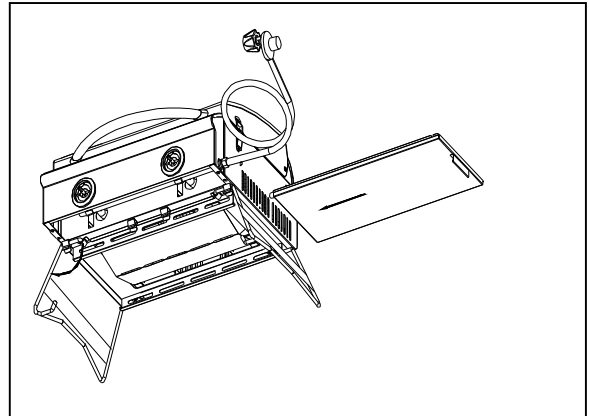

4. Place the flame tamers and cooking grid in the firebox as shown in Fig. 3.

Fig. 3

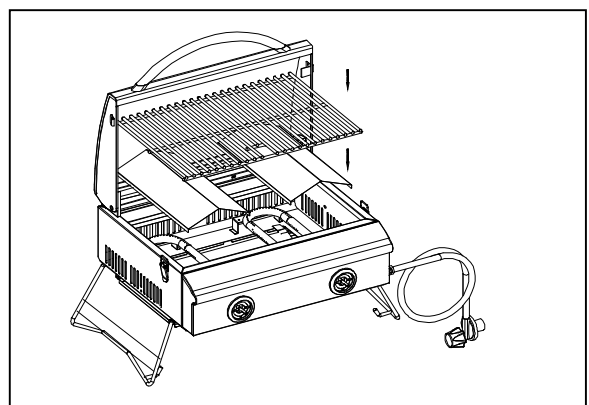

ASSEMBLY INSTRUCTIONS

5. Place on the control knobs as shown in fig. 4. Push and turn the knob and check for sparks.

Fig. 4

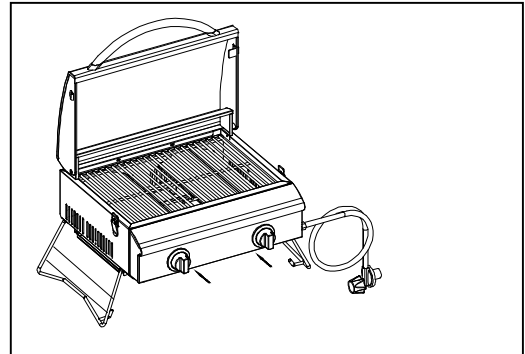

6. Attach the regulator with 1m hose to the gas cylinder by turning the regulator handle clockwise as shown in Fig. 5. If the outdoor cooking appliance is not in use, the gas must be turned "OFF" at the Liquid gas cylinder.

Fig. 5

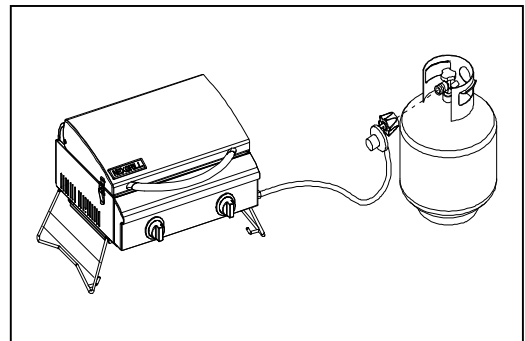

Check all gas supply fittings for leaks before each use. Do not use the grill until all connections have been checked and do not leak (see "Leak Testing" instructions on page 5).

Fig. 6

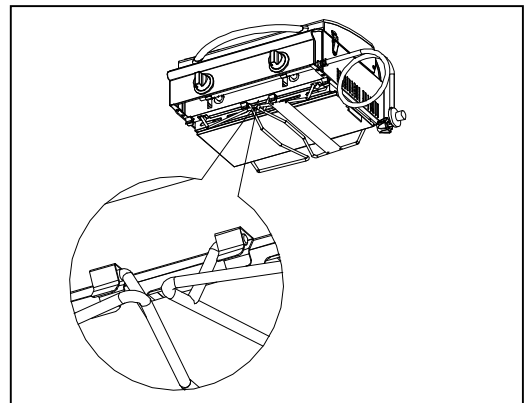

Note: When you are not using the grill, you can fold the legs and lock them in brackets as shown in Fig.6.

INSTALLATION INSTRUCTIONS

GAS HOOK-UP

Only the pressure regulator and hose assembly supplied with the grill should be used. Any replacement pressure regulator and hose assembly must be specified by the grill manufacturer. Do not use a Natural Gas supply.

Total gas consumption (per hour) with all burners set on "HIGH":

Main burners	5.9 KW
Total	5.9 KW

LIQUID GAS CYLINDER REQUIREMENTS

A dented or rusty gas cylinder may be hazardous and should be checked by your supplier. Never use a cylinder with a damaged valve.

Storage of an outdoor cooking gas appliance indoor is permissible only if the cylinder is disconnected and removed from the outdoor cooking gas appliance. The cylinder system must be arranged for vapor withdrawal. The cylinder must include a collar to protect the cylinder valve.

Remove the plastic valve cover from the Liquid gas cylinder. Make sure the grill gas hoses do not contact the grease pan or grill firebox when the Liquid gas cylinder is placed into the cart.

CONNECTING THE LIQUID GAS CYLINDER

To connect the Liquid gas supply cylinder:

The cylinder valve should be in the "OFF" position. If not, turn the valve clockwise until it stops.

Make sure the burner valves are in the "OFF" position.

Inspect the valve connections, port and regulator assembly. Remove debris and inspect the hose for damage.

When connecting the regulator assembly to the valve, use your hand to tighten the nut clockwise until it stops.

Use of a wrench could damage the quick coupling nut and result in a hazardous situation

Open the cylinder valve fully by turning the valve counterclockwise.

Before lighting the grill, use a soap and water solution to check all the connections for leaks.

If a leak is found, turn the cylinder valve "OFF" and do not use the grill until a local Liquid Gas dealer can make repairs.



WARNING

Never attempt to use damaged or obstructed equipment. See your local Liquid Gas dealer for repair.

INSTALLATION INSTRUCTIONS

DISCONNECTING THE LIQUID GAS CYLINDER

Turn the grill burner valves "OFF" and make sure the grill is cool.

Turn the Liquid gas cylinder valve "OFF" by turning clockwise until it stops.

Detach the regulator assembly from the cylinder valve by turning the quick coupling nut counterclockwise.

Place dust cap on cylinder valve outlet whenever the cylinder is not in use. Only install the type of dust cap on the cylinder valve outlet that is provided with the cylinder valve. Other types of caps or plugs may result in leakage of gas.

LEAK TESTING

GENERAL

Although gas connections on the grill are leak tested prior to shipment, a complete leak test must be performed at the installation site. Before each use, check all gas connections for leaks using the procedures listed below.

If the smell of gas is detected at any time, you should immediately check the entire system for leaks.

BEFORE TESTING

Make sure all packing materials have been removed from the grill, including the burner tie-down straps.



WARNING

Check all gas supply fittings for leaks before each use. Do not use the grill until all connections have been checked and do not leak. Do not smoke while leak testing. Never leak test with an open flame.

Make a solution of one part liquid detergent and one part water. You will need a spray bottle, brush, or rag to apply the solution to the fittings. For the initial leak test, make sure the Liquid gas cylinder is full.

TO TEST

1. Turn the burner valves off.
2. Turn the Liquid Gas cylinder valve counterclockwise to open the valve.
3. Apply the soap solution to all gas fittings. Soap bubbles will appear where a leak is present.
4. If a leak is present, immediately turn the gas supply "OFF" and tighten leaky fittings.
5. Turn the gas back "ON" and recheck.
6. Should the gas continue to leak from any of the fittings, turn the gas supply "OFF" and contact customer service at [United Kingdom 02392 322880](tel:02392322880).
7. If there is evidence of excessive abrasion or wear, or the hose is cut, it must be replaced prior to the outdoor cooking gas appliance being put into operation.

Only those parts recommended by the manufacturer should be used on the grill. Substitutions will void the warranty.



WARNING

Do not store grill indoors unless the cylinder is disconnected. Do not store cylinder in a building, garage, or any other enclosed area, and keep area, and keep out of reach of children at all times.

INSTALLER FINAL CHECK

Maintain specified clearance of 0.6m from combustible materials and construction.

- ▮ All internal packaging has been removed.
- ▮ The hose and regulator are properly connected to the Liquid Gas cylinder.
- ▮ The unit has been tested and is free of leaks.
- ▮ The gas supply shutoff valve has been located.
- ▮ All burners are installed.
- ▮ Keep the instruction manual for future reference



WARNING

1. Do not store spare Liquid gas cylinders under or near this appliance.
2. Never fill the cylinder beyond 80 percent capacity.
3. If the information in item 1&2 is not followed exactly, a fire causing death or serious injury may occur.

OPERATION INSTRUCTIONS

Fig.8

LIGHTING THE GRILL

1. Place the legs in up position.
2. Make sure the gas cylinder is tightly treaded into the regulator (hand tighten only).
3. Open lid. Always open lid when lighting.
4. Push and turn Main burner knob slowly to IGNITE/HIGH as show in Fig.8, burner should light immediately.
5. If ignition does not occur in 3-5 seconds, turn the control knob "OFF."

Wait 5 minutes before attempting to re-light the grill. If the grill fails to ignite after the second attempt, call customer service at [United Kingdom 02392 322880](tel:02392322880) for assistance. With burner lit, gently close the lid and allow the grill to warm up for 20-30 minutes prior to use.

Note: If the knob can't spark insert the match into the lighting rod as show in Fig.9. Ignite the match and insert though the cooking grids to the burner.

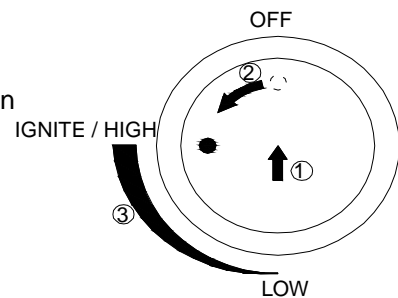
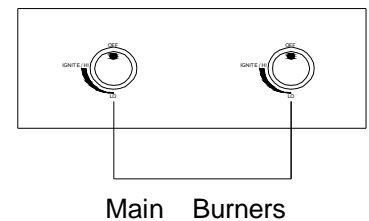
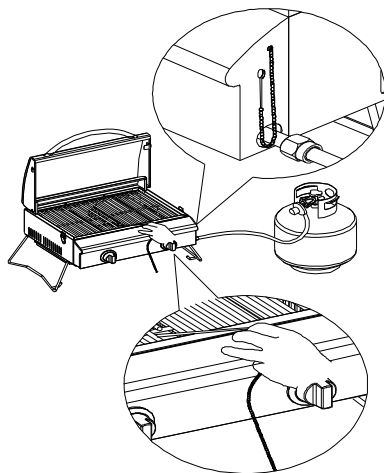

Fig.9



1. Push
2. Turn knob to Ignite/High
3. Adjust flame

TURNING THE GRILL OFF

1. Turn knob to "OFF" position.
 2. Turn the gas cylinder control knob to the "OFF" position.
- Caution:** Do not attempt to re-light the grill without following all the lighting instructions.
3. Allow the grill body to cool at least 30 minutes before attempting to move or transport.

OPERATION INSTRUCTIONS

FLAME CHARACTERISTICS

Check for proper burner flame characteristics. Burner flames should be blue and stable with no yellow tips, excessive noise, or lifting as shown in Fig. 10. The following steps should be followed for correcting the flame characteristics:

Turn the control knobs and Liquid gas cylinder valves "OFF."

Allow the grill and burners to cool.

If the flame is yellow (not enough air), turn the adjustment screw found at the front of the burner counterclockwise.

If the flame is noisy or lifts away from the burner (too much air), turn the adjustment screw clockwise.

If these adjustments do not correct the problem, contact customer service at [United Kingdom 02392 322880](tel:02392322880).

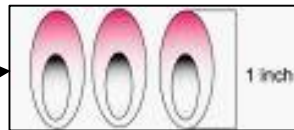

Visually check the burner flames prior to each use, the flames should look like this picture. If they do not, refer to the burner maintenance part of this manual.

Fig. 10

USING THE GRILL

1. Find a level surface to grill on.
2. Allow the grill to warm up with the lid closed for 5 minutes prior to cooking.
3. You may cook on the grill in any weather. If the temperature is extremely cold or hot, the cooking times will be slightly increased or decreased. Keep the grill out of excessive winds when operating.
4. The cooking times listed below are only suggestions. Cooking times vary depending on thickness of meats and the desired degree of preparation.

GRILLING

- Steak – (T-Bone), thick cut, medium doneness: grill 10 minutes on each side on MED setting.
- Chicken – (Quarters), average size fryer: grill 30 minutes per side on MED setting. Check for doneness.
- Pork – (Ribs/chops): grill 10-20 minutes per side on MED setting. Check for doneness.
- Fish – grill 20-30 minutes on LOW setting.
- Turkey - (Breast): grill 10 minutes per pound or until internal temperature reaches 170°F (77°C) on MED setting.

CARE AND MAINTENANCE

There is very little care and maintenance needed. The Table Top Grill is designed and made of materials that will last many years with normal use. Following these instructions will improve the longevity of the grill and quality of cooking. To ensure safe operation of your grill, the area of cooking should always be kept free of combustible materials of any type, such as gasoline or other flammable vapours or liquids.

Outside Grill Parts - This is stainless steel. It can be cleaned easily with warm soapy water or any stainless steel cleaner.

Cooking Grid and Grease Tray – The cooking grid is made of stainless steel. The cooking grid should be brushed with a steel brush immediately after cooking, while the grill is still warm. The grease tray is also stainless steel and can be cleaned with a flat scraper such as a putty knife.

Caution: The grease tray must be kept clean and free of heavy buildup for the grill to perform properly and to eliminate flare-ups.

CARE AND MAINTENANCE

Grill Main Burners - Extreme care should be taken when removing a burner. It must be correctly centered on the orifice before any attempt is made to relight the grill. Frequency of cleaning will depend on how often you use the grill.

Failure to properly place the burner over the orifice could cause a fire to occur behind and beneath the valve panel, thereby damaging the grill and making it unsafe to operate.

Before cleaning, make sure the gas supply and control knobs are in the "OFF" position and the burners have cooled.

To remove the main burners for cleaning:

1. Locate the burner screw at the rear of the firebox.
2. Remove the screw and lift the burner out of the firebox.

To clean the grill burners:

1. Clean the exterior of the burner with a wire brush. Use a metal scraper for stubborn stains or debris.
2. Clear clogged ports with a straightened paper clip. Never use a wooden toothpick as it may break off and clog the port.
3. Check and clean burners / venturi tubes for insects and insect nests. A clogged tube can lead to a fire beneath, and behind the main control panel.

To reinstall the main burners:

1. Insert the burner over the main burner gas valve (part# 6 on Page 15).
2. Make sure the orifice spud (A) is inside the burner venturi (B) as shown in Fig. 11.
3. Align the burner screw hole with the firebox hole, insert screw and tighten.

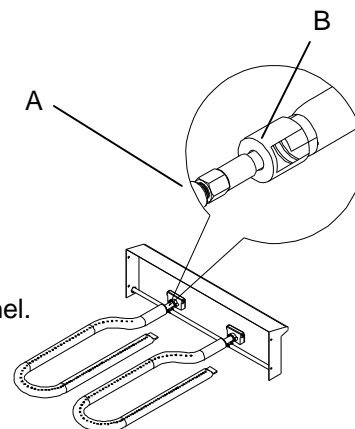

Fig.11

Firebox - Use warm soapy water to clean this area. Do not allow grease to build up.

Drain Hole – The drain hole must be kept clear of grease and food particles to allow drippings to drain properly into the grease tray. This must be done to maintain proper operation of your grill.

General - This grill, like all equipment, will look better and last longer if kept out of the weather when not in use.

Caution: Do not store gas cylinders in enclosed areas. When using a cover or moving the grill, always wait until the grill has cooled for at least 30 minutes.

- Not obstructing the flow of combustion and ventilation air.
- A clogged tube can lead to a fire beneath the appliance.

This unit must be kept in an area free from combustible materials, gasoline and other flammable vapours and liquids.

Make sure all openings into the grill body are free of blockages or debris and there are no objects or materials blocking the flow of combustion or ventilation. Make sure the legs are in the up position when using the grill.

Check burner air inlet openings (behind the inlet guard on the right end of the grill body) for insect nests or blockages. Make sure the slots in the burner tube are clear.

When the grill is not in use, turn the control knob to the "OFF" position and remove the gas cylinder from the regulator. Remove the regulator from the burner.

For outdoor use only, if stored indoors, detach gas cylinder and store outdoors. Gas cylinders must be stored out of reach of children.

Important

First-time use: It is important that the grill be lit and allowed to heat up for at least 30 minutes before any food is placed on the cooking grid. It is normal for some smoke to appear during the initial operation of the grill. After initial heating, the grill is ready for use. A cooking spray can be used on the cooking grids to allow easier clean up.

CARE AND MAINTENANCE

THIS COOKING APPLIANCE IS FOR OUTDOOR USE ONLY AND SHALL NOT BE USED IN A BUILDING, GARAGE OR ANY OTHER ENCLOSED AREA.

MOVING INSTRUCTIONS

Caution: Never move the grill with burner lit.

Make sure control knob is in the "OFF" position. Disconnect the gas cylinder from the regulator. Remove the regulator from the grill. Be sure the grill has completely cooled for at least 30 minutes. Close the lid and secure the latch. Place the legs in the down position. Use the handle to carry the grill.

Note: It is best to leave the grease tray in place attached to the bottom of the grill; some grease may continue to drip from drain hole during transport.

TROUBLE SHOOTING

 **WARNING** Spiders and insects can nest inside the burners of the grill and disrupt gas flow. This very dangerous condition could cause a fire behind the valve panel, thereby damaging the grill and making it unsafe for operation. Inspect the grill at least twice a year.

When to Look for Spiders

You should inspect the burners at least twice a year or immediately after any of the following conditions occur:

1. The smell of gas in conjunction with burner flames appearing yellow.
2. The grill does not reach temperature.
3. The grill heats unevenly.
4. The burners make popping noises.

BEFORE CALLING FOR SERVICE

Problems	What To Do
Grill will not light.	<ul style="list-style-type: none">•Check to see if the liquid gas cylinder is empty.•Check burner ports for any blockage. Use a soft wire brush to clear plugged ports.•Check the gas orifice on the burner for an obstruction. If orifice is blocked, clean with a needle or thin wire. NEVER USE A WOODEN TOOTHPICK.
Burner flame is yellow or orange in conjunction with gas odour.	<ul style="list-style-type: none">•Check for spiders and insects.•Call customer service at United Kingdom 02392 322880.
Low heat with the control knob on the "HIGH" setting.	<ul style="list-style-type: none">•Make sure the grill area is clear of dust.•Make sure the burner and orifice are clean.•Check for spiders and insects.•Is there adequate gas supply available?•Is the grill being preheated for 15 minutes?

If the grill does not function properly, use the following checklist before contacting your dealer for service.

REPLACEMENT PARTS LIST

For replacement parts, call our customer service department at [United Kingdom 02392 322880](tel:02392322880).

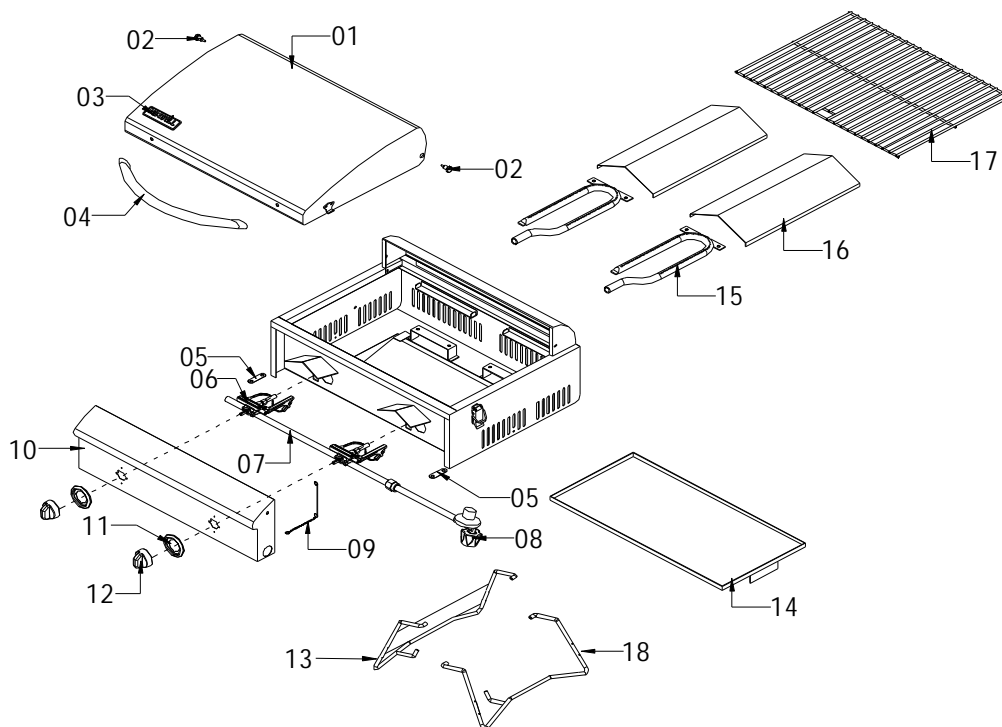

Part	Description	Part #	Part	Description	Part #
1	Main lid	1 pc	10	Main control panel	1 pc
2	Main lid screw	2 pcs	11	Control knob bezel	2 pcs
3	Logo	1 pc	12	Control knob	2 pcs
4	Main lid handle assembly	1 pc	13	Foldable leg, left	1 pc
5	Control panel connector	2 pcs	14	Grease tray	1 pc
6	Gas valve	2 pcs	15	Main burner (question mark)	2 pcs
7	Main manifold	1 pc	16	Flame tamer	2 pcs
8	Regulator, LP	1 pc	17	Cooking grid	1pc
9	Lighting rod	1 pc	18	Foldable Leg, right	1pc

Limited Warranty (Model # 820-0015)

The manufacturer warrants to the original consumer-purchaser only that this product (Model #820-0015) shall be free from defects in workmanship and materials after correct assembly and under normal and reasonable home use for the periods indicated below beginning on the date of purchase. The manufacturer reserves the right to require photographic evidence of damage, or that defective parts be returned, postage and or freight pre-paid by the consumer, for review and examination.

- **MAIN BURNERS:** 3 year *LIMITED* warranty against perforation.
- **FLAME TAMERS:** 2 year *LIMITED* warranty against perforation.
- **COOKING GRIDS:** 3 Year *LIMITED* warranty; *does not cover dropping, chipping, scratching, or surface damage.*
- **STAINLESS STEEL PARTS:** 3 Year *LIMITED* warranty against perforation; *does not cover cosmetic issues like surface corrosion, scratches and rust.*
- **ALL OTHER PARTS:** 1 Year *LIMITED* warranty (Includes, but not limited to, valves, frame, housing, cart, control panel, igniter, regulator, hoses) **Does not cover chipping, scratching, cracking surface corrosion, scratches or rust.*

Upon consumer supplying proof of purchase as provided herein, Manufacturer will repair or replace the parts which are proven defective during the applicable warranty period. Parts required to complete such repair or replacement shall be free of charge to you except for shipping costs, as long as the purchaser is within the warranty period from the original date of purchase. The original consumer-purchaser will be responsible for all shipping charges of parts replaced under the terms of this limited warranty. This limited warranty is applicable in the Europe only, is only available to the original owner of the product and is *not transferable*. Manufacturer requires reasonable proof of your date of purchase. Therefore, you should retain your sales receipt and/or invoice. If the unit was received as a gift, please ask the gift-giver to send in the receipt on your behalf, to the below address. Defective or missing parts subject to this limited warranty will not be replaced without registration or proof of purchase. This limited warranty applies to the functionality of the product **ONLY** and does not cover cosmetic issues such as scratches, dents, corruptions or discolouring by heat, abrasive and chemical cleaners or any tools used in the assembly or installation of the appliance, surface rust, or the discolouration of stainless steel surfaces. Surface rust, corrosion, or powder paint chipping on metal parts that does not affect the structural integrity of the product is not considered a defect in workmanship or material and is not covered by this warranty. This limited warranty will not reimburse you for the cost of any inconvenience, food, personal injury or property damage. If an original replacement part is not available, a comparable replacement part will be sent. You will be responsible for all shipping charges of parts replaced under the terms of this limited warranty.

ITEMS MANUFACTURER WILL NOT PAY FOR:

- Service calls to your home.
- Repairs when your product is used for other than normal, single-family household or residential use.
- Damage resulting from accident, alteration, misuse, lack of maintenance/cleaning, abuse, fire, flood, acts of God, improper installation, and installation not in accordance with electrical or plumbing codes or use of products not approved by the manufacturer.
- Any food loss due to product failures.
- Replacement parts or repair labour costs for units operated outside Europe.
- Pickup and delivery of your product.
- Postage fees or photo processing fees for photos sent in as documentation.
- Repairs to parts or systems resulting from unauthorized modifications made to the product.
- The removal and/or reinstallation of your product.
- Shipping cost, standard or expedited, for warranty/non warranty and replacement parts.

DISCLAIMER OF IMPLIED WARRANTIES; LIMITATION OF REMEDIES

Repair or replacement of defective parts is your exclusive remedy under the terms of this limited warranty. Manufacturer will not be responsible for any consequential or incidental damages arising from the breach of either this limited warranty or any applicable implied warranty, or for failure or damage resulting from acts of God, improper care and maintenance, grease fire, accident, alteration, replacement of parts by anyone other than Manufacturer, misuse, transportation, commercial use, abuse, hostile environments (inclement weather, acts of nature, animal tampering), improper installation or installation not in accordance with local codes or printed manufacturer instructions.

THIS LIMITED WARRANTY IS THE SOLE EXPRESS WARRANTY GIVEN BY THE MANUFACTURER. NO PRODUCT PERFORMANCE SPECIFICATION OR DESCRIPTION WHEREVER APPEARING IS WARRANTED BY MANUFACTURER EXCEPT TO THE EXTENT SET FORTH IN THIS LIMITED WARRANTY. ANY IMPLIED WARRANTY PROTECTION ARISING UNDER THE LAWS OF ANY STATE, INCLUDING IMPLIED WARRANTY OF MERCHANTABILITY OR FITNESS FOR A PARTICULAR PURPOSE OR USE, IS HEREBY LIMITED IN DURATION TO THE DURATION OF THIS LIMITED WARRANTY.

Neither dealers nor the retail establishment selling this product has any authority to make any additional warranties or to promise remedies in addition to or inconsistent with those stated above. Manufacturer's maximum liability, in any event, shall not exceed the documented purchase price of the product paid by the original consumer. This warranty only applies to units purchased from an authorized retailer and or re-seller. NOTE: Some states do not allow an exclusion or limitation of incidental or consequential damages, so some of the above limitations or exclusions may not apply to you; this limited warranty gives you specific legal rights as set for herein.

If you wish to obtain performance of any obligation under this limited warranty, you should write to:

Nexgrill Customer Relations

5270 Edison Avenue, Chino, CA91710

All consumer returns, parts orders, general questions, and troubleshooting assistance can be acquired by calling **United Kingdom 02392 322880.**