



# Infection Prevention Breakthrough Program

Supporting Healthier Communities Since 1973



# Welcome to MCL

MCL is a global leader in infection prevention, offering customized solutions, expert training programs and cutting edge products. MCL's equipment and technology will ensure your workplace, home and facilities are clean, sustainable and healthy.

There are a lot of aspects of life that have changed since COVID-19 entered our world. Learn how we support healthier communities with the products and services we provide for your best cleaning practices.

**03** **Advanced Technology**

**04** **Face Masks**

**06** **Vaccination Product Solutions**

**08** **Electrostatic Sprayers & Foggers**

**09** **Professional & Service Robots**

**10** **Antibacterial Bathroom Solutions**

**12** **Disinfection and Protective Equipment**

**13** **Client Reviews**

# Advanced Technology



## Thermal Guard

Touchless temperature screening system solution to protect your environment from risk of illness and viruses through the use of advanced thermal imaging technology.

> **\$4,200.00 each or \$75.60 / month**

Thermal Guard LED 40" Stand

> **\$1,050.00 each or \$18.90 / month**

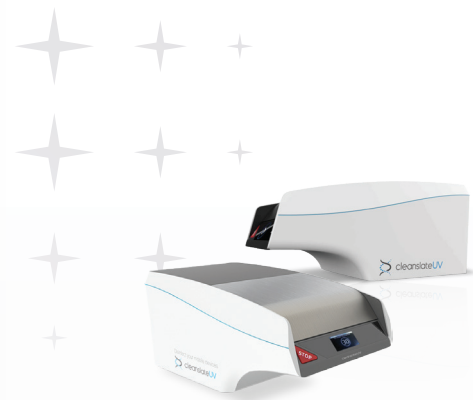

## Cleanslate UV

CleanSlate UV technology uses rapid 360° sanitization proven to kill at least 99.999% of dangerous bacteria and viruses.

> **\$7,950.00 each  
or \$143.10 / month**



## Lucid Drone

D1 Disinfecting Drone offers effective and efficient sanitation application methods. The drone offers 360 degree obstacle avoidance while having a downward facing sensor to maintain consistent altitude.

> **\$56,000.00 each  
or \$4,999.99/month**



## Pathogen Solutions

Pathogen Solutions is a footwear sanitizing solution that uses Ozone+ UVC Shoe Disinfection Technology. It is 110x more effective at eliminating pathogens than UVC Light.

> **\$27,500.00 each  
or \$495.00 / month**

# The world's first ever Face Masks for the masses

**Quick, reliable, safe and economical face masks  
for your employees, guests & patrons**

- 5 ear slots to fit all ages – universal fit for kids and adults alike
- Made in Germany and patented worldwide
- Compact design allows for high volume capacity
- Secured dispenser delivers one mask per patron
- Comfortable, breathable and form fitting
- Tested to the same effectiveness as a 3-ply pavillion face mask
- Requires no manual management
- Quick and easy dispenser installation on any wall or surface

> **Stand for Dispensers for the Anti Transfer Masks: \$145.00 each**

**Anti Transfer Masks - 1000/Roll: \$130.00 each**

**10+ Rolls: \$119.00 each**

**50+ Rolls: \$105.00 each**

**100+ Rolls: \$90.00 each**



**Wall  
mounted  
or  
free standing  
options  
available**

**Dispenser installation  
available**

- ✓ **Water Repellent**
- ✓ **50 GSM**
- ✓ **PP Fleece**
- ✓ **>90% filtration rate**

**BREATHE**

# NanoMasks

Introducing NanoMask. The most comfortable, easiest breathing, easiest sealing, high-efficiency mask available today. Breathing Is Believing.

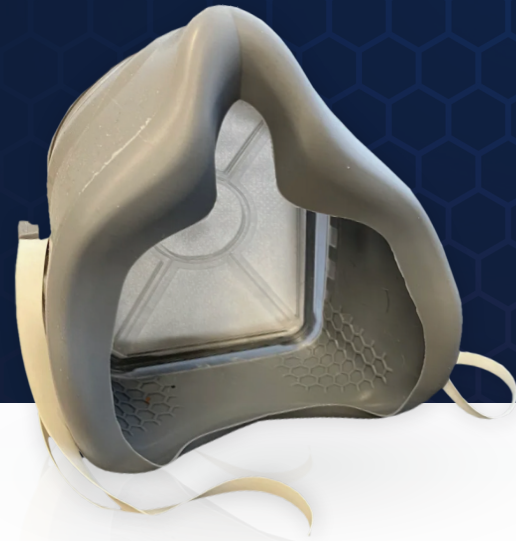

The BREATHE mask by Invotek Medical is the most comfortable, easy-breathing, and rugged lightweight reusable mask available today.

BREATHE comes complete with reusable combo earloop headstrap for high-intensity activity as well as lightweight ear loops for leisure activity. BREATHE masks come complete with 3 revolutionary easy-breathing high-efficiency NanoMask filters from Prescientx.

Available in Standard, 95, 100, and Sport versions



**NanoMask**

## Lightweight Elastomeric Masks

- Breathes like it's not even there
- Forms to your face and seals without effort
- Stays cool and comfortable all day
- Doesn't fog up glasses or goggles
- Designed for daily use up to 30 days

Sold in packages of 10

> **\$79.00 each**



**NanoMask**

## Reusable Mask Filters

- Very, very easy breathing
- Min 90% eff
- Change weekly

Sold in packages of 10

> **\$20.00 each**

# Vaccination

## Product Solutions

### Haier Biomedical DW-86L100J Personal - 86°C ULT Freezer

- Suitable for clinical, medical, scientific research, quarantine and other departments to store items under low temperature conditions
- Applicable for universities, hospitals, disease prevention and control centres, blood stations, scientific research institutes, electronics and chemical enterprise laboratories and biomedical engineering research institutes
- For storage of biological products and sample biological samples such as red and white blood cells, viruses, bone and bacteria
- Also used for electronic devices and other materials used for cryogenic tests

> **\$7,600.00 each or \$136.80 / month**



### Wealy Disposable Safety Syringe

- Single use safety with one-handed operation
- Simple operation like standard syringes without extra steps
- Automatic needle retraction after medication fully discharged
- Non-exposed needle after automatic retraction
- Completely evacuating medication and low dead space
- Low dead space ensuring patient recovery
- Saving medical charges for patients

> **\$0.49 each**



### Kontrol BioCloud® Air Quality Analyzer

- BioCloud is a real-time analyzer designed to detect airborne viruses. It has been designed to operate as a safe space technology by sampling the air quality continuously
- With a proprietary detection chamber that can be replaced as needed, viruses are detected, and an alert system is created in the Cloud or over local intranet
- BioCloud's applications include classrooms, retirement homes, hospitals, mass transportation and others

> **\$15,000.00 each or \$269.99 / month**



### Becton-Dickenson Sharps Containers

- For protection and proper disposal of items such as used syringes, scalpels and blades
- Features include: strong and durable polypropylene construction; point first disposal; one way tamper-resistant entry; secure cap closure; protective recessed flanges to protect against tampering, touch contamination and needle "bounce back"
- Can be incinerated or autoclaved
- No assembly required
- Recommended for first aid rooms, medical and dental offices and clinical laboratories

> **\$6.00 each**



## Abatement Technologies PRED750 Portable Air Scrubber

- 200-750 cfm, Variable Speed Airflow
- Powerful - Max 7,500 ft<sup>3</sup> @ 6 ACH
- Portable and Incredibly Lightweight (35lbs w filters)
- User-Friendly Controls and Secure Stacking
- Durable, Polyethylene Cabinet Made From UL94HB Flame Retardant Resin



> **\$1,243.00 each or \$22.37 / month**

## Abatement Technologies HEPA-AIRE® PAS2400 Portable Air Scrubber

- 200-750 cfm, Variable Speed Airflow
- Powerful - Max 7,500 ft<sup>3</sup> @ 6 ACH
- Portable and Incredibly Lightweight (35 pounds w filters)
- User-Friendly Controls and Secure Stacking
- Durable, Polyethylene Cabinet Made From UL94HB Flame Retardant Resin



> **\$5,023.00 each or \$90.41 / month**

## Hongray Powder Free Nitrile Examination Gloves

- Material: Nitrile
- Color: Violet
- Length: 9"
- Palm Thickness: 2.5 MIL
- Health Canada MDALL License
- ASTM D6319 - Medical Application
- ASTM D6978 - 35 Chemo Drugs
- ISO9001, ISO 13485, MDSAP



> **\$20.42 each**    **100+:** \$19.45 each    **1500+:** \$17.64 each  
**750+:** \$18.52 each    **3500+:** \$16.80 each

## Abatement Technologies PRED1200 Portable Air Scrubber

- Powerful airflow - rated up to 900 CFM
- Provides 6 ACH @ max 9,000 ft<sup>3</sup>
- True HEPA filtration - 99.97% efficiency @ 0.3 microns or higher
- Low Power Consumption - Use less than 3.5 amps @ 120VAC
- Flexible Operation - Can operate in the upright or horizontal position



> **\$2,312.00 each or \$41.62 / month**

## Genano® 5250M/5250 Air Decontamination Unit

- Superior cleaning capacity for spaces with high contamination risk
- Suited for cleanrooms, such as laboratories or isolation rooms
- The air decontamination unit is also created for R&D production areas, where ultra-pure air is required
- Cleaning capacity: Max. 500 m<sup>3</sup>/h
- Particle size arrestance: > 0,003 µm
- Cleaning efficiency: 99.5 %
- Gas removal: Included 800 g activated carbon, 60 mm
- Dimensions (W x H x D) 600 x 1680 x 600 mm



> **Starting at \$11,800.00 each or \$212.40 / month**

## L2 Gowns

- Back: Open Back Tie
- Colour: Blue
- Composition/Ingredients
  - Non-Woven Fabric
  - Knitted Cuff & Elastic Cuff
- Master Carton: 230 pcs
- Disposable: Yes
- Fluid Resistant: Yes
- Item Type Latex: Latex-Free
- Size: 115x137 cm ± 3cm
- Weight: 40gsm
- (60% PP + 40% PE)
- Certification: CE & FDA



> **\$1.15 each**

## EMist EPIX360 Electrostatic Disinfectant Portable Backpack and Roller Cart

- 360° comprehensive coverage
- Uses 75% less chemicals
- 54,000 sq. ft. per hour coverage time
- Reduces labor time by 45%
- Saves 50% on the cost of solutions
- Average room disinfected in less than three minutes

> **\$5,200.00 or \$93.60 /month**  
**10+:** **\$4,500.00 each**



# Electro Static Sprayers & Foggers

## Victory Cordless Electrostatic Handheld Sprayer

- Weighs only 5.9 lbs. with a full tank
- Cordless convenience allows for effortless movement room to room
- 3-in-1 nozzle lets you set the spray particle size to match your application
- Easy Fill HDPE 33.8oz refillable tank allows you coat up to 2800 sq. ft. on 40 micron setting
- Victory 16.8V Lithium-Ion battery allows you to run between 20-80 tanks on a single charge

> **\$1,062.00 each or \$19.11 /month**  
**10+:** **\$886.30 each or \$15.95 /month**



## Victory Cordless Electrostatic Backpack Sprayer

- Removable Easy Fill HDPE tank holds 2.25 gallons of chemical, allowing you to coat up to 23,000 sq. ft.
- Cordless convenience allows for effortless movement room to room
- 3-in-1 nozzle allows you to set particle size to match your application
- 4ft hose with quick release valve allows for comfortable reach and maximum maneuverability

> **\$2,290.79 each or \$41.23 /month**  
**10+:** **\$1,949.10 each or \$35.08 /month**



## EMist EPIX360 Electrostatic Disinfectant Handheld Sprayer

- Powerful, durable, and provides breakthrough disinfectant application performance - more coverage, less waste & better results
- Simply fill the 8-ounce tank and the EPIX360 goes to work laying down an even, uniform and wraparound layer of germ-killing power up to 4,000 high-touch point sq. ft.

> **\$1,400.00 each or \$25.20 /month**  
**10+:** **\$1,220.00 each or \$21.96 /month**



## TVX - X1B Electrostatic Sprayer

- Includes 2 lithium-ion batteries & charger
- Electrically charged droplets of solution provide total and even coverage of a surface or object including hard to reach areas and wrap completely around the object

> **\$794.88 each or \$14.31 /month**  
**10+:** **\$670.00 each or \$12.06 /month**



## TVX - X5 Corded 5L Fogger

- The X5 is an "Ultra Low Volume (ULV) cold fogger". A lightweight, portable unit that allows the user to disinfect/sanitize open areas and spaces quickly
- Low pressure is applied to a high volume of air to push through a nozzle to create precisely sized tiny droplets, creating a fog/mist

> **\$744.12 each or \$13.39 /month**  
**10+:** **\$619.50 each or \$11.15 /month**



## EnviroNize® Bure ULV Fogger

- The EnviroNize® Bure ULV Fogger enables injection of anolyte and catholyte solutions to every corner inside or outside of any vehicle
- Enables spraying of dynamic materials including water-based and oil-based materials while functioning as a humidifier and microorganism sprayer

> **\$1,024.00 each or \$18.43 /month**  
**10+:** **\$955.00 each or \$17.19 /month**





# Professional & Service Robots

A series of intelligent transportation robots that operate in indoor environments such as restaurants, hotels, shopping malls, airports, banks, libraries, office buildings, hospitals, factories and other indoor environments.

## G1 Guiding Robot

- This commercial guiding robot is the best partner to guide an accurate way for every customer
- This guiding robot applies the best sensor technologies, LIDAR/SLAM/Infrared/Sonar sensors, to realize autonomous and accurate path planning and navigation, and the voice microphone interface can be used to communicate intelligently with the user
- It is capable of providing services such as guidance, shopping guide, information release, voice dialogue, and more

> \$23,250.00 each or \$418.50 / month



## T6 Delivery Robot

- This intelligent transport robot with machine vision and LIDAR achieves autonomous positioning navigation, intelligent obstacle avoidance and is capable of fully autonomous movement in indoor locations and intelligent interaction with humans
- The T6 Delivery Robot is capable of autonomous navigation through machine vision, laser radar, and LIDAR, and integrates touch switches and other 8 sensors to achieve intelligent obstacle avoidance

> \$16,530.00 each or \$297.54 / month



## M2 Disinfection Robot

- The robot has the function of intelligent autonomous recharge, through which the robot can independently find, match, and contact the charging port to realize automatic re-charging
- Autonomous positioning is achieved through machine vision and laser radar. Intelligent obstacle avoidance function is realized through the integrated application of different sensors such as contact sensors
- The basic disinfection process is as follows: First, the user selects the disinfection mode. Second, the user selects the route to the destination or moving point. Next, the robot will go to each destination one by one after departure

> \$63,000.00 each or \$1,134.00 / month



# Antibacterial Bathroom Solutions

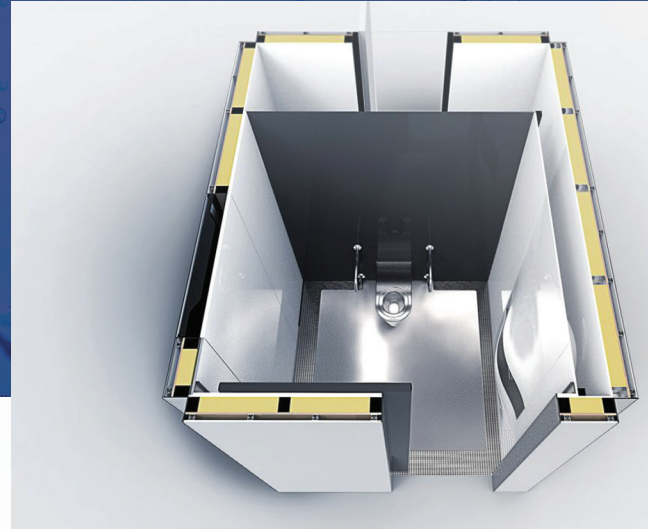

## NIU Smart Toilet

The new mobile antibacterial bathroom. NIU has brought together the best engineers to create a complete line of bathroom fixtures to meet your requirements.

NIU's line offers waterless toilets, conventional toilets and intelligent toilets equipped with a self-cleaning system. Different options are available depending on the model.

> Starting at \$12,500.00 each or \$225.00 / month



## Aereus™ BioFree Copper Coated Toilet Seat

Fast-acting self-sanitizing surfaces through use of copper. Introducing a toilet seat made with CuVerro Shield™ by Aereus Technologies that continuously kills bacteria.

This product contains a high impact polyurethane toilet seat and mounting hardware coated with CuVerro Shield™ that kills 99.9% of bacteria.

> \$475.00 each



## SmartFLO<sub>3</sub> Ozonated Water Sink

The world's first self-disinfecting sink. The SmartFLO<sub>3</sub> sink uses ozonated water to eliminate bacteria both on hands and on the sink itself. Ozonated water has been shown to be more effective than soap and water for bacterial removal from hands.

SmartFLO<sub>3</sub> also provides a source of ozonated water for general cleaning and sanitizing. Convenient and twice as powerful as bleach.

> Starting at \$3,750.00 each or \$67.50 / month



## Comac Commercial Hand Dryer

The first cavity dryer that is 99.9% bacteria free. simple design, drainage system, eco-friendly, maximum ergonomoy and a lifetime warranty. **Simply a no brainer.**

> Starting at \$999.00 each  
or \$17.98 per month

- Lifetime Warranty
- Made in Canada
- ECO Friendly
- 99.9% Bacteria Free
- Dry Hands in 7 Seconds
- Adjustable Temperature

## Features

- THIN design with rapid drying, cost effective and most hygienic
- Uses a highly efficient motor to create strong winds to sweep the water off from hands
- Dry hands in 7 seconds by super-powered jet air
- 3-point infrared sensor
- Brushless powerful motor and HEPA filter to create clean air without bacteria
- Brightness unique LED indicator
- 25 seconds of continuous timer protection
- Clean air by UV sterilization to keep air bacteria free
- No disposal, storage or labor costs compared with paper towels. You only need to clean once a day
- Up to 90% savings, compared to paper towel costs
- Intelligent heat element, active only when ambient temperature is less than 25 °C
- ECO-friendly product by power-saving clean technology
- Integrated water evacuation drain to water tank and/or main bathroom drain

## Dimensions

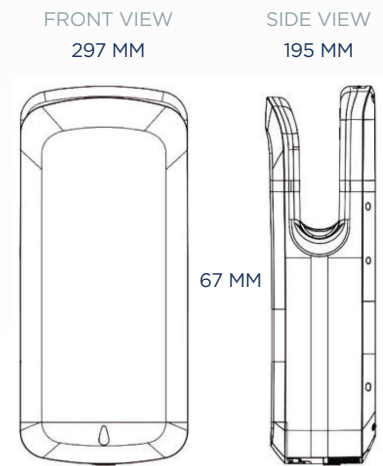

## Applications

- Washrooms and clean up areas, commercial facilities, factories, restaurants, hospitals, schools, pools and gyms
- Ideal for high and very high traffic public areas
- Made for high traffic public areas

## Awards and Certifications



## Look at who is using Comac Hand Dryers:



# Disinfection & Protective Equipment

## VirusKiller™ VK401 Air Purifier & Air Steriliser

The perfect air purifier and steriliser for medium to large rooms. Combining pre-filter, HEPA filter, activated carbon and the reactor cell of 8 super UVC lamps with 40 TiO2 hexagon filters makes it the ultimate solution for spaces up to 60 square meters. The perfect air steriliser for medical surgeries, dental surgeries, childcare facilities, leisure facilities, government buildings, single patient rooms, the VK 401 is best for:



- Smaller commercial spaces and for your home
- The perfect air steriliser for medium to large rooms

> **\$3,625.00 each or \$65.25 / month**

## Sanuvox ASEPT.2X Twin Tower Mobile UV

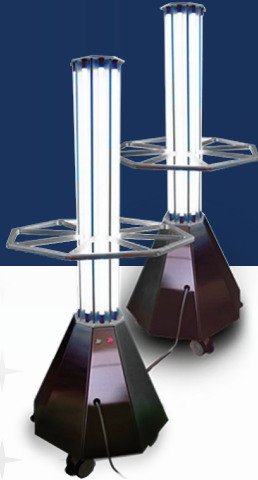

The world's fastest Mobile UVC System utilizes two high-power units designed to disinfect an entire patient room or O.R. in as little as 5 minutes.

> **Starting at \$35,000.00 each or \$630.00 / month**

Commissioning & training needed for all installations

## ThermalPass Portable 100 Series Temperature Detection System

ThermalPass Temperature Detection System identifies potential risk carriers by using multiple thermal sensors to detect elevated body temperatures accurately, efficiently, and discretely.

- 24 thermal sensors in each device scanning 1,200 temperatures per minute
- Capacity of up to 60 people per minute
- Non-contact temperature measurement

- Accuracy of  $\pm 0.4^{\circ}\text{C}$
- Dual zone temperature system
- Configurable audible and visual alerts
- Does not encroach on privacy
- Real-time analytics and enterprise integration
- Accommodates wheelchairs, strollers and groups of 2 (parent & child)

> **\$9,300.00 each or \$167.40 / month**

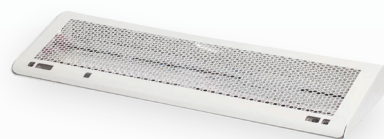
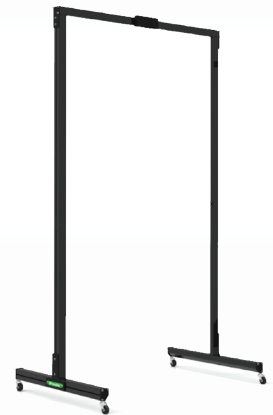

## Sanuvox ASEPT.1X MAX AutoUV

Take surface disinfection and patient protection to the next level by automatically disinfecting bathrooms, equipment rooms, and utility rooms 5-20 times per day, autonomously; for just pennies a day.

Magnetic door contacts and dual passive infrared occupancy sensors ensure safe operation. Wireless programming and communication built-in.

> **\$4,750.00 each or \$85.50 / month**

Commissioning & training needed for all installations

## Protect Your Office Desk Dividers

The use of transparent physical barriers has been recommended by the Public Health Agency of Canada, the US CDC, and the World Health Organization. Designed with criteria and input from the Global Health Crisis Coordination Center (GHC3), a non profit founded by the Center of Disease and Control, and Microsoft.

- No tools required
- Cost effective and sets up in seconds
- Custom sizes available
- Ships flat and economically

> **\$65.00 each**





**Dear Mr. Jacobs:**

Thanks very much for your kind words about my involvement in the recent COVID-19 Respond & Recover Virtual Conference + Expo. I was pleased to take part in such an important livestream event.

COVID-19 has posed enormous challenges for people and governments around the world. Here in Ontario, my colleagues in the Ontario government and I are doing everything in our power to confront this deadly virus. The health, safety and well-being of the people of Ontario is our top priority. By all of us working together, we can and will overcome this pandemic. I wish you all the best.

- Doug Ford, Premier of Ontario

# Meeting the needs of the Ontario Government

## Client Reviews

**Thanks Team MCL!**

Your generous donations to Habitat for Humanity have helped hundreds of families in our community. We are proud to partner with you in your tireless mission to support healthier communities.



We could not have achieved our goals in terms of cleanliness and health without the continued guidance and support of the MCL Team. Our students are working proficiently in an engaging and motivating space thanks to the leading Infection Prevention Programs implemented by MCL.

- David Lanys, President  
College of Sports Media

MCL is at another level of innovation. The support their team has provided in terms of robotics and software strategies continues to elevate Sunnybrook, achieving a leadership status in the Canadian health care system.

- Lou Fernandes, Director of Environmental Services  
Sunnybrook Hospital

Thank you Team MCL! Based on the results of our work together, we developed an environmental sustainability program and action plan that promotes the use of environmentally sound management practices.

- Julian Tersigni C.Tech, LEED  
Facility Manager, Building ScienceGreen Associate  
Earthrangers Centre For Sustainable Technologies





**Office**

905.761.9995

**Toll Free**

800.430.9555 x 123

**Email**

info@mclgreen.com

101 Jacob Keffer Pkwy.  
Concord, ON L4K 5N8



[mclgreen.ca](http://mclgreen.ca)