

SECONDARY CONNECTOR KIT

KD503



Caution!

- Only personnel qualifying to work with high voltage equipment and circuits are allowed to do the installation.
- Make sure the circuits are disconnected from the voltage supply and correctly grounded. Never connect or disconnect live circuits. Voltage is lethal.
- Follow the local instructions for safety precautions or refer to the FAA advisory circular AC150/5340-26 (maintenance of Airport visual Aid Facilities). Follow also Advisory circular AC150/5370-10 part XI Lighting installations. Always test the installation according to above mentioned documents and local instructions.
- Make sure that dimensions of the cable comply with the type of connector used. In case of any kind of non-compliance do not proceed with the installation.
- Check www.efla.net for possible updates of installation instructions.

Dimensional Data

Plug	Receptacle	Conductor Size	AWG	Cable Diameter
KD503	KD503/R	1.5-2.5 mm ²	16-14	2.8-4.0 mm
KD503.1	KD503R.1	4.0-6.0 mm ²	12-10/8	3.8-5.5 mm
KD503.2	KD503R.2	4.0-6.0 mm ²	12-10/8	2.8-4.0 mm
KD503.3	KD503R.3	4.0-6.0 mm ²	12-10/8	5.0-8.0 mm



Contents

- A. Silicone grease tube
- B. Body with connecting parts
- C. Plug or receptacle housing

The kit also includes: installation manual and paper towel

KD503-series

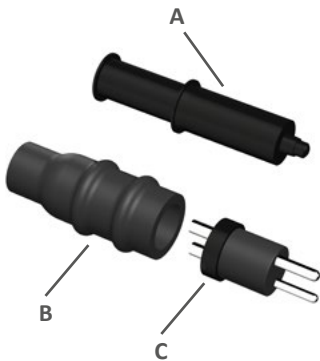

KD503R-series

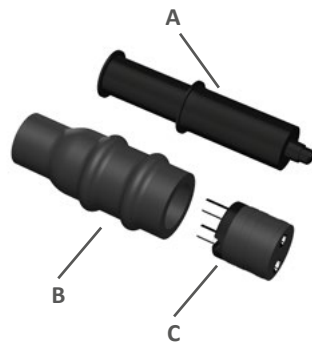

1. Clean approximately 20 cm of the cable end with a cleanser, i.e. spirit or equivalent and let dry.
2. It is recommended to remove sharp edge of the cable insulation especially when the cable diameter is in the upper half of the cable diameter range.
3. Open the front of silicon grease tube and dip the cable end in the silicone grease. Push the cable through the housing before the stripping of wires.
4. Clean the cable end again with cleanser, i.e. spirit or equivalent.



KD503-series

5. The insulation of wires should be stripped up to 8 ± 1 mm.



5

8 (mm)

KD503R-series

5. The insulation of wires should be stripped up to 8 ± 1 mm.



8 (mm)

6. Crimp the metal parts to conductors with a proper crimping tool and assure liable connection. Crimping tool suggestions for secondary connector kits:

- Conductor size 1.5 – 2.5 sqmm - Elpress DKB 0760
- Conductor size 4 – 6 sqmm – Elpress GWB 4099C
- Other trademarks may be used if the installer verifies adequate crimping.

***Caution:** Make sure that all cores are inside the pin and they do not cross each other.

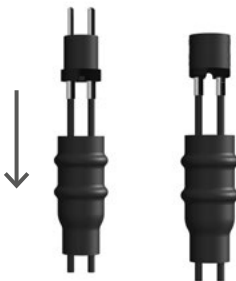

6



7. Grease the body with silicone grease tube. Note: the piston must be pushed to the end for maximizing the silicon grease volume inside of the housing. Pull the housing over the body and make sure that the housing is correctly in place. If the PMR 755 sealing unit is used with a receptacle, grease lightly the inner surface of the ring and push it over the housing.

KD503-series



KD503R-series



7



8

EFLA is the world's leading supplier of seamless power and communication products for airfield ground lighting circuits. With more than 30 years experience in the field, it develops, manufactures and sells globally-certified series isolation transformers, connector kits and prefabricated cable leads. The company's components meet the highest qualifications in materials and electrical design to withstand challenging installation in underground pits and cans and direct underground installation. Headquartered in Porvoo, Finland, EFLA supplies products to international airports around the world.