

PRODUCT DATASHEET

AGL Primary Connector Kits KDL1 & KDL10



FAA AC 5345-47, L-823 Styles 3 and 10, Class B

KDL1 for screened cable

KDL10 for unscreened cable



KDL1 & KDL10 are the most robust and fastest-to-install connector in the market, designed for a fast-and-easy watertight connection between the primary cable and the series isolating transformer. The connectors allow a rather fast mounting and assembly on site. KDL is fitted with unique cable gland, designed for industry experts requirements for easy and reliable use. Highest insulation resistance is provided by three insulation barriers. Screen continuity without crimping minimizes risk for leakages. KDL connector tolerates well bending and one connector fits to all cable diameters. KDL connectors are FAA certified.

- Superior isolation resistance by thermoplastic elastomer (TPE)
- Nominal rating: 25 A and 5000 V
- Cable diameter 9,0 - 21,0 mm (0.354 - 0.827 inches)
- Conductor size 6 - 13 mm² (8 - 6 AWG)
- ROHS compliance with EU directive NO2002/95/EC
- Fast to install 2 - 3 min
- Available for screened cables (KDL1) and unscreened cables (KDL10).

KDL primary connectors are packed and delivered in kits including all the necessary parts for making the assembly on primary cables. Each primary connector kit contains components for a pair (a plug and a receptacle).



Technical data

EFLA Type	Conductor Size (mm ²)	AWG	Cable Diameter (mm/inch)	Diameter at Wire Insulation (mm/inch)	Diameter & Length of Assembly (mm/inch)
KDL1	6	8**	9.0 – 17.0 mm 0.354 – 0.669"	7.5 – 13.0 mm 0.295 – 0.512"	42 mm, 276 mm 1.654", 10.886"
KDL1.6	10*	6	9.0 – 17.0 mm 0.354 – 0.669"	7.5 – 13.0 mm 0.295 – 0.512"	42 mm, 276 mm 1.654", 10.886"
KDL10	6	8**	8.0 – 12.0 mm 0.315 – 0.472"	7.0 – 13.0 mm 0.276 – 0.512"	34 mm, 268 mm 1.339", 10.551"
KDL10.1	6	8**	12.0 – 17.0 mm 0.472 – 0.669"	7.0 – 13.0 mm 0.276 – 0.512"	34 mm, 268 mm 1.339", 10.551"
KDL10.6	10*	6	9.0 – 17.0 mm 0.354 – 0.669"	7.0 – 13.0 mm 0.276 – 0.512"	34 mm, 268 mm 1.339", 10.551"

* 16mm² stranded, ** up to 19 strands

Outline dimensions

KDL1

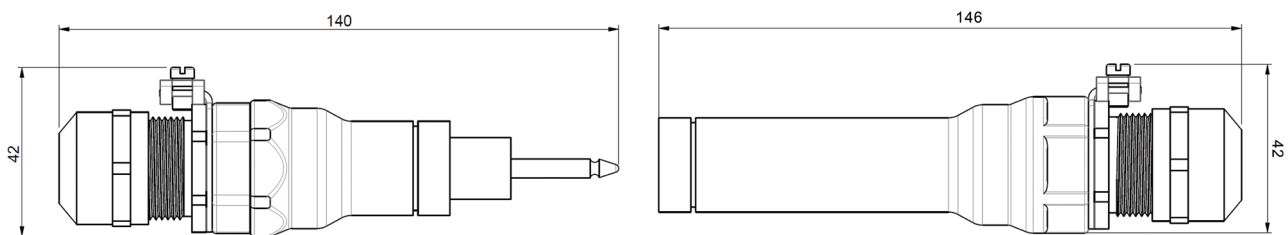

* KDL1 series weights 310 g/pc

KDL10

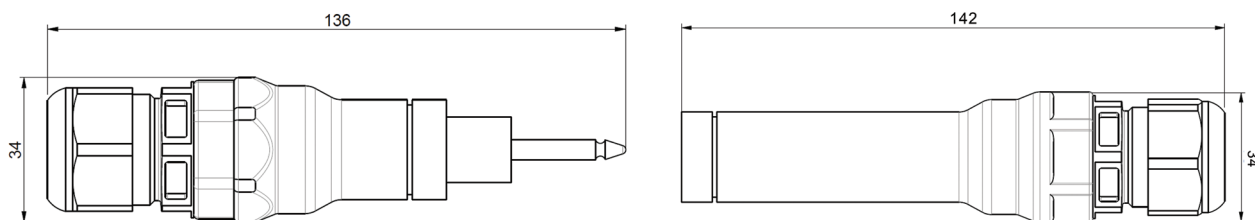

* KDL10 series weights 200 g/pc



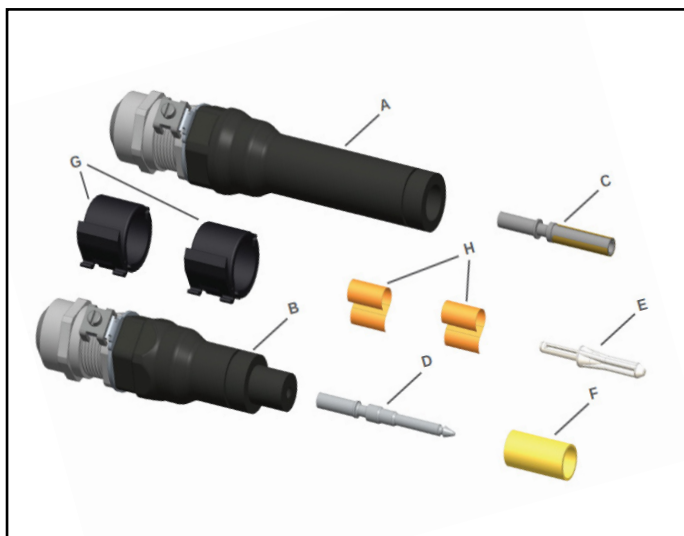

KDL1

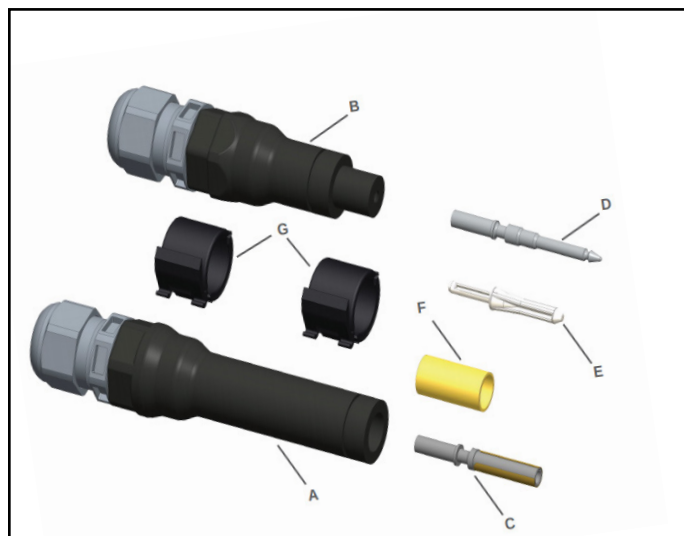

KDL10

Contents

- A. Receptacle housing
- B. Plug housing
- C. Socket
- D. Pin
- E. Guiding tool

- F. Measuring tool
- G. EFLA Lock
- H. Copper tape
- Not illustrated: Installation instructions, paper towel.

Suggested crimping tools

EFLA recommends these following tools:

Manual crimping tools:

- Elpress GWB 4099C
- KLAUKE K05/6
- KLAUKE K24
- KLAUKE K18

Electrical crimping tool:

- Elpress PVL 130S - WB4099



EFLA is the world's leading supplier of seamless power and communication products for airfield ground lighting circuits. With more than 30 years experience in the field, it develops, manufactures and sells globally-certified series isolation transformers, connector kits and prefabricated cable leads. The company's components meet the highest qualifications in materials and electrical design to withstand challenging installation in underground pits and cans and direct underground installation. Headquartered in Porvoo, Finland, EFLA supplies products to international airports around the world.