

Flip Top Tables | Nesting

Flip Top tables are available in three shapes, Rectangle, Expanse and Chevron, with Flip Top and flipping/nesting option. Standard fixed height is 29"; 25" and 27" heights available.

1-1/8" Particleboard Core with Flat Edge (F)

TOP is constructed of a 1-1/8" thickness 45# particleboard core with high-pressure laminate (HPL) top surface and phenolic backer sheet for balanced construction. 1-1/8" flat edge is secured to the bottom throughout the perimeter of the top to prevent the edge from pulling away. All tops have a 2.0" corner radius.

Nesting Leg Assembly

Nesting leg assembly is comprised of a pivoting cross-bar assembly and leg assembly. The cross-bar assembly allows tops to pivot for convenient storage. Cross-bar assembly includes a 1-1/2" square 14-gauge bar with injection molded bushings for smooth operation that is welded to 3/16" steel top mounting plates. Cross-bar assembly is powder coated black paint only. Leg assembly includes a vertical upright that is oval shaped extruded aluminum, approx. 1-7/8" x 3-3/4" with internal ribbing and a die-cast aluminum foot with a designed crown and flair to shape with internal ribbing. Foot includes 7/16" friction ring install for casters. Foot is secured to vertical upright using four (4) 1/4-20 x 1.5" bolts. Vertical upright is secured to the cross-bar assembly mounting plate using four (4) 1/4-20 x 1.5" bolts. Leg assemblies are secured to the top using eight (8) #12 x 3/4" wood screws. Foot and vertical uprights are powder coat paint. Mounting plate orientation and placement defined by pilot hole-pattern in top. Injection molded glass filled nylon latches are mounted independently and for safety require two-hand operation to release and pivot top.

Casters

75mm dual-wheel hard casters in black only. Grey caster can be added on (field installation). Caster is press-fit with 7/16" friction ring stem for installation. Casters are standard on all nesting tables.

Nesting Leg Tables | Storage

Depth of unit (except foot) when flipped up to the storage position is 8-1/4".

Compliance

- > Tested to applicable ANSI/BIFMA Furniture Standards
- > Indoor Advantage™ Gold. Indoor air quality certified to SCS-EC10.3-2014

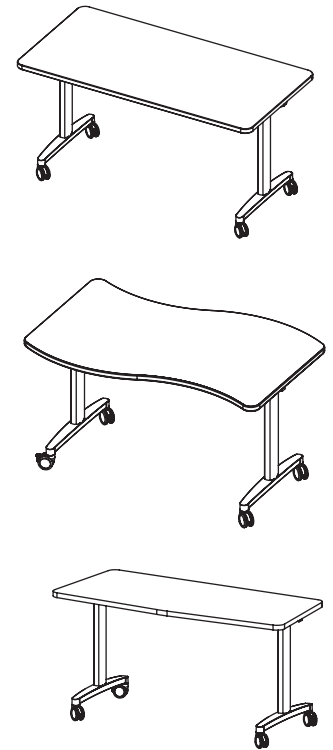

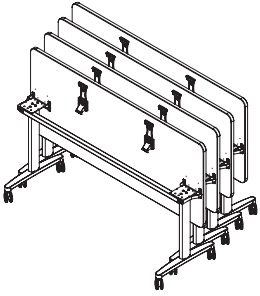

Flip Top Tables

Nesting Legs

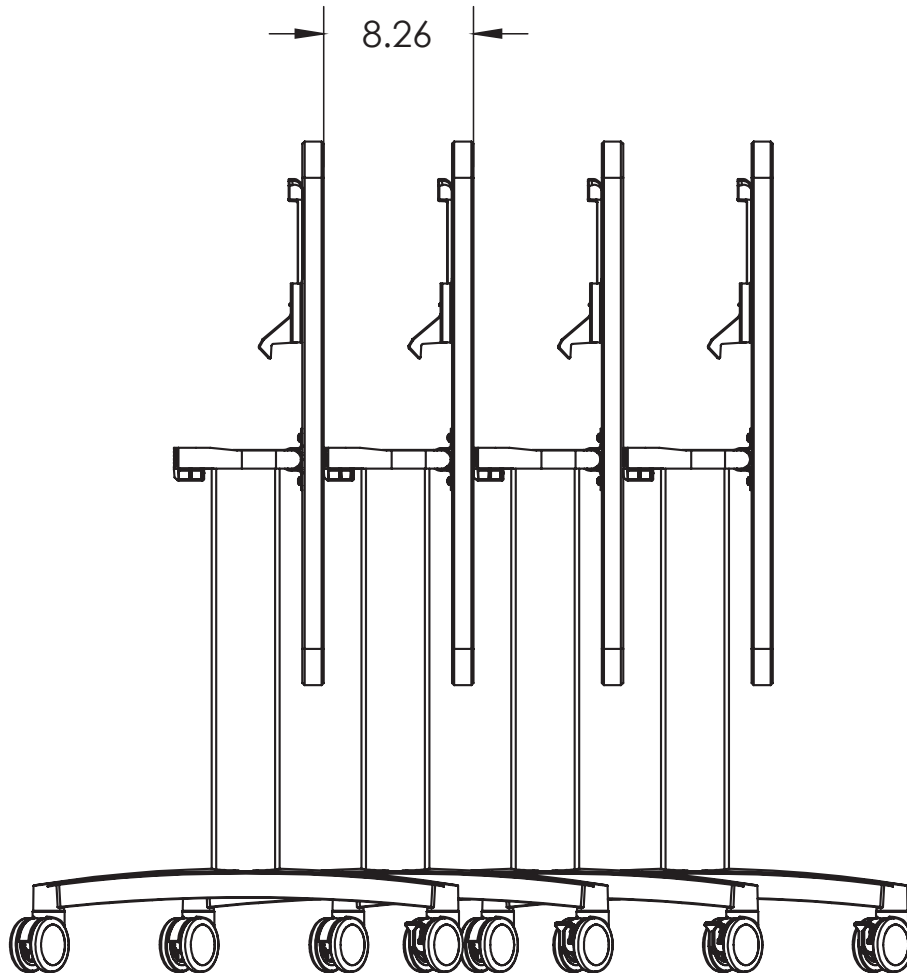

Formula for determining footprint of nested DTN tables: $D = S(N-1)+L$

D represents total distance (assuming casters at minimal distance)

S represents the spacing between units

N represents the number of units nested

L represents the length of the foot.

$$D = 8.26(4-1)+24$$

$$D = 48.78 \text{ inches (assuming casters at minimal distance).}$$

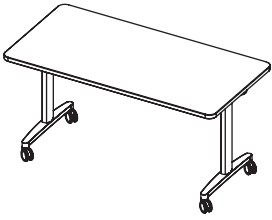

Flip Top Tables | Nesting Rectangle

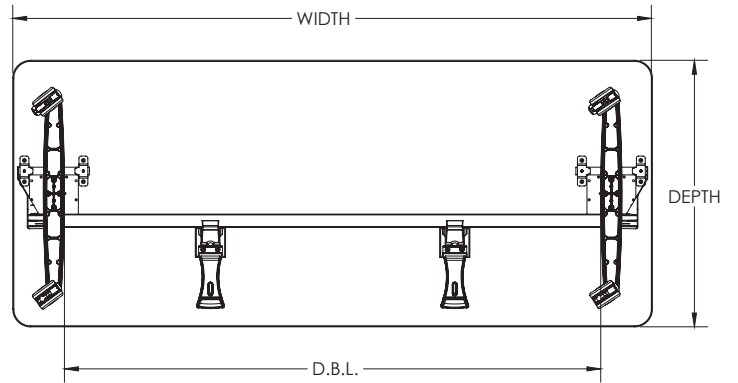
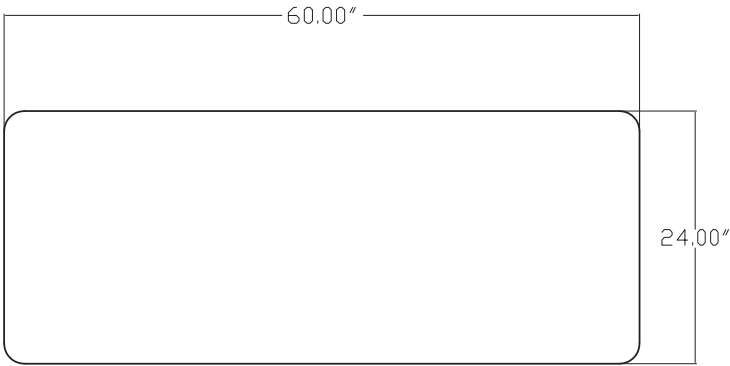

MODEL	DEPTH"	WIDTH"	HEIGHT"	D.B.L.
DTN-RC24F	24.0"	54.0"	29.0"	42.36"
DTN-RC25F	24.0"	60.0"	29.0"	48.36"
DTN-RC26F	24.0"	72.0"	29.0"	60.36"
DTN-RC34F	30.0"	54.0"	29.0"	42.36"
DTN-RC35F	30.0"	60.0"	29.0"	48.36"
DTN-RC36F	30.0"	72.0"	29.0"	60.36"
DTN7RC24F	24.0"	54.0"	27.0"	42.36"
DTN7RC25F	24.0"	60.0"	27.0"	48.36"
DTN7RC26F	24.0"	72.0"	27.0"	60.36"
DTN7RC34F	30.0"	54.0"	27.0"	42.36"
DTN7RC35F	30.0"	60.0"	27.0"	48.36"
DTN7RC36F	30.0"	72.0"	27.0"	60.36"
DTN5RC24F	24.0"	54.0"	25.0"	42.36"
DTN5RC25F	24.0"	60.0"	25.0"	48.36"
DTN5RC26F	24.0"	72.0"	25.0"	60.36"
DTN5RC34F	30.0"	54.0"	25.0"	42.36"
DTN5RC35F	30.0"	60.0"	25.0"	48.36"
DTN5RC36F	30.0"	72.0"	25.0"	60.36"

Notes

D.B.L. — distance between legs

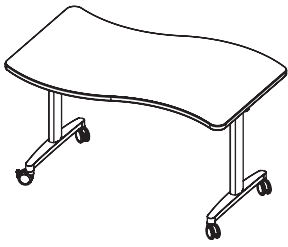

Flip Top Tables | Nesting Expanse

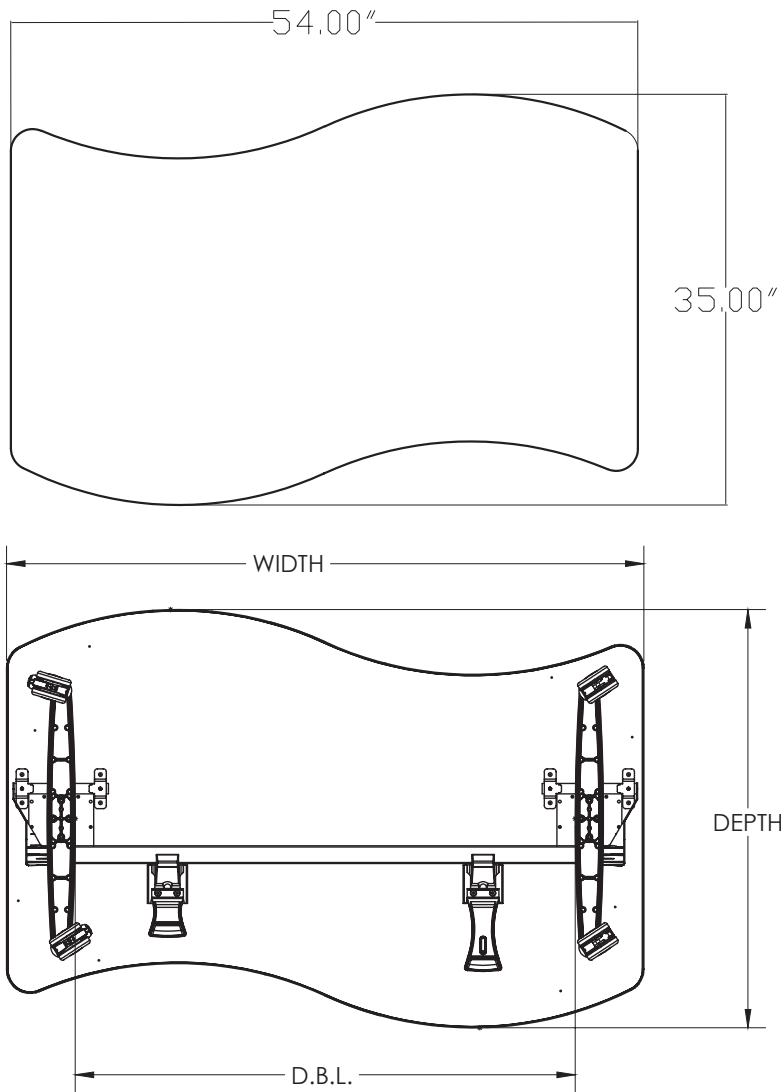

MODEL	DEPTH"	WIDTH"	HEIGHT"	D.B.L.
DTN-EX34F	30.0"	54.0"	29.0"	42.36"
DTN7EX34F	30.0"	54.0"	27.0"	42.36"
DTN5EX34F	30.0"	54.0"	25.0"	42.36"

Notes

D.B.L. — distance between legs

artcobell

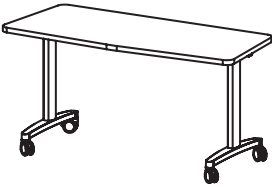

Flip Top Tables | Nesting Chevron

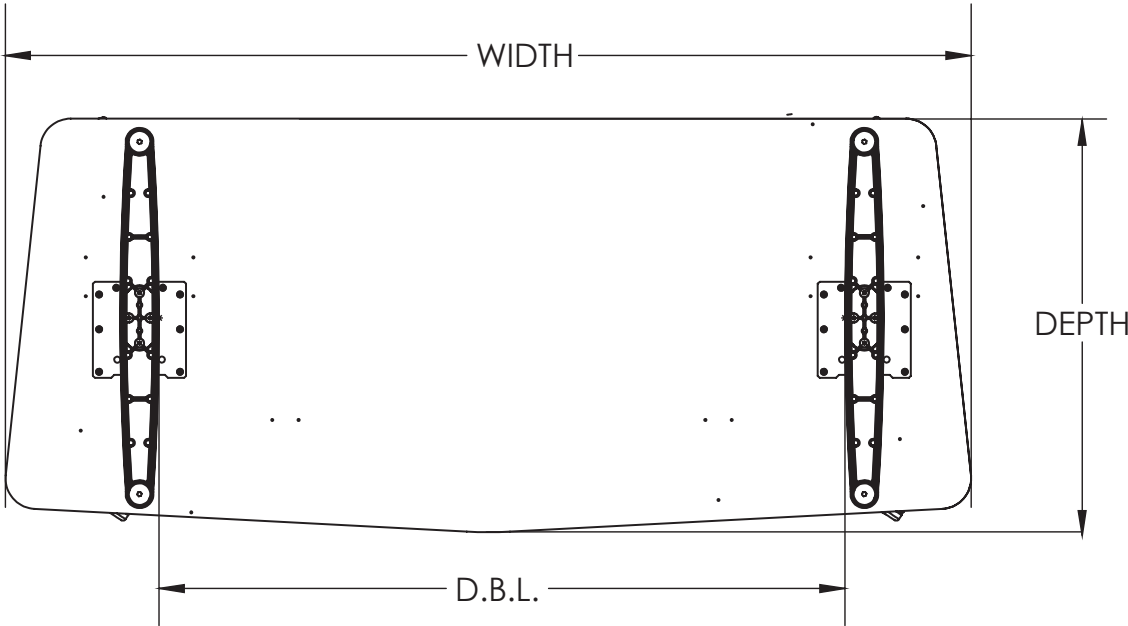
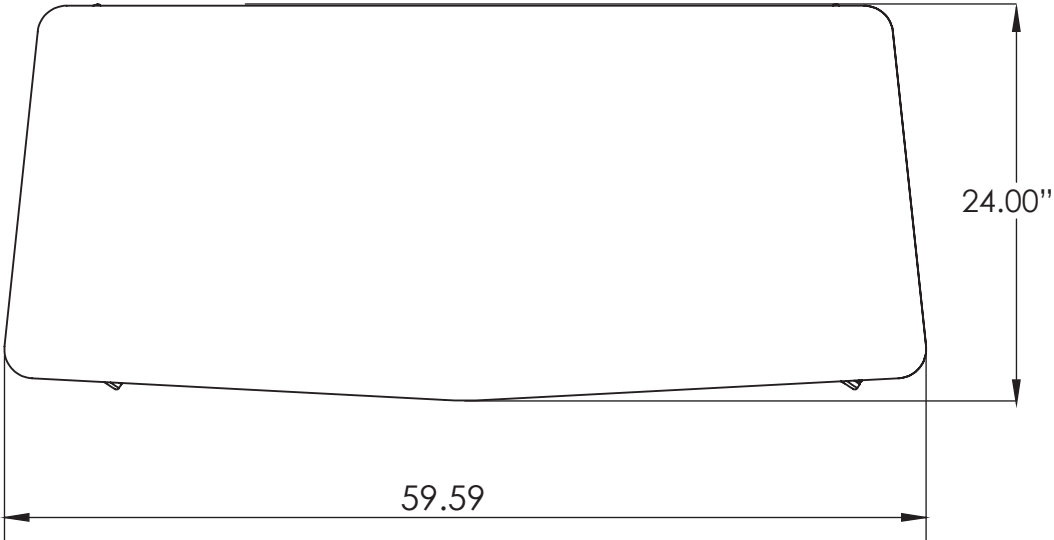

MODEL	DEPTH"	WIDTH"	HEIGHT"	D.B.L.
DTN-CV25F	24.0"	54.0"	29.0"	42.36"
DTN7CV25F	24.0"	54.0"	27.0"	42.36"
DTN5CV25F	24.0"	54.0"	25.0"	42.36"

Notes

D.B.L. — distance between legs