

# NXT MOV<sup>®</sup> Mobile

The NXT MOV Mobile Desk is an individual student work surface, cantilevered desk with integrated front casters for increased mobility. Available in both fixed top and flip top models in five fixed heights: 25", 27", 29", 36" and 42". Fully assembled with laminated work surface/top options.

## 3/4" Particleboard Core With Flat Banded Edge (E)

Work surface is constructed of 3/4" thick 45# particleboard core surfaced with high-pressure laminate (HPL) top and phenolic backer sheet for balanced construction. 3/4" flat vinyl edge is secured to the perimeter of the top.

## Frame

Frame is constructed of powder-coated steel: 1.5" diameter 14-gauge steel legs are welded to 2.5" diameter, laser-cut, 16-gauge steel column.

The fixed top mounting plate is 10-gauge steel held to the top with (8) #12-3/4 screws.

The flip-top mounting plate is formed 10-gauge steel welded to a 7/8 14-gauge pivot tube. Top is secured by two pivot brackets held on by 4 - #12-3/4 screws. Top latch is injection molded out of glass-filled nylon, rides in a 14ga steel formed track that is secured to the top by 4 - #12-3/4 screws.

## Glides/Casters

50mm front locking casters. Rear nylon glides are threaded for adjustability.

## Compliance

- > Indoor Advantage™ Gold. Indoor air quality certified to SCS-EC10.3-2014
- > Tested to applicable ANSI/BIFMA Furniture Standards

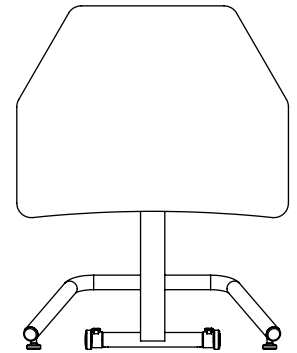
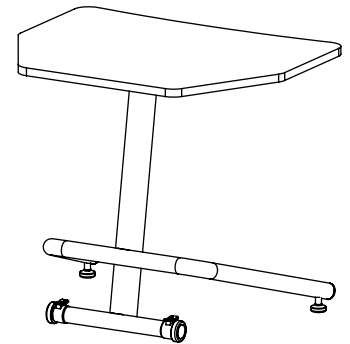

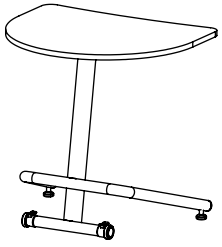

# NXT MOV Mobile

## Fixed Top | Half Moon

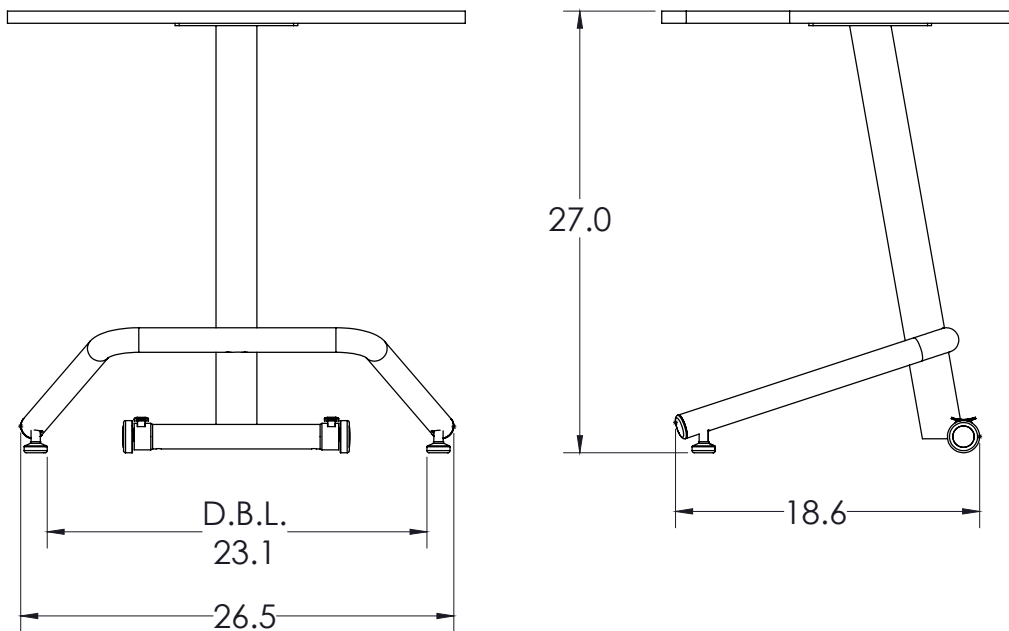
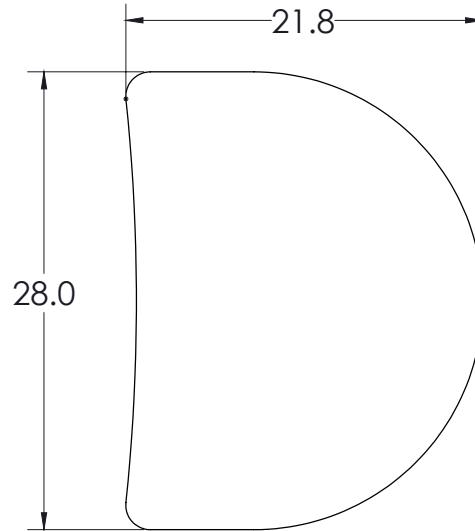

MODEL	FRAME WIDTH"	FRAME DEPTH"	TOP HEIGHT"	TOP WIDTH"	TOP DEPTH"
NS25-HME	26.5"	18.6"	25.0"	28.0"	21.8"
NS27-HME	26.5"	18.6"	27.0"	28.0"	21.8"
NS29-HME	26.5"	18.6"	29.0"	28.0"	21.8"
NS36-HME	26.5"	18.6"	36.0"	28.0"	21.8"
NS42-HME	26.5"	18.6"	42.0"	28.0"	21.8"

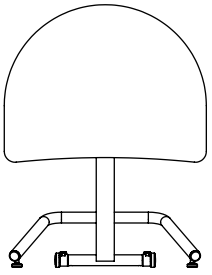

# NXT MOV Mobile

## Flip Top | Half Moon

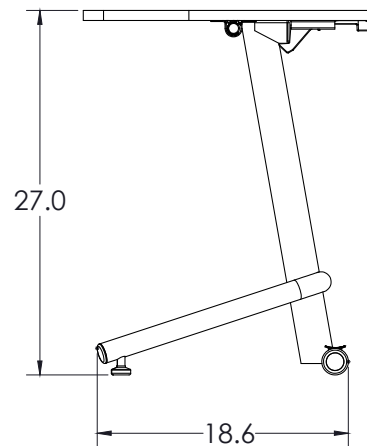
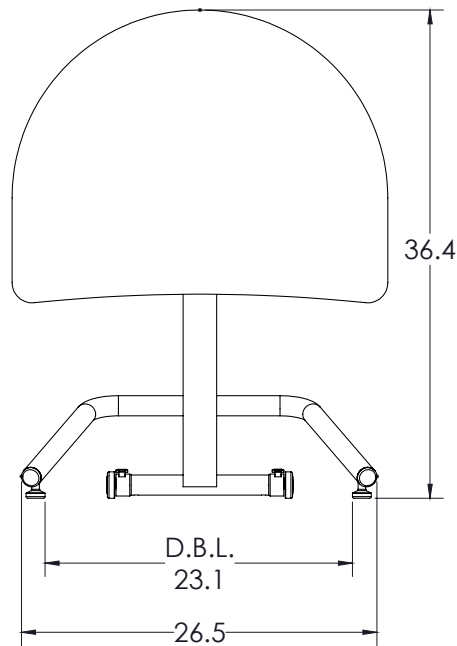
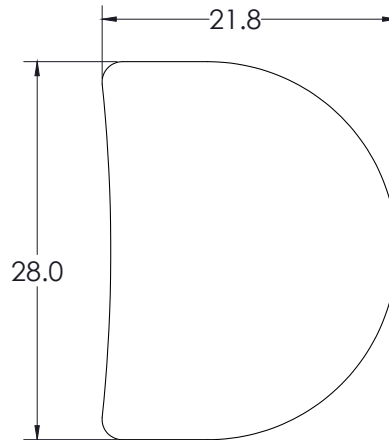

MODEL	FRAME WIDTH"	FRAME DEPTH"	TOP HEIGHT"	FLIPPED HEIGHT "	TOP WIDTH"	TOP DEPTH"
NF25-HME	26.5"	18.6"	25.0"	35.4	28.0"	21.8"
NF27-HME	26.5"	18.6"	27.0"	36.4	28.0"	21.8"
NF29-HME	26.5"	18.6"	29.0"	38.4	28.0"	21.8"
NF36-HME	26.5"	18.6"	36.0"	47.8	28.0"	21.8"
NF42-HME	26.5"	18.6"	42.0"	53.5	28.0"	21.8"

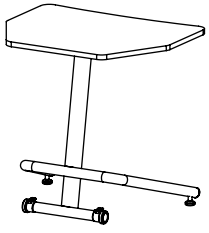

# NXT MOV Mobile

## Fixed Top | Home Plate

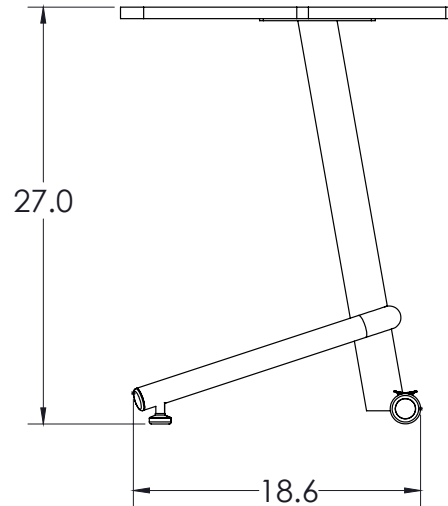
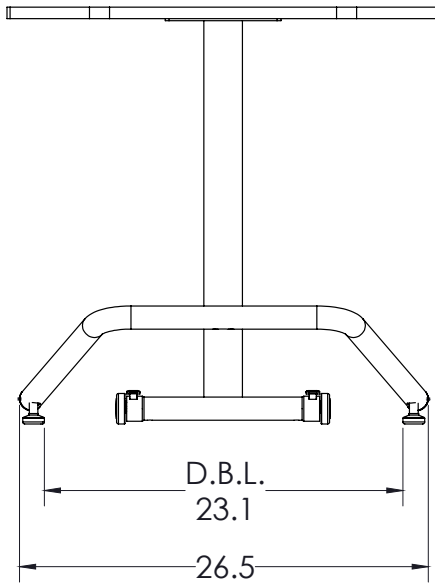
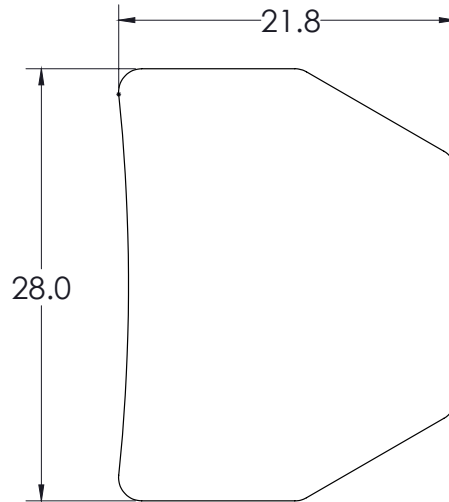

MODEL	FRAME WIDTH"	FRAME DEPTH"	TOP HEIGHT"	TOP WIDTH"	TOP DEPTH"
NS25-HPE	26.5"	18.6"	25.0"	28.0"	21.8"
NS27-HPE	26.5"	18.6"	27.0"	28.0"	21.8"
NS29-HPE	26.5"	18.6"	29.0"	28.0"	21.8"
NS36-HPE	26.5"	18.6"	36.0"	28.0"	21.8"
NS42-HPE	26.5"	18.6"	42.0"	28.0"	21.8"

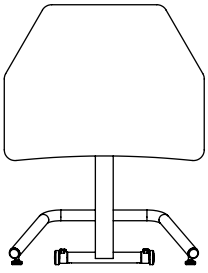

# NXT MOV Mobile

## Flip Top | Home Plate

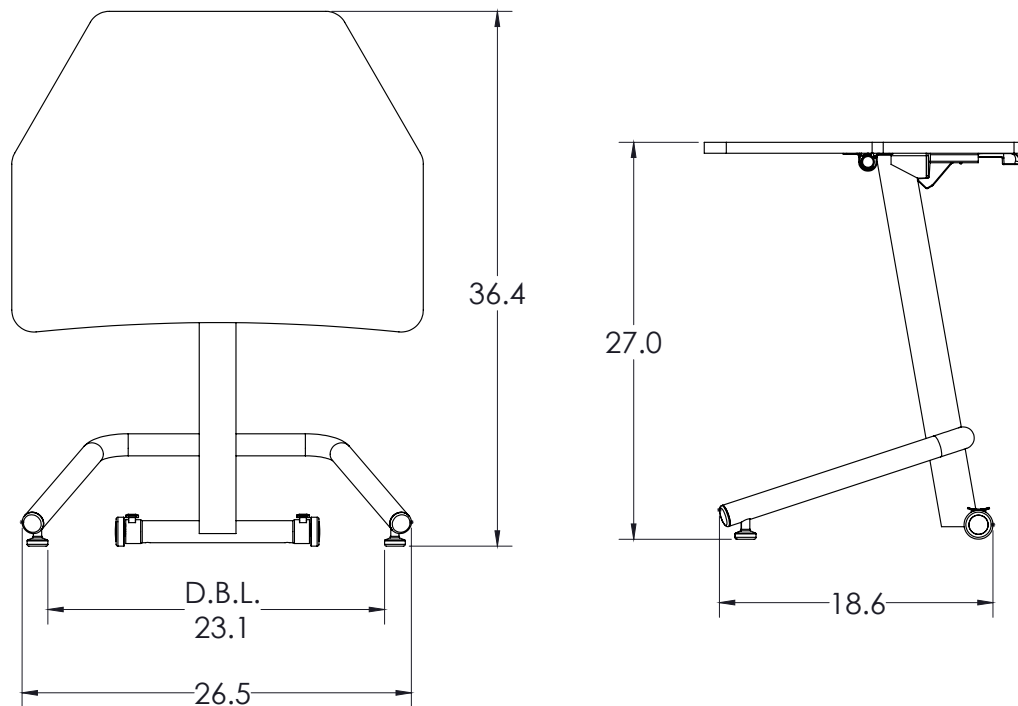
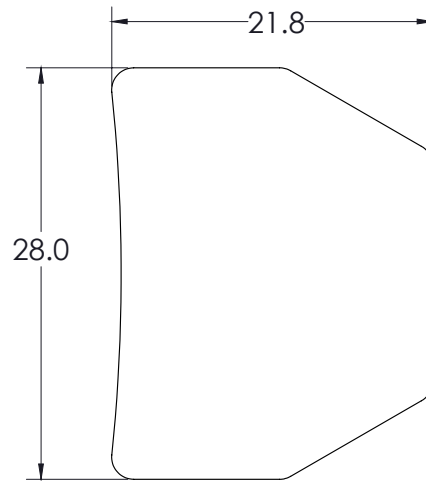

MODEL	FRAME WIDTH"	FRAME DEPTH"	TOP HEIGHT"	FLIPPED HEIGHT "	TOP WIDTH"
NF25-HPE	26.5"	18.6"	25.0"	35.4"	28.0"
NF27-HPE	26.5"	18.6"	27.0"	36.4"	28.0"
NF29-HPE	26.5"	18.6"	29.0"	38.4"	28.0"
NF36-HPE	26.5"	18.6"	36.0"	47.8"	28.0"
NF42-HPE	26.5"	18.6"	42.0"	53.5"	28.0"



# NXT MOV Mobile

## Fixed Top | Trapezoid

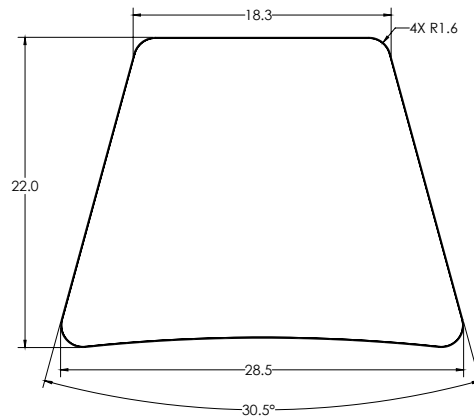
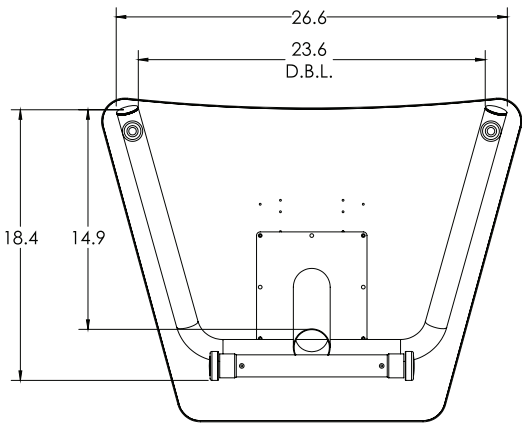
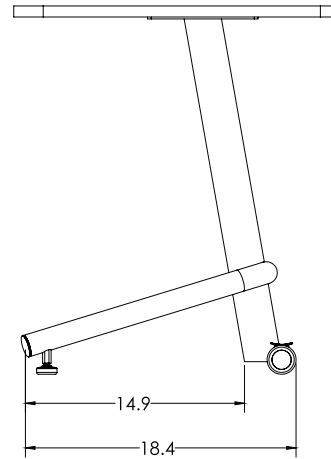
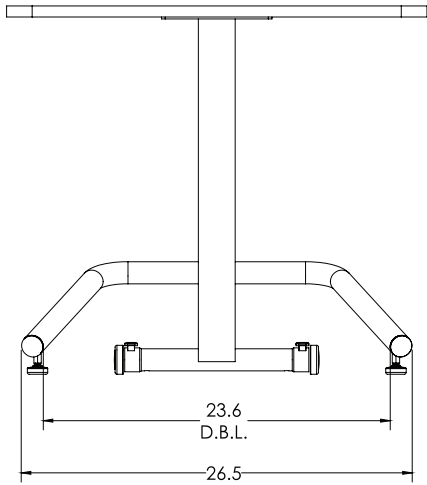

MODEL	FRAME WIDTH"	FRAME DEPTH"	TOP HEIGHT"	TOP WIDTH"	TOP DEPTH"
NS25-TZE	26.5"	18.6"	25.0"	28.5"	22.0"
NS27-TZE	26.5"	18.6"	27.0"	28.5"	22.0"
NS29-TZE	26.5"	18.6"	29.0"	28.5"	22.0"
NS36-TZE	26.5"	18.6"	36.0"	28.5"	22.0"
NS42-TZE	26.5"	18.6"	42.0"	28.5"	22.0"

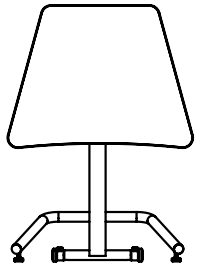

# NXT MOV Mobile

## Flip Top | Trapezoid

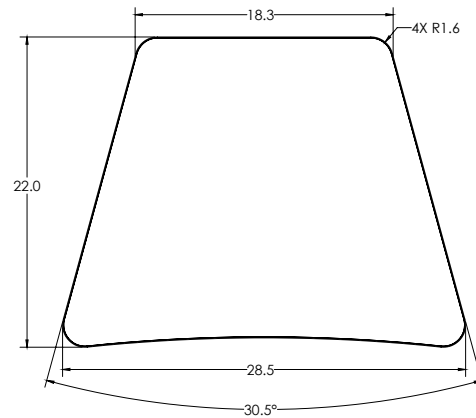
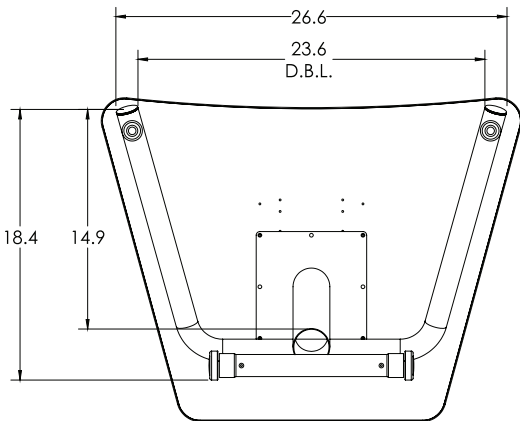
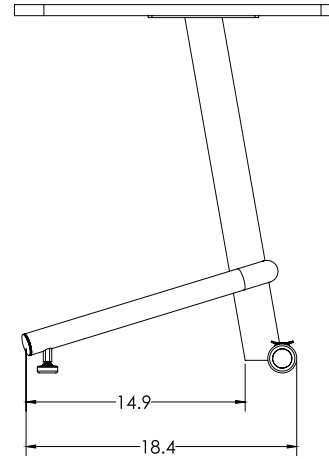
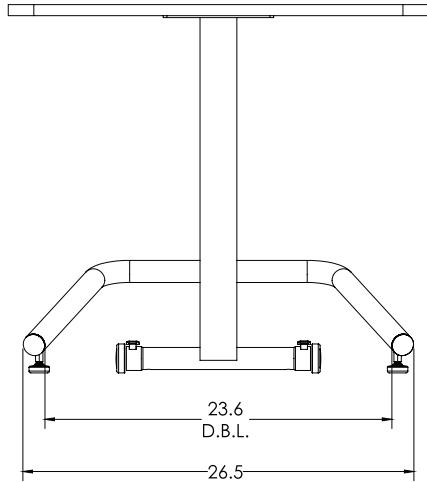

MODEL	FRAME WIDTH"	FRAME DEPTH"	TOP HEIGHT"	FLIPPED HEIGHT "	TOP WIDTH"	TOP DEPTH"
NF25-TZE	26.5"	18.6"	25.0"	25.0"	28.5"	22.0
NF27-TZE	26.5"	18.6"	27.0"	27.0"	28.5"	22.0
NF29-TZE	26.5"	18.6"	29.0"	29.0"	28.5"	22.0
NF36-TZE	26.5"	18.6"	36.0"	36.0"	28.5"	22.0
NF42-TZE	26.5"	18.6"	42.0"	42.0"	28.5"	22.0