

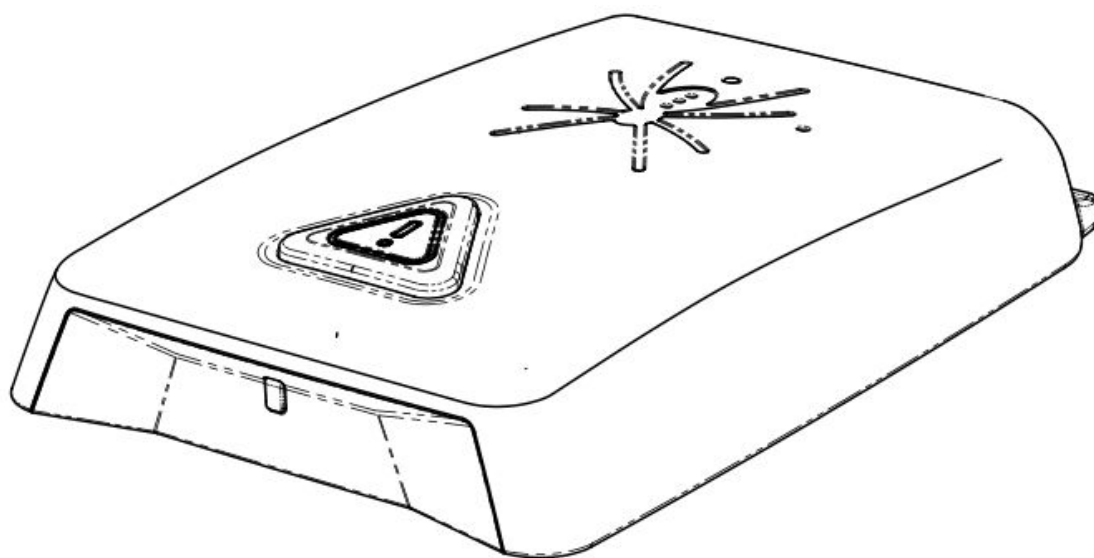

spidertracks



USER MANUAL

Spider X

Safety & Regulatory Information



Please read this guide carefully. It is important that all installation requirements are followed.

Installation must be completed by a suitably qualified person (check your local regulatory requirements).

Refer all servicing to Spidertracks qualified service personnel. Servicing is required when the apparatus has been damaged in any way. Changes or modifications not expressly approved by the party responsible for compliance could void the user's authority to operate the equipment.

This equipment has been tested and found to comply with the limits for a Class A digital device, pursuant to part 15 of the FCC Rules. These limits are designed to provide reasonable protection against harmful interference when the equipment is operated in a commercial environment.

This equipment generates, uses, and can radiate radio frequency energy and, if not installed and used in accordance with the instruction manual, may cause harmful interference to radio communications. Operation of this equipment in a residential area is likely to cause harmful interference in which case the user will be required to correct the interference at his own expense.

This equipment complies with FCC radiation exposure limits set forth for an uncontrolled environment and meets the FCC radio frequency (RF) Exposure Guidelines. This equipment should be installed and operated keeping the radiator at least 40cm or more away from the person's body.

Hereby, Spider Tracks Ltd declares that the radio equipment type Spider X (SKU 6000SX) is in compliance with Directive 2014/53/EU.

The full text of the EU declaration of conformity is available at the following internet address: spidertracks.com/compliance.

Contents



1. Getting Started	5
1.1 Overview	5
1.2 What's in the box?	6
2. Install	7
2.1 Activate	7
2.2 Locate	8
2.3 Mount	9
2.4 Power	9
3. Use	10
3.1 Operate	10
3.2 Connect a mobile device	11
4. Help	12
4.1 Contact	12
4.2 Warranty	13
4.3 Troubleshooting	14
4.4 Accessories & Spares	15
4.5 Disposal and Returns	16
5. Specifications	17

1 Getting Started



1.1 Overview

The Spider has the following key features:

- **Tracking** - Virtual FDR™ real-time tracking, using the Iridium global satellite network.
- **Messaging** - Use your mobile device to send or receive satellite Spidertxt messages.
- **Flight data** - Attitude data is automatically sent to the cloud when in cellular coverage.

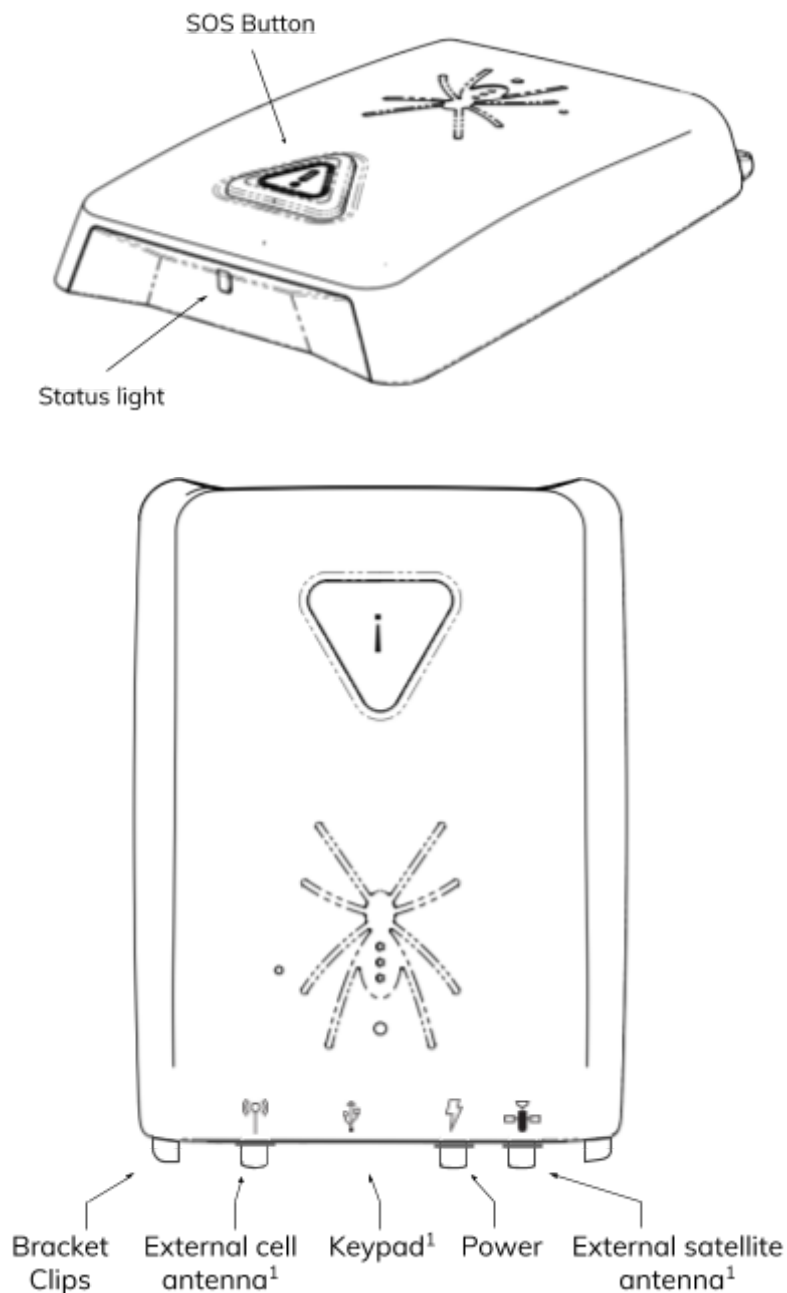

1. These connections are optional only and not required in a standard installation.



1.2 What's in the box?

The following items are included in the box:

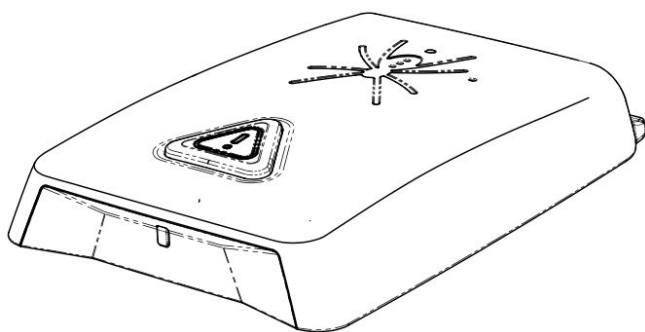

Spider X

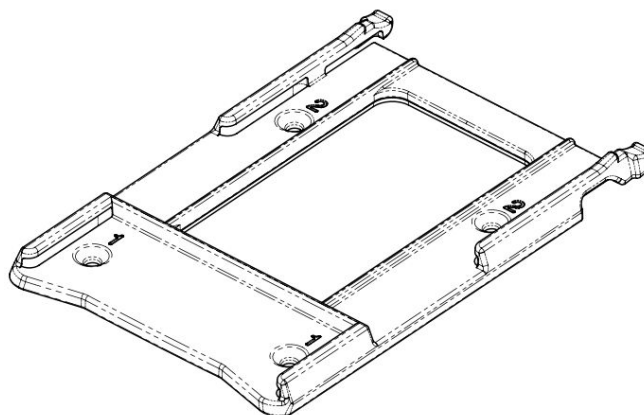

Bracket with adhesive

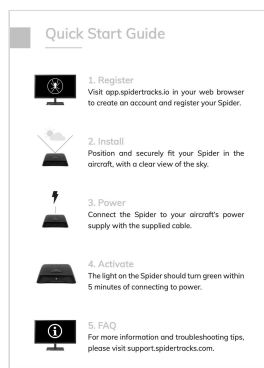

Quick start guide

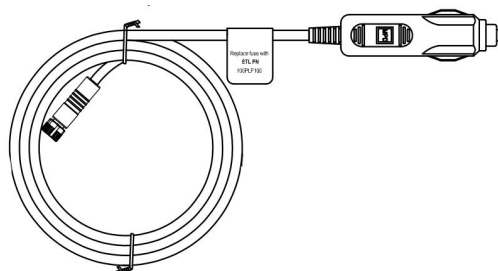

2m power lead

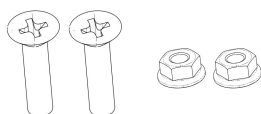

Polymer fasteners and flange nuts
Bag label #1

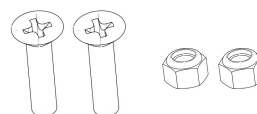

Stainless steel fasteners and nylock nuts
Bag label #2

2 Install



2.1 Activate

You need to activate your Spider before it can be used. Please refer to the step-by-step instructions available at support.spidertracks.com.

A. Create your account

Before you can activate your Spider you need to have created a user account, organisation and aircraft at app.spidertracks.io.

B. Register the device

Once your account has been created you need to register your device and assign it to an aircraft. For this step you need the 10-character serial number that is located on the base of the device.

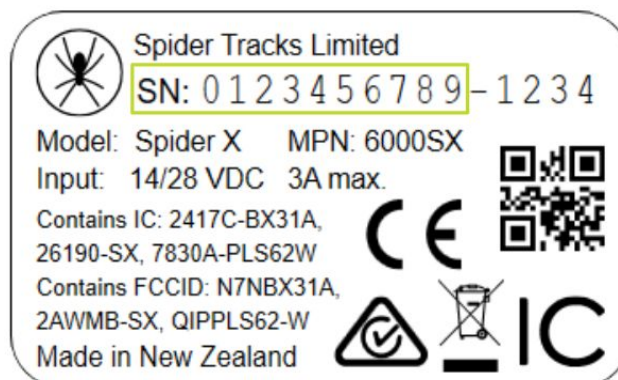

C. Confirm setup

To confirm the Spider setup you should power it with a clear view of the sky. If successful, the status light will illuminate green within 5 minutes. Check that the aircraft appears in your account.



2.2 Locate

You need to install the Spider with a clear view of the sky. In most aircraft, locating the Spider on top of the instrument panel provides an adequate view of the sky. It must be located greater than 300mm (11.8") from magnetic compasses or flux gates.

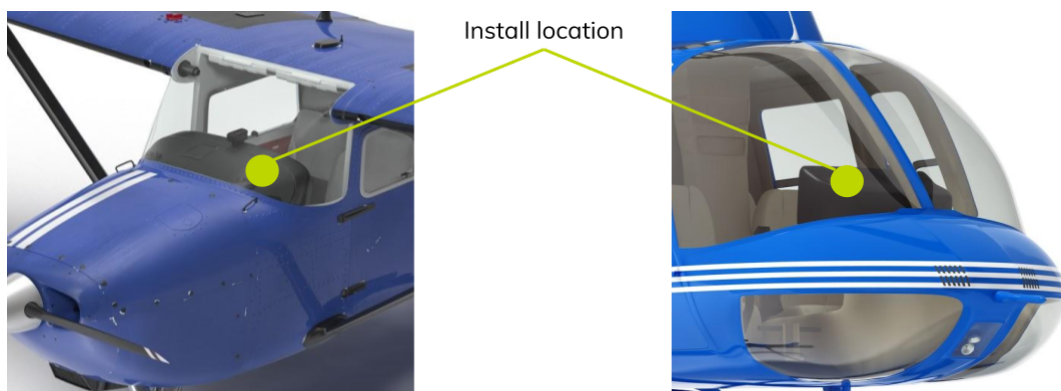

This location typically provides a good view of the sky with only minor obstructions, enabling a reliable connection to one or more Iridium satellites.

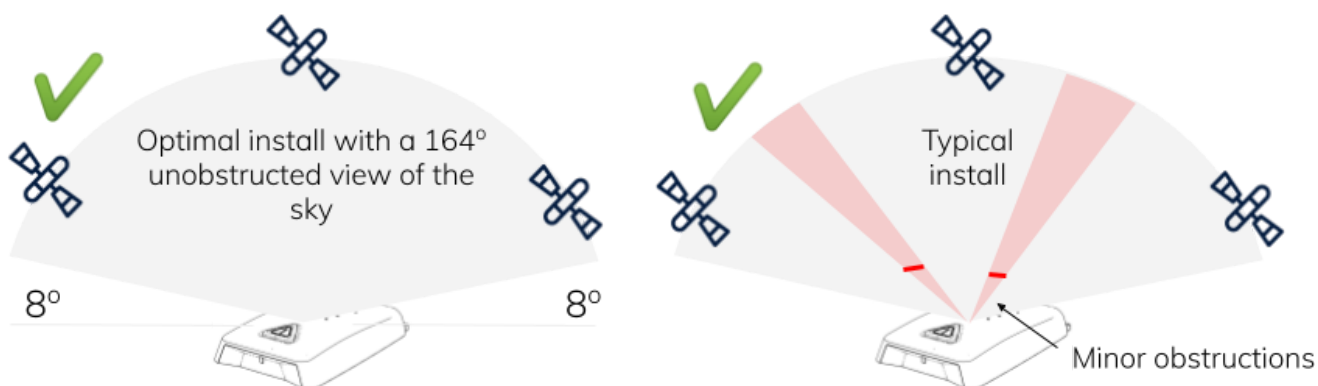

Some aircraft, such as those with heated windshields, can have significant obstructions made from metallic or carbon based materials. In this case you may need to utilise an [external Iridium/GPS antenna](#). Refer to [4.3 Troubleshooting](#).

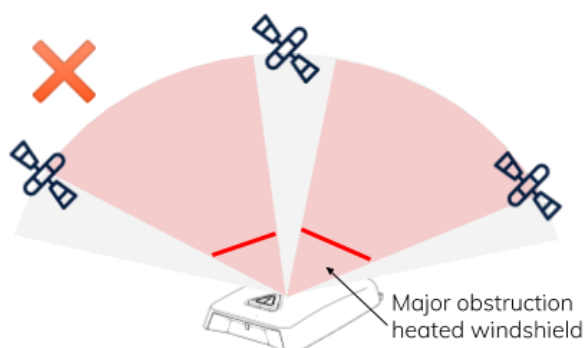



2.3 Mount

The Spider is supplied with a detachable mounting bracket. To remove the bracket; press down on the two rear tabs and slide the Spider forward. Choose one of the mounting options below.

Adhesive tape

- A. The adhesive tape can only be applied once.
- B. The surface under the bracket must be flat, dry and free of dust or oil.
- C. Remove the adhesive backing, place the bracket firmly in place, ensuring all sides have made firm contact with the surface.
- D. Final strength is achieved after 72 hours at 20 °C (68°F).

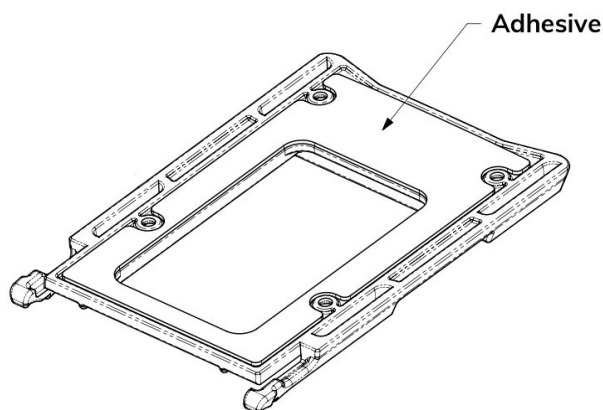

Fasteners

- A. The Spider is supplied with four M4 fasteners and nuts, 2 x polymer and 2 x stainless steel.
- B. The fasteners from the bag label #1 must be used in the two holes marked 1 on the bracket. Failure to do so could impact performance.
- C. The fasteners from the bag label #2 must be used in the two holes marked 2 on the bracket.

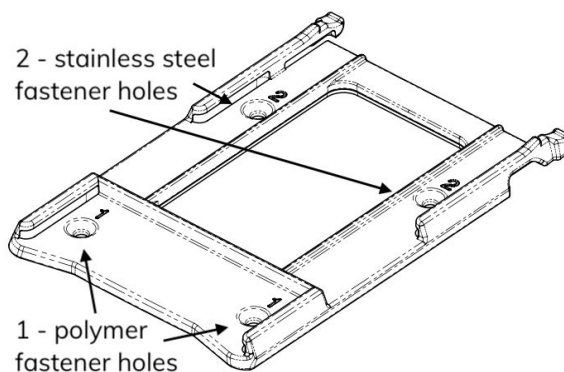

2.4 Power

The 2m (6' 6³/₄") power lead connects the Spider to a cigarette power outlet. Insert the mating cable connector into the Spider power input and screw finger tight.

For more details on the power requirements refer to [5. Specifications](#).

3 Use



3.1 Operate

When powered, the Spider will automatically connect, no interaction is required from the pilot or crew. In the event of an emergency the SOS button can be pressed. The light on the front indicates the status of the Spider as shown in the table below.

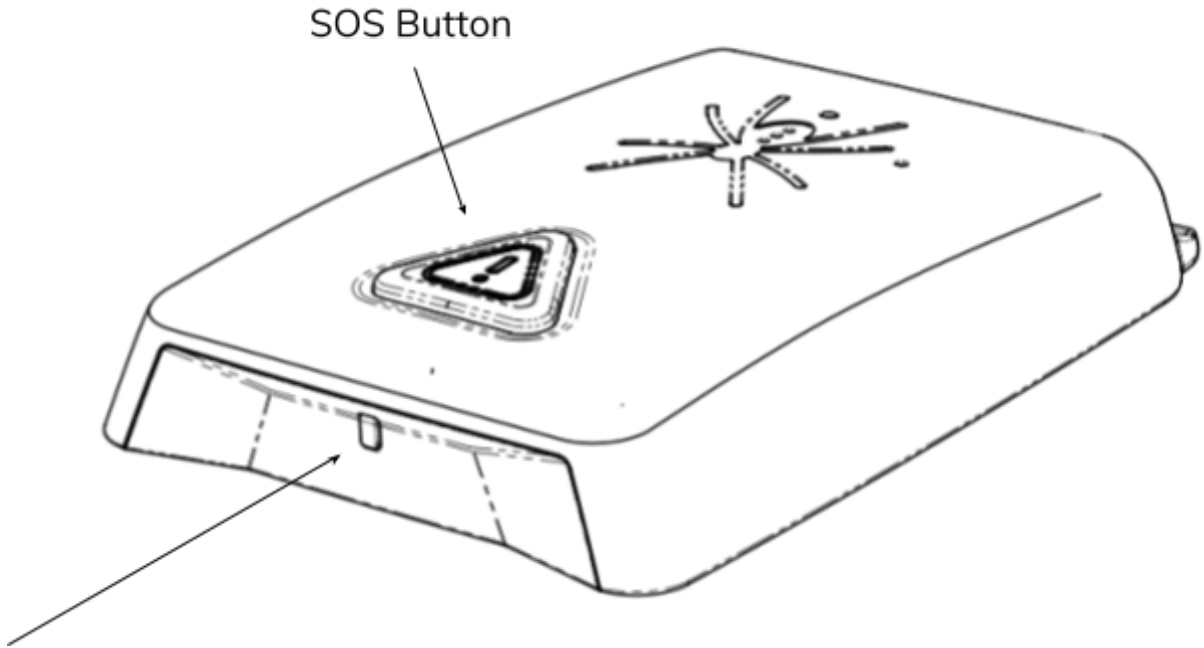

Light

Grey	Off	No power
Amber	Amber	No satellite connection. It can take up to 5 minutes to connect.
Green	Green	Satellite connection OK
Red	Red	SOS activated
Green	Green flashing	On backup power, connection OK
Red	Red flashing	On backup power, SOS activated
Amber	Amber flashing	On backup power, no satellite connection.
Red	Amber flashing	Self-test failure, see troubleshooting guide
Green	Red flashing	Software update in progress

Optional Spider settings can be configured through app.spidertracks.io. This includes notifications for SOS, speed threshold, heading change, rate of climb or rate of descent.



3.2 Connect a mobile device

The app enables you to wirelessly connect to the Spider. You need to install the Spidertracks app from either the Apple® App Store® or Android™ Google Play store.

The first time you use the app you will be prompted to login using the same email address and password for the account you created on the Spidertracks website.

To connect to the device select *More > Spider Connection*, then select your aircraft from the list of available Spiders. If you are unable to connect refer to [4.3 Troubleshooting](#).

Spidertxt



To use Spidertxt its needs to be enabled on your account.

- Anyone in your account can send and receive messages to other members of your account.
- Spidertxt prioritises using wifi, cellular data, then the Iridium satellite network.
- Messages sent over Iridium can take longer than messages sent over cell.
- See support.spidertracks.com for more information on the setup and use of Spidertxt.

4 Help



4.1 Contact

For service and support:

Support Documentation: <https://support.spidertracks.com>

Email: support@spidertracks.com

Phone:



Australia

+61 1800 461 776



Canada

+1 800 491 2895



Mexico

+52 55 4169 3149



New Zealand

+64 9 222 0016



South Africa

+27 87 550 3970



United Kingdom

+44 20033 31519



United States

+1 800 491 2895

Address:

Spidertracks
205/150 Karangahape Road
Auckland, 1010
New Zealand



4.2 Warranty

The Spider X comes with a 12 month warranty from date of purchase. You must [notify Spidertracks](#) as soon as a defect is discovered. If the device needs to be returned for repair, a return merchandise authorisation (RMA) will be issued. Spidertracks will replace your Spider with a new or refurbished Spider X. You are responsible for all return shipping costs of the device under RMA. Any attempt to repair or open the device, water damage, or physical damage beyond normal wear and tear will void the warranty.

Australia

Our goods and services come with guarantees that cannot be excluded under the Australian Consumer Law. For major failures with the service, you are entitled:

- to cancel your service contract with us; and
- to a refund for the unused portion, or to compensation for its reduced value.

You are also entitled to choose a refund or replacement for major failures with goods. If a failure with the goods or a service does not amount to a major failure, you are entitled to have the failure rectified in a reasonable time. If this is not done you are entitled to a refund for the goods and to cancel the contract for the service and obtain a refund of any unused portion. You are also entitled to be compensated for any other reasonably foreseeable loss or damage from a failure in the goods or service.



4.3 Troubleshooting

Symptom	Check
No power	<ul style="list-style-type: none">• Ensure power is connected.• Check power supply meets requirements per 5. Specifications• Check the fuse inside the cigarette lighter plug. If blown, a replacement fuse, PN: 100PLF100, can be ordered. Please consult Spidertracks for approval of alternative fuse options.
Power and green light status but no flight information on website	<ul style="list-style-type: none">• Ensure account registration and Spider activation steps have been completed• Ensure Spider has been assigned to an aircraft.
Partial flight information missing on website	<ul style="list-style-type: none">• Check the location of the Spider and follow guidance per 2.2 Locate. The Spider must have a clear view of the sky. Check there are no obstructions inside and outside the aircraft (e.g. tall buildings).• Ensure there is nothing covering the Spider during operation.• If the problem persists, contact support@spidertracks.com and request further analysis of the Spider performance.
3D flight replay issues	<ul style="list-style-type: none">• If mounting with fasteners, check supplied fasteners are located in the correct mounting holes on the bracket. Failure to do this can degrade performance.
Spider is signalling updating software	<ul style="list-style-type: none">• The device automatically downloads new software when in cell coverage to keep in sync with the features of the system. It will update the software on the next power cycle. It will not update when in flight. The Spider is ready for use again when the status light has returned to normal per 3.1 Operate.



4.4 Accessories & Spares

Name	Part number	Description
2m power lead	2000PWR602	Power cable 2m (6' 6 ³ / ₄ ")
Mounting bracket	3000BRK106	Bracket kit with fasteners
External satellite antenna	3000ANT107	Optional external Iridium/GPS antenna, supplied with 4m of cable. As default the Spider will use the internal antenna. You can switch to the external antenna using the mobile app.
Replacement fuse	100PLF100	Approved replacement fuse



4.5 Disposal and Returns

Spidertracks is committed to reducing waste.

EU

[Contact](#) our support team on how to return or dispose of your device.

The European Union (EU) has developed the WEEE (Waste Electrical and Electronic Equipment) Directive to ensure that systems for collection, treatment and recycling of electronic waste will be in place throughout the European Union.

This directive requires manufacturers of electrical and electronic equipment who sell into EU countries to encourage consumers of such equipment to appropriately recycle the equipment at the end of their lifespan.

Global

[Contact](#) our support team on how to return or dispose of your device.

5 Specifications



Part number	6000SX
Dimensions	150mm x 108mm x 32mm (5.91" x 4.25" x 1.26")
Weight	255g (9oz)

Wireless interfaces

Cellular	LTE: Ten Bands 1/2/3/4/5/7/8/12/20/28 UMTS/HSPA+ : Seven Bands 1/2/4/5/8/9/19 GSM/EDGE/GPRS: Quad band 850/900/1800/1900 MHz Embedded eSIM with global roaming ² SMA connector for optional external antenna.
Satellite	Iridium: Short Burst Data with global roaming ² GNSS: Galileo and GPS SMA connector for optional external antenna
Bluetooth	BLE v4.2

Physical Interfaces

USB	USB 2.0 - USB-C locking connector
M8 4-pin	Shares power and serial RS-232 or RS-485 half duplex

Power

Voltage	Class 1 energy source 14 VDC \pm 15% or 28 VDC \pm 15%
Consumption	2.8W nominal (3A. max)
Protection	Cable includes 3A normal (fast) blow fuse. Only use approved spare part.

Environmental

Operating temperature	-30°C to +60°C (-22°F to 140°F)
Storage temperature	-40°C to +85°C (-40°F to 185°F)
Operation and storage	Indoor, not water resistant

Regulatory

RTCA DO-160G, CE, FCC, IC, RCM, Iridium Certified, PTCRB

Specifications subject to change without notice.
Note 2: Not all regions are supported by global roaming.