

Technical Information

How the energy from a vehicle impact is calculated

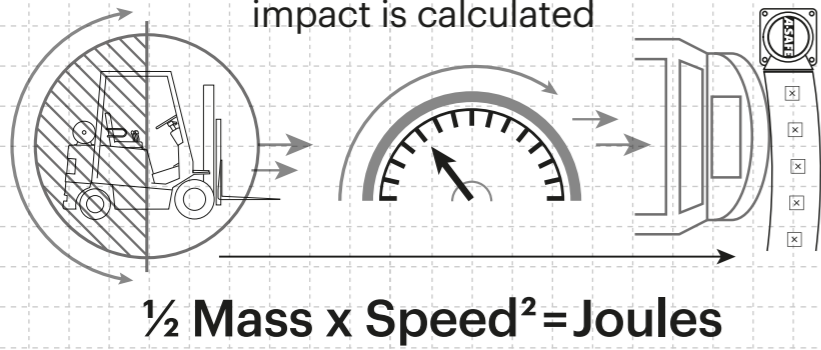

Tested Impact Energy
30,200 Joules
 Equivalent vehicle and speed

13.3 ton X **5 mph impact**

Mid Rail 45° Impact on 78 1/4 inch Post Centers

Impact Test	Impact Angle on 78 1/4 inch Post Centers			
	90°	67.5°	45°	22.5°
Mid Rail Max Energy (Joules)	15,100	17,691	30,200	103,109
End Post Max Energy (Joules) - 90°	6,900			

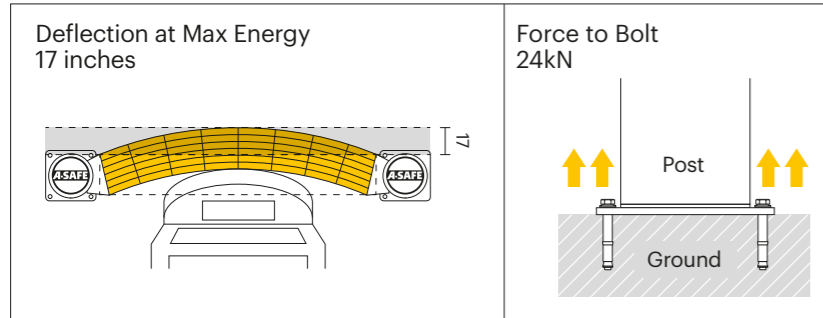

Material Properties	MEMAPLEX™
Temperature Range	14°F to 122°F
Ignition Temperature	698°F to 734°F
Flash Point	662°F to 698°F
Toxicity	Not Hazardous
Chemical Resistance	Excellent - ISO/TR 10358
Weathering Stability (Grey Scale)	5/5*
Light Stability (Blue Wool Scale)	7/8**
Static Rating (Surface Resistivity)	1015 - 1016 Ω
Hygiene Seals	Yes

* Weathering scale 1 is very poor and 5 is excellent
 ** Light stability scale 1 is very poor and 8 is excellent

Dimensions (inches)

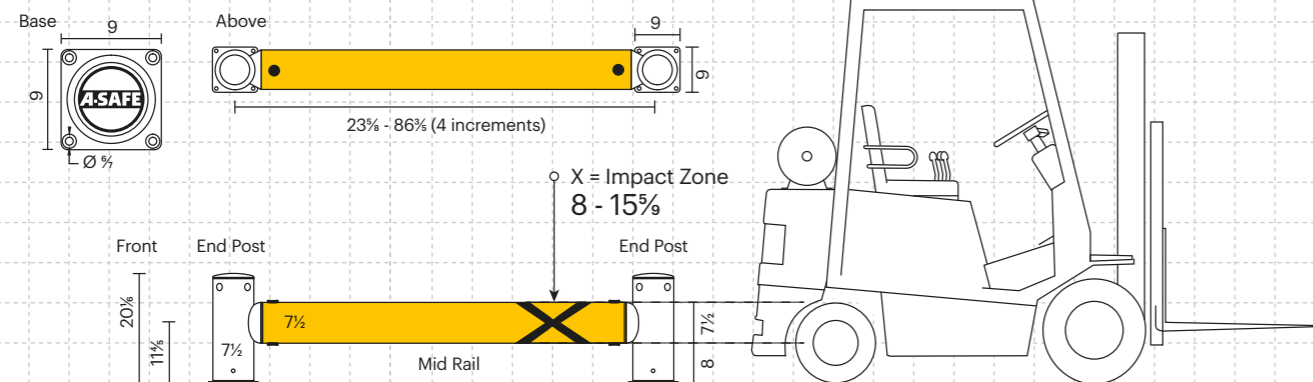

Post Options



Rail Options

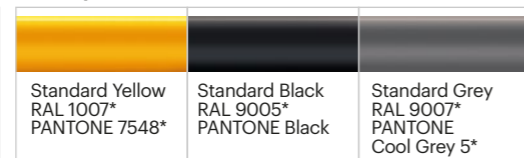

Color Combinations

*Please note that the RAL and PANTONE colors listed are the closest match to standard A-SAFE colors, but may not be exact matches of the actual product color and should be used for guidance only.



iFlex™

Single RackEnd Guardrail



Designed to protect the end of racking aisles where turning vehicles and equipment can impact vulnerable racking structures.

This RackEnd guardrail provides heavy duty protection to shield racking systems from high impact accidents and prevent damage.

The circular end posts provide enhanced protection at the guardrail ends which are most susceptible to impact. Innovative spinning collars further deflect and dissipate impact forces.



Tested to the global benchmark in guardrail safety

bsi. PAS 13
 Code of Practice for Workplace Safety Guardrails

Testing Criteria to determine essential Product Properties of Collision Protection Systems:

- PAS 13, Sec. 7.7 (Sled and Ramp Impact test)
- PAS 13, Sec. 7.8 (Pass and Fail Criteria)

For further information: www.tuv-nord.de



Your Authorized A-Safe Distributor
 856-687-2227 • jason@banksindustrial.com • www.banksindustrial.com
 PO Box 382 • Berlin, NJ 08009

Engineered for performance

Whether in the resilience, flexibility and in-built memory of our exclusive Memaplex™ material or the unrivalled energy absorption of our unique 3-phase coupling system, a wealth of technical ingenuity goes into every A-SAFE product to ensure that it performs perfectly every time you need it to. We are continuously innovating to solve the greatest workplace safety challenges on behalf of our customers and our numerous patents attest to our industry-leading commitment to research and development.

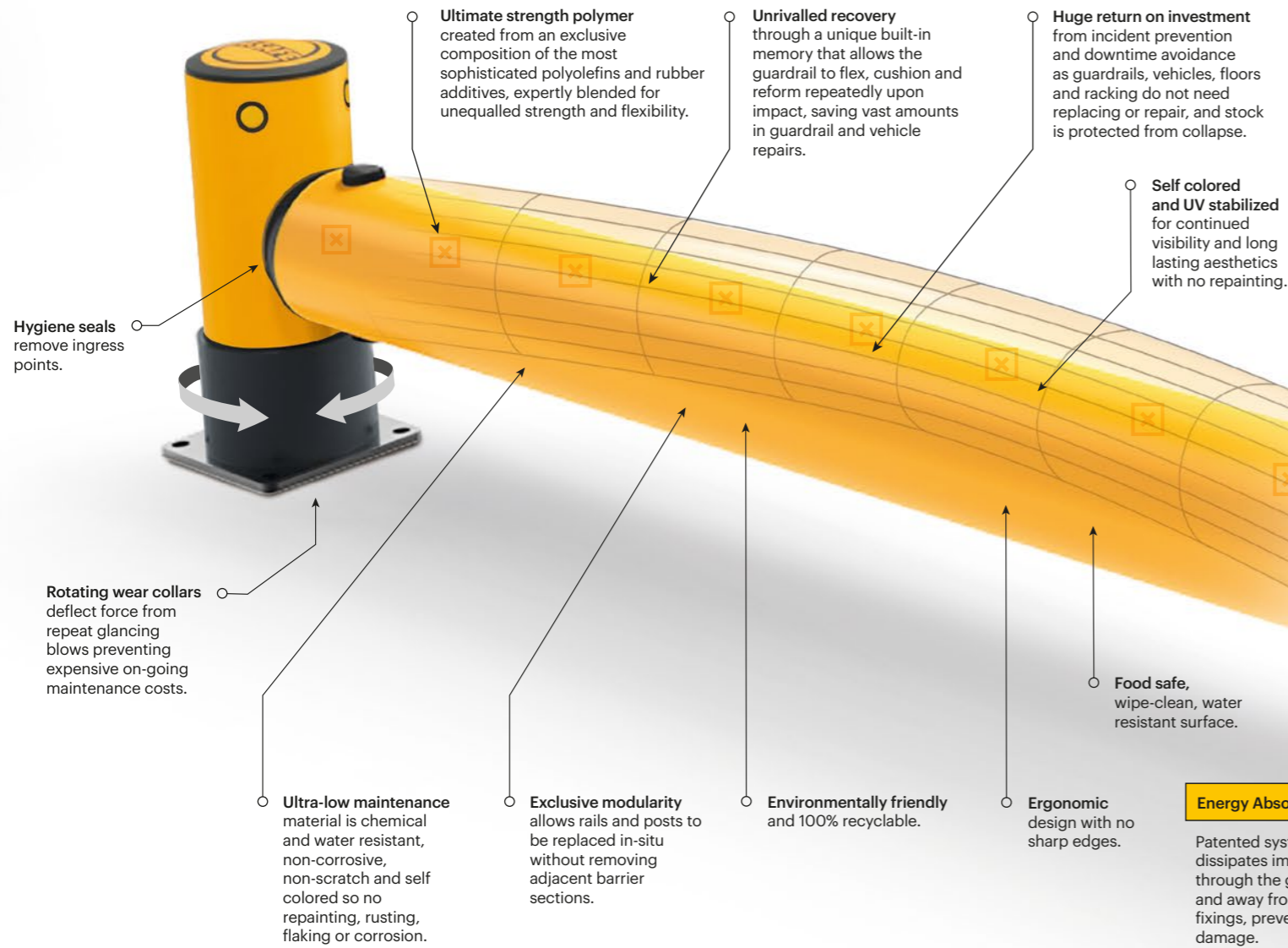

iFlex RackEnd Barrier shown with optional iFlex ForkGuard.

MEMAPLEX™

Advanced Engineering
Molecular reorientation during manufacturing creates a unique built-in memory that enables the barrier to fully recover following impacts.

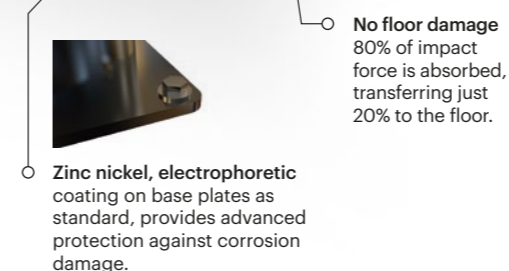
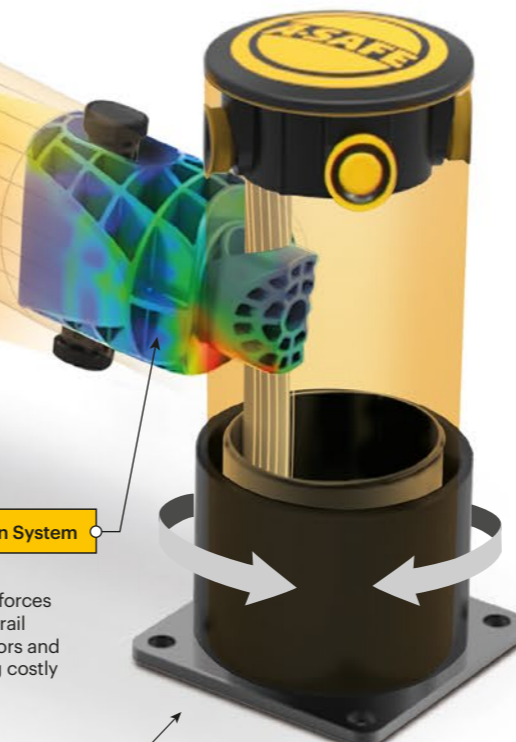
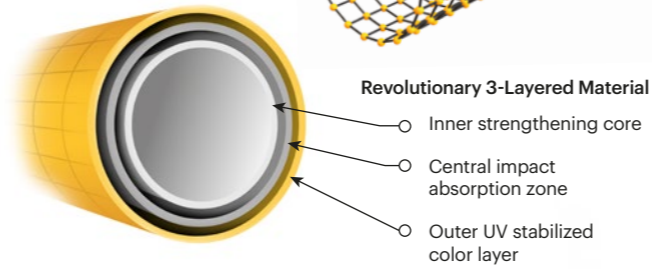

ADDITIONAL BASE OPTIONS

Countersunk Bolts	Galvanized Steel	Stainless Steel 316 Standard	Stainless Steel 316 Countersunk
Creates a flat surface, preventing tyre damage where vehicles are in close proximity.	Increased weather resistance for outdoor use and harsh climate environments.	Ultimate performance option, no corrosion or rusting and resistant to powerful cleaning agents. Ideal for hygiene environments.	

Energy Absorption System

A patented 3-phase system that activates sequentially for unparalleled energy absorption

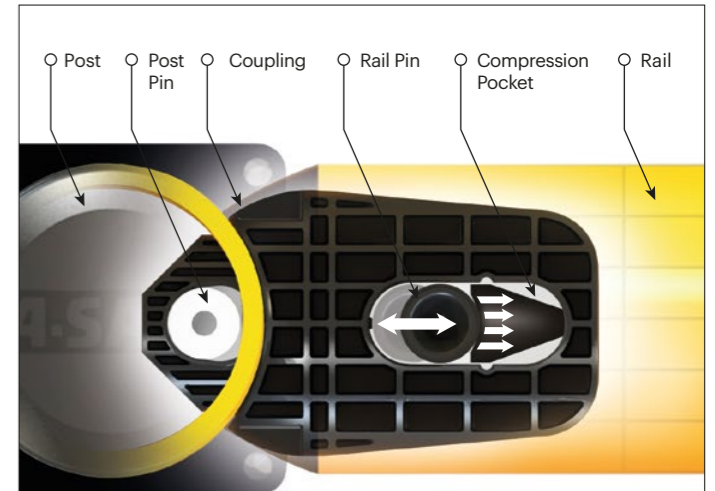

PHASE 1: Memaplex™ rail flexes to absorb impact, initiating the rail pin to slide forward and transfer load energy to the compression pocket.

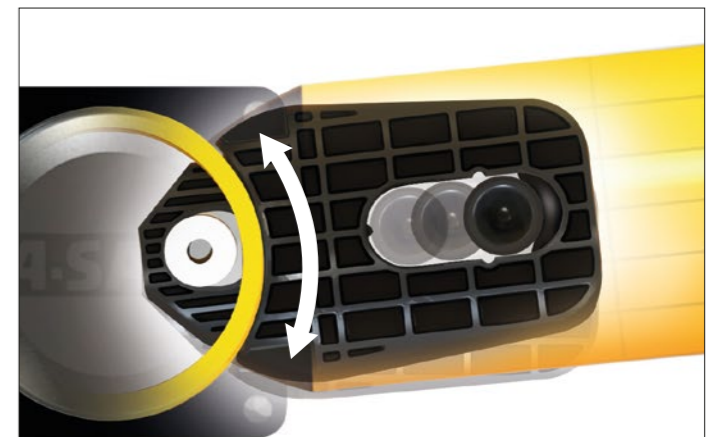

PHASE 2: Compression of the pocket continues to disperse energy as the coupling rotates around the post pin to activate further absorption.



PHASE 3: At peak energy, the coupling twists further, engaging the post pin and instigating torsion of the post to dispel remaining forces.