

Extraction Technology-Water
**Continuous Cold Water
Refining Equipment**

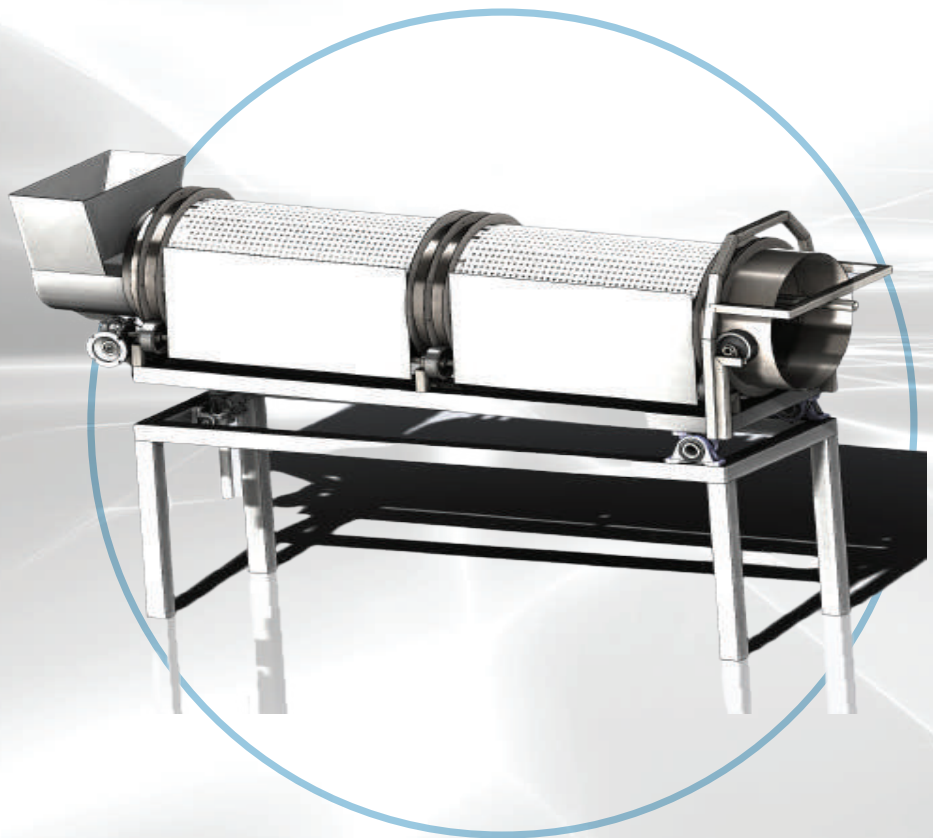

POSEIDON

Water Refining Equipment



Starting from
100-200 lbs per hour



Fully Continuous
Bulk Trichome
Separation



Automatic UltraVibe
Filtration



Automatic Spent
Biomass Rejection

maratek.com

est. 1967

Poseidon Cold Water Trichome Refining

100-200 lbs per hour

304 Stainless Steel Construction

Automatic UltraVibe Filtration

Closed Loop Water Chilling

Pitch Controlling

Key Equipment Features:

- Up to 80% biomass reduction through Trichome Refinement
- No liquid nitrogen required
- Automatic Filtration from 200 to 25 microns
- Optimized for fresh or dried biomass
- Low cost of operation
- Increase your ethanol efficiency
- Automatic biomass handling
- 100-200+ pound per hour processing
- 304 stainless steel on all product contacting surfaces
- Integrated internal mixing paddles with optional agitation balls

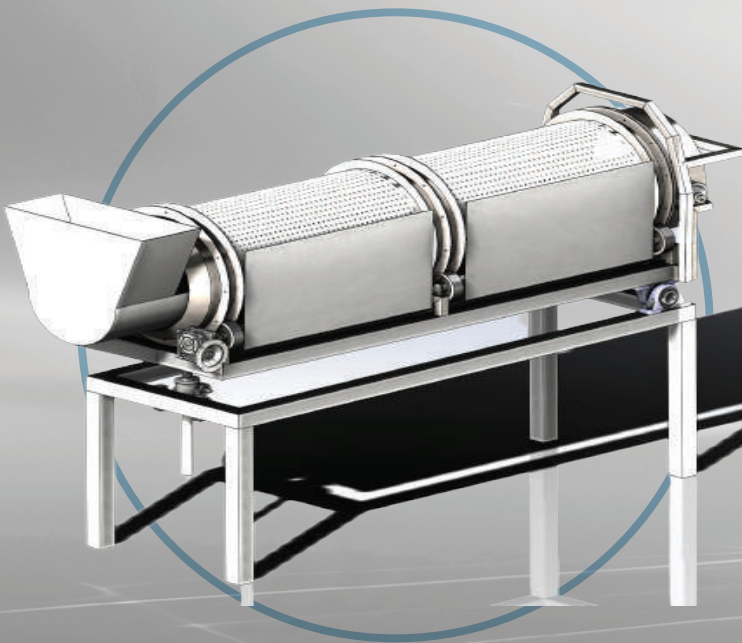

Contact

References available upon request with installation in facilities across the US, Canada and globally. Contact us now for a quote on our extraction equipment!

Call: 905.857.2738 | Toll Free: 1.800.667.6272 | Email: sales@maratek.com | www.maratek.com

Canada
39 Nixon Road
Bolton, Ontario,
Canada,
L7E 1K1

USA
250 Monroe Ave
NW, Suite 400
Grand Rapids, MI
49503

Mexico
Fuente Bella 3299,
Ciudad de Mexico,
14130,
Mexico

maratek
Automate | Optimize | Scale