

SPECIFICATIONS - PART NO. BIG-750-O

- 4" inlet/outlet Sch. 40 (No-Hub)
- Max flow rate: 75 GPM / Liquid capacity: 140 Gallons
- Max Liquid capacity: 750 lbs. (105 Gallons)
- Max solids/sediment capacity: 105 Gallons
- Unit weight w/std. covers: 150 lbs.
- H-20, 20,000 lb. load rated, bolted, gas/water tight composite covers.
- Maximum operating temperature 190° F continuous.
- Made from rotationally molded High Density Polypropylene (HDPE)
- Made in USA / Limited Lifetime Warranty / Both indoor and outdoor use



"The Big Max was delivered on time and on specification. The use of the generic corrugated extensions made installation easy and extremely efficient.."

– Avcon Construction, North York, Ontario, Canada

Suffix	Optional Variations	Model No.
-AK	Anchor kit (set of four) - for 75 GPM HDPE int.	BIG-750-AK-SET
-AK	Anchor kit (set of four) - for 100 GPM HDPE int.	BIG-1150-AK-SET
-C	Lid extension (specify "C" dimension req.) - for 75 GPM (This is up to a 44" high extension system)	BIG-EXT-44
-C	Lid extension (specify "C" dimension req.) - for 100 GPM (This is up to a 44" high extension system)	BIG-EXT-44 (2 pcs req.)
-C+	Lid extension from 44" to 72" (specify "C" dimension req.) For 75 GPM HDPE Interceptors. Per inch price.	BIG-EXT-72
-C+	Lid extension from 44" to 72" (specify "C" dimension req.) For 100 GPM HDPE Interceptors. Per inch price.	BIG-EXT-72 (2 pcs req.)
-COA	Coalescer Pack	BIG-COA
-DI	Ductile Iron lid and collar - for 75 GPM HDPE Int.	BIG-PL4
-DI	Ductile Iron lid and collar - for 100 GPM HDPE Int.	BIG-PL4 (2 pcs req.)
-EP	Enzyme port	BIG-EP
-F6	6" no hub inlet + outlet-(for each piece-2 pcs req. per int.)	BIG-PF6
-FL-C	Membrane clamp kit	BIG-FLC
-HLA	High level alarm and float switch (to be installed on site)	BIG-HLA
-HT	Holding Tank	
-LHSI	4" no hub inlet on left hand side	BIG-PF4
-LHSO	4" no hub outlet on left hand side	BIG-PF4
-POK	Remote pump out kit	BIG-POK
-RHSI	4" no hub inlet on right hand side	BIG-PF4
-RHSO	4" no hub outlet on right hand side	BIG-PF4
-RPO	4" Remote pump outlet connections on top of interceptor - specify location and number required	BIG-RPO
-SB	Sediment bucket for 75 GPM HDPE Int.	BIG-750-PSB
-SB	Sediment bucket for 100 GPM HDPE Int.	BIG-1150-PSB
-SP	External Sampling port - inline, high connections	BIG-SP
-SP-L	External Sampling port - inline, low connections	BIG-SP-L
-SP-OFF	External Sampling port - offset	BIG-SP-OFF
-T	Female threaded connections (for each piece-2 pcs req. per int.)	BIG-PF(*)-FT(*) (*) Specify Conn. Size

BIG-750-O HDPE Oil Interceptor

U.S. Patent
9,551,142

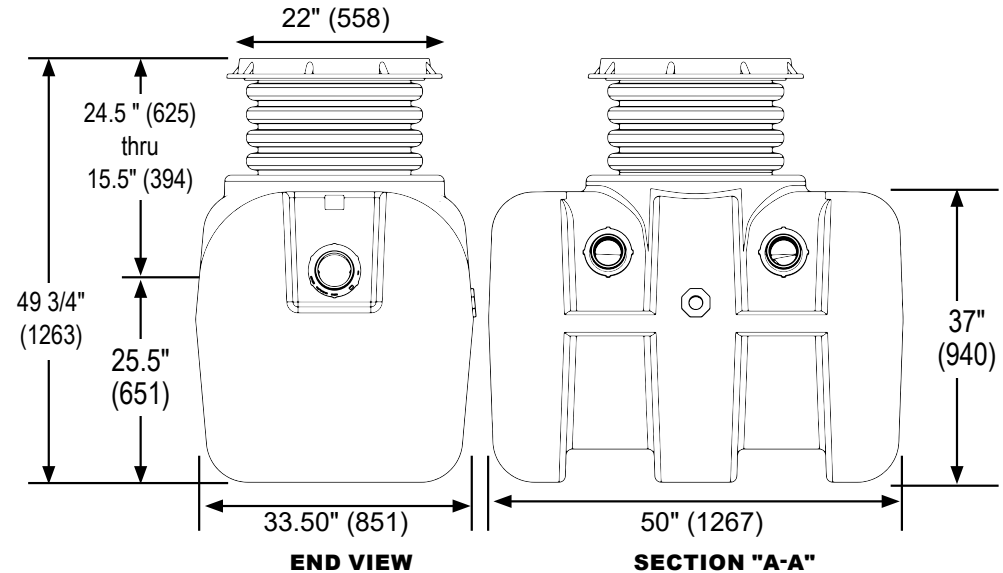

*Note: The BIG-750 does not meet PDI standard if outfitted with the use of an internal flow control (-OP suffix). The PDI standard is only valid with the use of an external flow control fitting.

SIGNATURE OF APPROVAL: _____

COMPANY: _____

DATE OF APPROVAL: _____

SERIES PART NUMBER: BIG (OIL)

DESCRIPTION:
 MIFAB® Big Max Series high density polyethylene (H.D.P.E.) oil interceptor.
 Available Sizes: 75 GPM (BIG-750-O) and 100 GPM (BIG-1150-O)



MIFAB, Inc. 1321 West 119th Street, Chicago, Illinois 60643-5109, USA
 Toll Free 1-800-465-2736 • Fax 1-773-341-3049
 www.mifab.com • sales@mifab.com • Canada Toll Free: 1-800-387-3880



The BIG-750-O is tested and certified to the following standards:
 PDI-G-101, ASME A112.14.3, CSA B481.1 and is listed with IAPMO.