

SPECIFICATIONS (GI-SS-500)

- 4" inlet/outlet (No-Hub)
- Liquid capacity: 500 U.S. Gallons 1,890 Litres
- Grease Retention Capacity at Flow Rate of 100 GPM: 3,492 lbs. (485 Gallons)
- Grease Retention Capacity at Flow Rate of 250 GPM: 1,916 lbs. (266 Gallons)
- Unit weight with standard covers: 950 lbs.
- Made from rotationally molded High Density Polypropylene (HDPE)
- Made in USA / Limited Lifetime Warranty / Both indoor and outdoor use

NOTE: PDI tested at 100 GPM



**CERTIFIED
MANAGEMENT SYSTEM
- ISO 9001:2015**

T&C

TOWN & COUNTRY PLASTICS

Customized For Precision

Suffix	Optional Variations
-AK	Anchor kit (set of two)
-C	Lid extension (specify dimension required)
-COA	Coalescer Pack
-DI	Ductile iron lid & collar
-DP	Dosing pump
-EP	Enzyme port
-FL-C	Membrane clamp kit
-F6	6" No Hub Inlet / Outlet connection (flow rate of 700 GPM with 6" connections)
-F8	8" No Hub Inlet / Outlet connection (fabricated stainless steel) (flow rate of 1,200 GPM with 8" connections)
-HLA	High level alarm and float switch (to be installed on site)
-LHSI	4" no hub inlet on left hand side
-LHSO	4" no hub outlet on left hand side
-POK	Remote pump out kit
-RHSI	4" no hub inlet on right hand side
-RHSO	4" no hub outlet on right hand side
-RPO	4" Remote pump outlet connections on top of interceptor - specify location and number required
-SB	Sediment bucket
-SP	External Sampling port - inline, high connections
-SP-L	External Sampling port - inline, low connections
-SP-OFF	External Sampling port - offset
-V	Vent connection - 4" (specify number required and location - side and / or top)

GI-SS-500 Gravity Grease Interceptor

U.S. Patent
9,551,142

T&C

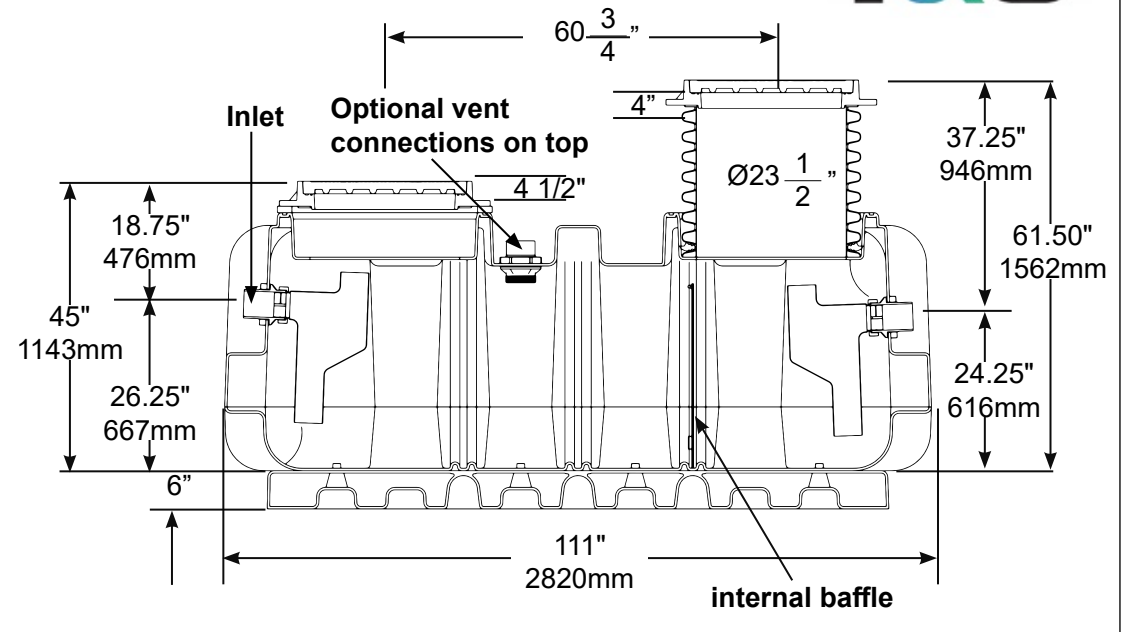

At 100 GPM

The GI-SS-500 is tested and certified to the following standards: PDI-G-101, ASME A112.14.3, CSA B481.1 and is listed with IAPMO.

SIGNATURE OF APPROVAL: _____

COMPANY: _____

DATE OF APPROVAL: _____

SERIES PART NUMBER: SUPER (GREASE)

DESCRIPTION: MIFAB® SUPERMAX Series high density polyethylene (H.D.P.E.) grease interceptor.

Other sizes: 750, 1000, 1250, 1300, 1500, 2000 (liquid holding capacity - gallons) Not tested to PDI standards.



MIFAB, Inc. 1321 West 119th Street, Chicago, Illinois 60643-5109, USA
Toll Free 1-800-465-2736 • Fax 1-773-341-3049
www.mifab.com • sales@mifab.com • Canada Toll Free: 1-800-387-3880