



# SOLID FUEL/WOOD HEAT SUPPLEMENT CHECKLIST

Date: \_\_\_\_\_

Insured Name: \_\_\_\_\_ Policy #: \_\_\_\_\_

## STOVE INFORMATION

Make & Model of stove: \_\_\_\_\_

Stove Location: \_\_\_\_\_

Type of unit:

- Wood Stove
- Inside Wood Furnace
- Fireplace Insert
- Outside Wood Furnace - Feet from Structure \_\_\_\_\_ ft.
- Pellet Stove

Installed by:

- Owner
- Contractor (if so, provide name) \_\_\_\_\_

What type of base material is under the stove: \_\_\_\_\_

Wall construction nearest the stove is: \_\_\_\_\_

Type of chimney:

- Metal List Type: \_\_\_\_\_
- Masonry List Lining: \_\_\_\_\_

What is the distance from the back of the stove to the wall: \_\_\_\_\_

What is the distance vertically from the stove pipe to the ceiling: \_\_\_\_\_

How far does the non-combustible floor covering extend:

Front of the stove \_\_\_\_\_ ft. Behind the stove: \_\_\_\_\_ ft. Each side of the stove: \_\_\_\_\_ ft.

What type of thimble protection where stove pipe passes through walls? \_\_\_\_\_

Is this the only stove (or furnace) vented into this chimney? \_\_\_\_\_

Does the top of the chimney extend above the roof line? \_\_\_\_\_ How far? \_\_\_\_\_ ft.

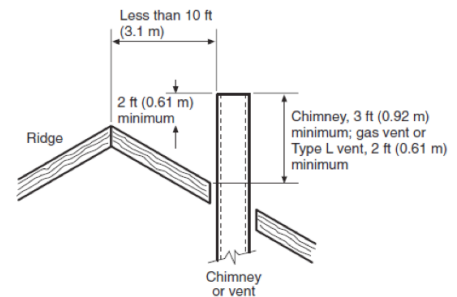
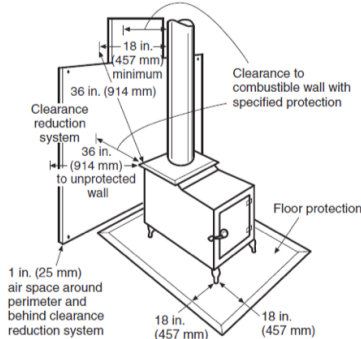

Agent Signature \_\_\_\_\_

Date \_\_\_\_\_